



**Rockwell  
International**

## **Collins instruction book**

*Part 1*

---

# **HF-8014( ) Exciter**

---

*Part 1 of this instruction book includes:*

<i>Description</i>	<i>523-0770719</i>
<i>HF-8014 Supplement</i>	<i>523-0770720</i>
<i>HF-8014A Supplement</i>	<i>523-0770721</i>
<i>Installation</i>	<i>523-0770722</i>
<i>Operation</i>	<i>523-0770723</i>
<i>Theory</i>	<i>523-0770724</i>
<i>Maintenance</i>	<i>523-0770725</i>
<i>Parts List</i>	<i>523-0770726</i>
<i>Diagrams</i>	<i>523-0770727</i>

---

**Collins Telecommunications  
Products Division  
Electronic Systems Group  
Rockwell International  
Cedar Rapids, Iowa 52406**

---

**Caution**

The material in this manual is subject to change. Before attempting any maintenance operation on the equipment covered in this manual, verify that you have a complete and up-to-date publication applicable to your equipment.

Please be advised that completion of the enclosed Automatic Distribution Service Card and return to Rockwell International ensures you of manual revisions and service bulletin modifications to your equipment. Without the return of this card, Rockwell International bears no responsibility to forward this information to you.

---

We welcome your comments concerning this instruction book. Although every effort has been made to keep it free of errors, some may occur. When reporting a specific problem, please describe it briefly and include the instruction book part number, the paragraph or figure number, and the page number.

Send your comments to: Logistics  
Collins Telecommunications  
Products Division  
Rockwell International  
Cedar Rapids, Iowa 52406

ATTN: Quality Control-Support Engineering 179-200

---

ADDENDUM 1

TO

HF-8014( ) EXCITER INSTRUCTION BOOK

(523-0770718-00121A)

Attached is a schematic diagram of Power Supply, part number 635-9649-001. Insert this schematic diagram as the last page of Power Supply (635-9649-001) Instructions, part number 523-0767948-202211.

Make the following additional corrections:

1. Description section, part number 523-0770719.  
Table 1, page 3. In the maintenance kit, change the part number for the 2-A fuse to 264-0305-000 and for the 1-A fuse to 264-4280-000.
2. Operation section, part number 523-0770723.  
Nonfunctional character #3 chart, page 21. Change the bits as shown.

NONFUNCTIONAL CHARACTER #3						
b <sup>7</sup>	b <sup>6</sup>	b <sup>5</sup>	b <sup>4</sup>	b <sup>3</sup>	b <sup>2</sup>	b <sup>1</sup>
1	0	1	1	0	0	0

3. Theory section, part number 523-0770724.  
Figure 12, page 55/56. In the LED Status Display, correct the light-emitting diodes to agree with the schematic diagram.

ADDENDUM 2

TO

HF-8014( ) EXCITER INSTRUCTION BOOK

(523-0770718-00121A)

GENERAL

The purpose of this addendum is to provide corrections to the HF-8014( ) Exciter Instruction book.

MAINTENANCE SECTION (dated 1 January 1981)

Make the following pen and ink corrections in the maintenance section.

Page 23, Test 8, step c, PROCEDURE column, add to step c:

"Adjust the output level of the 2-tone generator to cause the exciter meter to indicate compression (black segment of meter)."

Page 24, Test 8, Table, change DISTORTION LIMITS table as shown:

FROM		TO	
THIRD ORDER	CARRIER SUPPRESSION	THIRD ORDER	CARRIER SUPPRESSION
-50 dB mW max	-55 dB mW max	-50 dB max	-55 dB max
-50 dB mW max		-50 dB max	
-50 dB mW max	-55 dB mW max	-50 dB max	-55 dB max
-50 dB mW max		-50 dB max	
-50 dB mW max	-55 dB mW max	-50 dB max	-55 dB max
-50 dB mW max	-55 dB mW max	-50 dB max	-55 dB max

Page 24, Test 8, step i, PROCEDURE column.

change "... by 3 dB mW by adjustment"  
to read "... by 3 dB by adjustment"

Page 24, Test 8, step i, NORMAL INDICATION column.

change "Distortion is -50 dB mW max."  
to read "Distortion is -50 dB max."



# introduction

## DESIGN FEATURES

The HF-8014/8014A Exciter is a 4-channel ISB hf exciter that features flexibility, low-cost design, and high performance characteristics. The exciter has a frequency range of 1.6 to 29.9999 MHz tunable in 100-Hz steps over its entire range. It is capable of operating in the following modes of operation: AM (A3H), CW (A0, A1), A3A (reinserted pilot carrier), and ISB (A3B, A3J, A9B, A7J). In the ISB mode, each of the four channels (LLSB, LSB, USB, and UUSB) is enabled separately.

- The HF-8014/8014A Exciter makes an excellent manually controlled exciter for either a transmit-only site or a full communications station.

- The HF-8014A Exciter makes an excellent remotely controlled exciter and, using an HF-8093 Exciter Control, it can be remotely controlled up to 8 km (5 mi) over field wire or for unlimited distances over standard telephone circuits or radio links.
- Multiple HF-8014A Exciter installations can be controlled from one HF-8093 Exciter Control or one processor.
- The HF-8014/8014A Exciter is very flexible and is available with many options. Some of these options are strictly plug-in card changes/additions that can be accomplished easily by the customer or field technician. Other options require wiring and



HF-8014( ) Exciter

front panel modifications that require factory or service center changes. Some available options are as follows:

Oven standard: added to provide an accurate temperature-stabilized frequency.

1-Hz or 10-Hz tuning: added to meet a specific customer requirement.

Frequency display: provides solid-state display of selected operating frequency.

External frequency standard: used with a 100-kHz, 1-MHz, or 5-MHz external frequency standard.

- The HF-8014/8014A Exciter makes an excellent building block for an expanding system with no changes required to the exciter when expanding from a single exciter to a multiple exciter station and/or a complete duplex system. All system interconnections are made from the rear of the exciter and all local controls are on the front panel.
- The HF-8014/8014A Exciter is designed for ease of maintenance with front panel fault indicators and a meter to monitor specific outputs. Faults can be isolated and the unit can be placed on-line with a minimum downtime using plug-in circuit cards and modules.
- The HF-8014/8014A Exciter can be rack-mounted in a standard 483-mm (19-in) rack or in a small desk-top cabinet. Provisions are made for optional slide mounting in rack/cabinet installations.

## INSTRUCTION BOOK

This instruction book is divided into two parts.

Part 1 includes all instructions on the basic unit and supports repair of the basic unit to card/module replacement and/or replacement of components at the unit level.

Part 2 includes card, module, and options instructions sheets necessary to support repair to component parts of the cards and modules.

## SERVICE BULLETINS/SERVICE INFORMATION LETTERS

The following listed service bulletins (SB) and service information letters (SIL) are those that are applicable to the HF-8014( ) Exciter and are included in the text of this instruction book. Other applicable SB/SIL released before the instruction book was shipped are included in the front of the instruction book.

### Note

Service bulletins/service information letters are written in numerical sequence against the whole HF-80 family; therefore, all SB/SIL numbers are not included in the listing. Service bulletins are numbered in sequence for the life of the equipment. Service information letters are numbered in sequence starting at 1 for each calendar year.

<u>SB/ SIL</u>	<u>DESCRIPTION</u>	<u>ISSUE DATE</u>
--------------------	--------------------	-----------------------

# HF-8014( ) Exciter



Rockwell  
International

**description**

Collins Telecommunications Products Division

523-0770719-001218

1 January 1981

Printed in USA

## table of contents

<i>Paragraph</i>	<i>Page</i>
1. <i>General</i> .....	1
2. <i>Equipment Supplied/Configuration</i> .....	1
3. <i>Associated Equipment</i> .....	1
4. <i>Accessories</i> .....	6
5. <i>Options</i> .....	6
6. <i>Equipment Specifications</i> .....	6

Description

HF-8014( ) Exciter

523-0770719-001218



Table 1. Equipment Supplied/Configuration (Cont).

SUBASSEMBLY/CIRCUIT CARD		EXCITER		DESCRIPTION/FUNCTION
TITLE	PART NUMBER	HF-8014 622-3472-001	HF-8014A 622-3473-001	
Serial interface A13	638-6896-001		X	Can be switched for 7-bit ASCII or 8-bit character data format.  Can be switched for various serial controls: FSK; EIA RS-232C (CCITT V.24); or MIL-STD-188C.  Can be switched for various baud rates: 75, 109, 150, 300, 600, 1200, 2400, 4800, 9600, or 19 200 bauds.
Synthesizer voltage regulator A14	635-0656-001	X	X	
Synthesizer subcarrier generator A15	638-6962-001	X	X	
Synthesizer reference A16	642-2451-001	X	X	Can be strapped for an internal (INT) or external (EXT) frequency standard. If strapped EXT, external phase lock must be installed.
External phase lock A16A4	635-0655-001		X	Can be strapped for 100-kHz, 1-MHz, or 5-MHz external frequency standard. Part of AC-8012 Oven Standard Kit (622-3460-001) and AC-8013 External Standard Kit (622-3461-001).
Synthesizer end decade	635-0657-001	X	X	Installed as A19 provides 100-Hz tuning. Installed as A18 provides 10-Hz tuning. With appropriate decades added, installed as A17 provides 1-Hz tuning.
Synthesizer 100/10-Hz	623-2080-004			Not installed for 100-Hz tuning. Installed as A19 for 10-Hz tuning. Two installed, one as A19 and one as A18, for 1-Hz tuning. Part of AC-8017 100-Hz to 10-Hz Conversion Kit, AC-8018 10-Hz to 1-Hz Conversion Kit, and AC-8019 100-Hz to 1-Hz Conversion Kit.
Synthesizer 1-kHz decade A20	623-2080-003	X	X	
Synthesizer 10-kHz decade A21	623-2080-002	X	X	
Synthesizer 100-kHz decade A22	623-2080-001	X	X	

Table 1. Equipment Supplied/Configuration (Cont).

SUBASSEMBLY/CIRCUIT CARD		EXCITER		DESCRIPTION/FUNCTION
TITLE	PART NUMBER	HF-8014 622-3472-001	HF-8014A 622-3473-001	
Synthesizer output A23	635-4930-002	X	X	
Rfi filter A24	637-2712-001	X	X	
Sideboard assembly A25	634-8224-001	X	X	
Sideboard (P/O 634-8211-( ))	638-6617-001	X	X	
Cable assembly (P/O 634-8211-( ))	634-8210-001	X	X	Interconnects P2 and P11 with J13 (frequency control).
Cable assembly (P/O 634-8211-( ))	634-8212-001	X	X	Interconnects P3, P4, P5, and P6 with J13 (status control and display).
Synthesizer chassis assembly A27	634-8201-001	X	X	
Rf cable assembly J43/J29 (P/O A27)	637-1526-003	X	X	Interconnects J43 and J29 (118.8-MHz inj in).
Rf cable assembly J45/J28 (P/O A27)	637-1526-003	X	X	Interconnects J45 and J28 (variable inj in).
Rf cable assembly J44/J32 (P/O A24)	637-1526-004	X	X	Interconnects J44 and J32 (9.9-MHz inj in).
Rf cable assembly A1-if (P/O A27)	637-1529-001	X	X	Interconnects A27-E1 and J34 (450-kHz inj in).
Rf cable assembly B1-if (P/O A27)	637-1529-001	X	X	Interconnects A27-E1 and J39 (450-kHz inj in).
Rf cable assembly A2-if (P/O A27)	637-1529-001	X	X	Interconnects A27-E7 and J54 (456.29-kHz inj in).
Rf cable assembly B2-if (P/O A27)	637-1529-001	X	X	Interconnects A27-E5 and J55 (443.71-kHz inj in).
Synthesizer sideboard (P/O A27)	638-6973-001	X	X	
Synthesizer chassis (P/O A27)	634-8178-001	X	X	
Synthesizer bottom cover (P/O A27)	634-8186-001	X	X	
Synthesizer top cover	642-2409-001	X	X	
Oven standard, oscillator assembly A29	637-9135-001		X	Part of AC-8012 Oven Standard Kit (622-3460-001); 1-MHz oven standard.

Table 1. Equipment Supplied/Configuration (Cont).

SUBASSEMBLY/CIRCUIT CARD		EXCITER		DESCRIPTION/FUNCTION
TITLE	PART NUMBER	HF-8041 622-3472-001	HF-8014A 622-3473-001	
Frequency standard switch A30	646-6558-001		X	Can be switched for 100-kHz, 1-MHz, or 5-MHz external frequency standard. Automatically switches over from an external frequency reference input to the oven standard upon loss of the external frequency standard. Can be used only if oven standard is installed. Part of AC-8015 Frequency Standard Switch Kit (622-3499-001).
Power cable	426-1034-010	X	X	
Maintenance kit	637-1769-001	X	X	2-A fuse installed for 100- or 115-V ac operation. 1-A fuse installed for 215- or 230-V ac operation.
Wrench, hex 0.062 in (1 ea)	024-0058-000			
Wrench, hex 0.050 in (1 ea)	024-0057-000			
Fuse, 2A (5 ea)	<del>264-0305-000</del> <del>264-0728-000</del>			
Fuse, 1A (5 ea)	<del>264-4280-000</del> <del>264-0721-000</del>			
Lamps (2 ea)	262-1106-000			
Instruction sheet	637-1777-001			

AD-1

Table 2. Associated Equipment.

EQUIPMENT	TYPE	FUNCTION	CHARACTERISTICS
Headphones	Any	Provide headphone monitoring of the HF-8014( ) Exciter transmit audio.	Standard 600-ohm headphones
Microphone	Any	Provide voice audio input for HF-8014( ) Exciter voice transmissions.	200-ohm microphone
CW key	Any	Provide CW key input for HF-8014( ) Exciter CW transmissions.	
FSK modem	Any	Provide FSK signals for HF-8014( ) Exciter RTTY transmissions.	Low-impedance audio input

Table 2. Associated Equipment (Cont).

EQUIPMENT	TYPE	FUNCTION	CHARACTERISTICS
Exciter control	HF-8093 or equivalent	Provide serial data control signals to the HF-8014A Exciter in remote applications (not used for HF-8014 Exciter).	Provides serial data control signals using FSK, EIA RS-232C (CCITT V.24) or MIL-STD-188C signals. Selectable data rates: 75, 109, 150, 300, or 600 bauds using FSK signals.  75, 109, 150, 300, 600, 1200, 2400, 4800, 9600, or 19 200 bauds using RS-232C or MIL-STD-188C signals.
Power amplifier	Any	Amplify 200-mW exciter output to a usable rf transmission.	Compatible with 200-mW exciter output.

4. ACCESSORIES

For detailed information (including manufacturer's part number and physical description) pertaining to equipment mounting racks and preassembled interconnecting cables, refer to the following system instruction books:

<u>TITLE</u>	<u>PART NUMBER</u>
HF-80 1-kW Transmitter/ Transceiver Systems	523-0767370
HF-80 3-kW Transmitter/ Transceiver Systems	523-0767386

TITLE

PART NUMBER

HF-80 10-kW Transmitter/  
Transceiver Systems

523-0767402

5. OPTIONS

Options available for the HF-8014( ) Exciter are listed in table 3.

6. EQUIPMENT SPECIFICATIONS

Specifications for the HF-8014( ) Exciter are listed in table 4.

Table 3. Options.

OPTION	PART NUMBER	FUNCTION
AC-8012 Oven Standard Kit	622-3460-001	Internal oven frequency standard with a stability of $1 \times 10^{-8}$ over the specified operating temperature range. Implemented by adding oven oscillator assembly (637-9135-001), a 2-wire cable harness, a coaxial cable, and an external phase lock (635-0655-001).
AC-8013 External Standard Kit	622-3461-001	Permits operation from an external frequency of 100 kHz, 1 MHz, or 5 MHz as desired. Implemented by adding a coaxial cable harness with rf connector mounted on rear panel and installing an external phase lock (635-0655-001).
AC-8014 Frequency Display Kit	622-3470-001	Provides an LED display in 10-Hz increments of the frequency selected in the HF-8014( ) Exciter either locally or remotely. In local operation this display agrees with the frequency switchboard setting in the HF-8014( ) Exciter front panel. In remote operation, this display agrees with the frequency switchboard setting on the exciter control.
	622-3470-002	Same as 622-3470-001 except LED display is in 100-Hz increments.



Table 3. Options (Cont).

OPTION	PART NUMBER	FUNCTION
AC-8015 Frequency Standard Switch Kit	622-3499-001	Provides automatic switchover from an external frequency reference input to the oven-stabilized frequency standard upon loss of the external input. The nominal external input level should be 0.5 to 2.0 V ac into 50 ohms at 5.0 MHz, 1.0 MHz, or 100 kHz. When the kit is installed, a continuous 100-kHz output, 1.5 V ac nominal, is available at a BNC jack for peripheral equipment. This kit is intended for factory installation. The oven standard must be installed for the AC-8015 to operate.
AC-8017 100- to 10-Hz Tuning Conversion Kit	622-3453-001	10-Hz tuning increment capability. Implemented by installing a synthesizer 100/10-Hz decade card (623-2080-004) in the A19 slot by moving the synthesizer end decade card (635-0657-001) from the A19 slot to the A18 slot and by changing the front panel frequency switchboard from 635-0830-001 to 635-0830-002.
AC-8019 100- to 1-Hz Tuning Conversion Kit	622-3455-001	1-Hz tuning increment capability is recommended for processor-controlled units only. Implemented by installing two synthesizer 100/10-Hz decades (623-2080-004), one in the A19 slot and one in the A18 slot, by moving synthesizer end decade card (634-0657-001) from the A19 slot to the A17 slot, and by changing the front panel frequency switchboard from 635-0830-001 to 635-0830-002.

Table 4. Equipment Specifications.

CHARACTERISTIC	SPECIFICATION
Electrical	
Modes of operation	A3B/A9B/A3J/A7J (ISB), A3H (AME), A1/A0 (CW), and A3A (reinserted pilot carrier).
Frequency range	1.6000 kHz to 29.9999 MHz.
Tuning increments ✓	100 Hz, optional 10 Hz or for processor control applications 1 Hz.
Frequency stability ✓	Not less than $5 \times 10^{-7}$ over specified temperature range; drift rate of not more than $3 \times 10^{-8}$ per week.  Optional oven standard provides not less than $1 \times 10^{-8}$ over specified temperature range; drift rate not more than $1 \times 10^{-8}$ per week after 72 hours of continuous operation.  Optional external standard provides stability equal to the stability of the 100-kHz, 1-MHz, or 5-MHz external standard used; input impedance, 50 $\Omega$ ; input level, 0.1 to 1.0 V rms.
Frequency tune time	5 ms max; 2 ms nom.
Bandwidths	ISB, 2.85 kHz per sideband. AM and CW, 16-kHz bandpass filter with space provided for up to five additional filters.
RF output ✓	200-mW pep maximum, full gain into 50 $\Omega$ .

Table 4. Equipment Specifications (Cont).

CHARACTERISTIC	SPECIFICATION
Carrier levels	<p>Tune power: -3 dB from nominal full pep when controlled by power amplifier TGC.</p> <p>AM (A3H): -3 ±1 dB from tune power carrier (-6 dB from full pep).</p> <p>Suppressed carrier (A3J): -55 dB from full pep.</p> <p>Pilot carrier: 20 ±1 dB, adjustable over -13 to -23 dB, referenced to rated output.</p> <p>Peak clipping: peak clipping at if frequency adjustable over 0- to 12-dB range.</p>
Opposite sideband rejection	-60 dB from 1000 Hz of input signal (using standard SSB filters).
Spurious emissions	<p>At 50 kHz or more off carrier frequency, spurious emissions are suppressed as follows:</p> <ul style="list-style-type: none"> <li>a. NLT 70 dB below pep using HF-8020 1-kW Power Amplifier.</li> <li>b. NLT 80 dB below pep using HF-8021 3-kW Power Amplifier or HF-8022 10-kW Power Amplifier.</li> </ul> <p>Exceptions to the above: from 21.60 to 22.15 MHz carrier frequency, spurious emissions are suppressed NLT 70 dB below pep; from 26.65 to 28.00 MHz carrier frequency, spurious emissions are suppressed NLT 60 dB below pep.</p>
Intermodulation distortion	NLT 50 dB below either of two equal output tones (200-mW pep) for line audio input signals spaced 200 Hz or more apart.
CW keying rate	100 bauds maximum.
Audio circuits (all channels when in ISB)	Line input: 600 Ω ±10%, balanced; input signal in compression range produces full rf output. Compression range 15 dB minimum. Compression threshold adjustable between -26 and +10 dB mW.
Microphone	Dynamic type: 200 Ω ±10%, unbalanced; -55 dB mW, nominal, for rated output from power amplifier. Compression range 30 dB minimum.
Duty cycle	Continuous.
Power requirements	100/115/215/230 V ±10%, 47 to 420 Hz, single-phase ac, 80 watts maximum.
Serial control and monitor interface characteristics	
Output data levels	<p>FSK: -10 to +5 dB mW into 600 Ω, 0 dB mW nominal</p> <p>RS-232C/MIL-STD-188C: ±6 V dc ±1 V dc into 3 to 6 kΩ</p>
Input data levels	<p>FSK: -25 to +5 dB mW (15 dB snr min)</p> <p>RS-232C/MIL-STD-188C: ±6 V dc ±1 V dc</p>
Line output impedance	<p>FSK: 600 Ω nom</p> <p>RS-232C/MIL-STD-188C: 300 Ω max when transmitting, 50 kΩ min when not transmitting</p>

Table 4. Equipment Specifications (Cont).

CHARACTERISTIC	SPECIFICATION
Line input impedance	FSK: 600 $\Omega$ nom RS-232C/MIL-STD-188C: 47 k $\Omega$ nom
FSK tone frequencies	Mark: 1280 Hz Space: 2133 Hz
Data rates	FSK: 75, 109, 150, 300, 600 bauds RS-232C/MIL-STD-188C: 75, 109, 150, 300, 600, 1200, 2400, 4800, 9600, 19 200 bauds
Data format	Selectable 7-bit ASCII code or 8-bit character code
Line characteristics	FSK: 600 $\Omega$ , balanced RS-232C/MIL-STD-188C: unbalanced, line to ground
Environmental	
Temperature	Full performance: 0 to +50 $^{\circ}$ C (+32 to +122 $^{\circ}$ F) Reduced performance: -20 to 0 $^{\circ}$ C (-4 to +32 $^{\circ}$ F) Nonoperating: -57 to +71 $^{\circ}$ C (-71 to 160 $^{\circ}$ F)
Humidity	0 to 95% relative humidity
Altitude	Operating: 0 to 3048 m (10 000 ft). 0 to +50 $^{\circ}$ C (+32 to +122 $^{\circ}$ F); 0 to 4572 m (15 000 ft). 0 to +25 $^{\circ}$ C (+32 to +77 $^{\circ}$ F) Nonoperating: 0 to 12 192 m (40 000 ft). -57 to +71 $^{\circ}$ C (-71 to +160 $^{\circ}$ F)
Shock	Bench handling (MIL-STD-810C, procedure V, method 516.2)
Vibration	1.5 g, 5.5 to 55 Hz (MIL-STD-810C, procedure X, method 514.2)
Physical	
Size	177 mm (7 in) high x 483 mm (19 in) wide x 619 mm (24.4 in) deep with handles
Weight	21.8 kg (48 lb) max
Mounting	Desk-top cabinet or standard 483-mm (19-in) rack with optional slide mounting kit for rack.



Rockwell  
International

supplement

Collins Telecommunications Products Division

523-0770720-001218

1 January 1981

# HF-8014 Exciter

Printed in USA

## 1. GENERAL

The purpose of this supplement is to provide a general description of the HF-8014 Exciter (figure 1). When used with the HF-8014( ) Exciter Instruction Book (part number 523-0770718), this supplement provides the user with a complete instruction book on the HF-8014 Exciter.

## 2. DESCRIPTION

The HF-8014 Exciter has the characteristics listed in table 1. Equipment supplied in the HF-8014 Exciter and its configuration is listed in table 2. The function/description (if significant) of the cables/assemblies is listed in the HF-8014( ) Exciter instruction book description section.



TPA-2786-017

HF-8014 Exciter  
Figure 1

Table 1. HF-8014 Exciter Characteristics.

CHARACTERISTICS	HF-8014 EXCITER 622-3472-( )												
	-001												
Tuning: 100 Hz	X												
10 Hz													
1 Hz													
Modes: CW	X												
ISB	X												
AM	X												
Bandwidths (kHz):													
USB - A1	2.85												
UUSB - A2	2.85												
LSB - B1	2.85												
LLSB - B2	2.85												
16	X												
ISB 2-channel													
4-channel	X												
Remote control													
Oven standard													
External standard													
Frequency standard switch													
Frequency display													

Table 2. HF-8014 Exciter Equipment Supplied/Configuration.

SUBASSEMBLY/CIRCUIT CARD		HF-8014 EXCITER 622-3472-( )								
TITLE	PART NUMBER	-001								
Main chassis	634-8177-001	X								
Bottom cover	634-8179-001	X								
Top cover	634-8180-002	X								
Rear panel	634-9611-003	X								
Wiring harness	642-2407-001	X								
Wiring harness	642-2408-001	X								
Rf cable assembly, 450-kHz if	642-2454-001	X								
Rf cable assembly J22/J26	637-1525-004	X								
Rf cable assembly J27/J36	637-1526-003	X								
Power supply A1	635-9649-001	X								
Front panel assembly A2	634-8199-001 634-8199-002	X								
LED status display A2A1	635-0825-012	X								
Switch mounting board A2A2	638-6597-001	X								
Frequency switchboard A2A3	635-0830-001	X								
Frequency display A2A5	637-1781-006									
Transmit audio A3 (A2B2)	638-6476-003	X								
Transmit audio A4 (A1B1)	638-6476-001	X								
Channel B2 if A5	638-6636-003	X								
Channel A2 if A6	638-6636-002	X								
Channel B1 if A7	638-6636-001	X								
Channel A1 if A8	638-6659-001	X								
Rf translator A9	637-1768-002	X								
Control A10	638-6622-001	X								
Parallel input A11	642-3135-001	X								
Parallel output A12	642-3137-001	X								
Serial interface A13	638-6896-001	X								

Table 2. HF-8014 Exciter Equipment Supplied/Configuration (Cont).

SUBASSEMBLY/CIRCUIT CARD		HF-8014 EXCITER 622-3472-( )							
TITLE	PART NUMBER	-001							
Synthesizer voltage regulator A14	635-0656-001	X							
Synthesizer subcarrier generator A15	638-6962-001	X							
Synthesizer reference A16	642-2451-001	X							
External phaselock A16A4	635-0655-001								
Synthesizer end decade A19	635-0657-001	X							
Synthesizer 100/10-Hz decade	623-2080-004								
Synthesizer 1-kHz decade A20	623-2080-003	X							
Synthesizer 10-kHz decade A21	623-2080-002	X							
Synthesizer 100-kHz decade A22	623-2080-001	X							
Synthesizer output A23	635-4930-002	X							
Rfi filter A24	637-2712-001	X							
Sideboard assembly A25	634-8211-001	X							
Sideboard	638-6617-001	X							
Cable assembly	634-8210-001	X							
Cable assembly	634-8212-001	X							
Synthesizer chassis assembly A27	634-8021-001	X							
Rf cable assembly J43/J29	637-1526-003	X							
Rf cable assembly J45/J28	637-1526-003	X							
Rf cable assembly J44/J32	637-1526-014	X							
Rf cable assembly A1-if	637-1529-001	X							
Rf cable assembly B1-if	637-1529-001	X							
Rf cable assembly A2-if	637-1529-001	X							
Rf cable assembly B2-if	637-1529-001	X							
Synthesizer sideboard	638-6973-001	X							
Synthesizer chassis	634-8178-001	X							

Table 2. HF-8014 Exciter Equipment Supplied/Configuration (Cont).

SUBASSEMBLY/CIRCUIT CARD		HF-8014 EXCITER 622-3472-( )							
TITLE	PART NUMBER	-001							
Synthesizer bottom cover	634-8186-001	X							
Synthesizer top cover	634-2409-001	X							
Oven standard, oscillator assembly A29	637-9135-001								
Frequency standard switch A30	646-6558-001								
Power cable	426-1034-010	X							
Maintenance kit	637-1769-001	X							

Because of its flexibility, all configurations of the HF-8014 Exciter may not be listed in tables 1 and 2. Blank columns have been provided in the tables so that if your HF-8014 Exciter is not included, you may add it. The next revision to this supplement should contain your configuration.

**3. DIFFERENCE DATA**

All HF-8014 Exciters are similar except for options installed. Options are available in kit form or may be installed at the factory. These options are covered functionally in the HF-8014( ) Exciter theory section and in detail in the appropriate card/module sections.

Refer to table 2 for the differences in the HF-8014 Exciter complement. As a result of some options, the following subassembly differences should be noted.

a. With oven standard option installed, external phase-lock 635-0655-001 and oven oscillator assembly 637-9135-001 are used.

- b. With external standard option installed, external phase-lock 635-0655-001 and cable assembly W1 637-9136-001 are used.
- c. With frequency standard switch option installed (factory installation), external phase-lock 635-0655-001, oven oscillator assembly 637-9135-001, and frequency standard switch 646-6558-001 are used.
- d. With frequency display option installed (factory installation), frequency display A2A5 637-1781-006 and frequency display cable A2W1 634-8289-001 are used.
- e. With 10-Hz tuning option installed, synthesizer end decade A19 635-0657-001 is placed in the A18 assembly position, and a synthesizer 100/10-Hz decade 623-2080-004 is added in the A19 assembly position.
- f. With 1-Hz tuning option installed, synthesizer end decade A19 635-0657-001 is placed in the A17 assembly position and two synthesizer 100/10-Hz decades 623-2080-004 are added, one in the A19 assembly position and one in the A18 assembly position. This option used only with a processor control tuning.





Rockwell  
International

supplement

# HF-8014A Exciter

Collins Telecommunications Products Division

523-0770721-001218

1 January 1981

Printed in USA

## 1. GENERAL

The purpose of this supplement is to provide a general description of the HF-8014A Exciter (figure 1). When used with the HF-8014( ) Exciter Instruction Book (part number 523-0770718), this supplement provides the user with a complete instruction book on the HF-8014A Exciter.

## 2. DESCRIPTION

The HF-8014A Exciter has the characteristics listed in table 1. Equipment supplied in the HF-8014A Exciter and its configuration is listed in table 2. The function/description (if significant) of the cables/assemblies is listed in the HF-8014( ) Exciter instruction book description section.

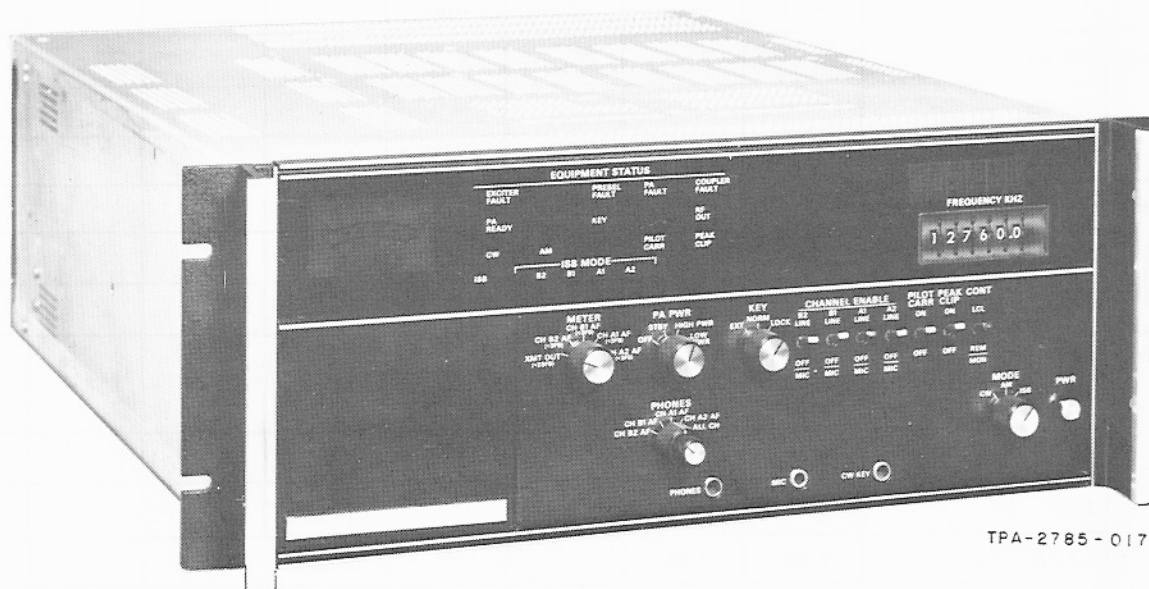

HF-8014A Exciter  
Figure 1

Because of its flexibility, all configurations of the HF-8014A Exciter may not be listed in tables 1 and 2. Blank columns have been provided in the tables so that if your HF-8014A Exciter is not included, you may add it. The next revision to this supplement should contain your configuration.

### 3. DIFFERENCE DATA

All HF-8014A Exciters are similar except for options installed. Options are available in kit form or may be installed at the factory. These options are covered functionally in the HF-8014( ) Exciter theory section and in detail in the appropriate card/module sections.

Refer to table 2 for the differences in the HF-8014A Exciter complement. As a result of some options, the following subassembly differences should be noted.

a. With oven standard option installed, external phase-lock 635-0655-001 and oven oscillator assembly 637-9135-001 are used.

- b. With external standard option installed, external phase-lock 635-0655-001 and cable assembly W1 637-9136-001 are used.
- c. With frequency standard switch option installed (factory installation), external phase-lock 635-0655-001, oven oscillator assembly 637-9135-001, and frequency standard switch 646-6558-001 are used.
- d. With frequency display option installed (factory installation), frequency display A2A5 637-1781-006 and frequency display cable A2W1 634-8289-001 are used.
- e. With 10-Hz tuning option installed, synthesizer end decade A19 635-0657-001 is placed in the A18 assembly position and a synthesizer 100/10-Hz decade 623-2080-004 is added in the A19 assembly position.
- f. With 1-Hz tuning option installed, synthesizer end decade A19 635-0657-001 is placed in the A17 assembly position and two synthesizer 100/10-Hz decades 623-2080-004 are added, one in the A19 assembly position and one in the A18 assembly position. This option used only with a processor control tuning.

Table 1. HF-8014A Exciter Characteristics.

CHARACTERISTICS		HF-8014A EXCITER 622-3473-( )							
		-001	-002	-003	-004				
Tuning:	100 Hz	X	X	X	X				
	10 Hz								
	1 Hz								
Modes:	CW	X	X	X	X				
	ISB	X	X	X	X				
	AM	X	X	X	X				
Bandwidths (kHz):									
	USB - A1	2.85	2.85	2.85	2.85				
	UUSB - A2	2.85	2.85						
	LSB - B1	2.85	2.85	2.85					
	LLSB - B2	2.85	2.85						
	16	X	X	X	X				
ISB:	2-channel			X					
	4-channel	X	X						

Table 1. HF-8014A Exciter Characteristics (Cont).

CHARACTERISTICS	HF-8014A EXCITER 622-3473-( )							
	-001	-002	-003	-004				
Remote control	X	X	X	X				
Oven standard		X	X	X				
External standard		X	X	X				
Frequency standard switch		X	X	X				
Frequency display		X	X	X				

Table 2. HF-8014A Exciter Equipment Supplied/Configuration.

SUBASSEMBLY/CIRCUIT CARD		HF-8014A EXCITER 622-3473-( )							
TITLE	PART NUMBER	-001	-002	-003	-004				
Main chassis	634-8177-001	X	X	X	X				
Bottom cover	634-8179-001	X	X	X	X				
Top cover	634-8180-002	X	X	X	X				
Rear panel	634-7611-003	X	X	X	X				
Wiring harness	642-2407-001	X	X	X	X				
Wiring harness	642-2408-001	X	X	X	X				
Rf cable assembly J40/J22	637-1525-002	X							
Rf cable assembly, 450-kHz if	642-2454-001	X	X	X	X				
Rf cable assembly J22/J26	637-1525-004	X	X	X	X				
Rf cable assembly J27/J36	637-1526-003	X	X	X	X				
Power supply A1	635-9649-001	X	X	X	X				
Front panel assembly A2	634-8199-001	X							
	634-8199-002		X	X	X				
LED status display A2A1	635-0825-012	X	X	X	X				
Switch mounting board A2A2	638-6597-001	X	X	X	X				
Frequency switchboard A2A3	635-0830-001	X	X	X	X				
Frequency display A2A5	637-1781-006		X	X	X				
Transmit audio A3 (A2B2)	638-6476-003	X	X						

Table 2. HF-8014A Exciter Equipment Supplied/Configuration (Cont).

SUBASSEMBLY/CIRCUIT CARD		HF-8014A EXCITER 622-3473-( )							
TITLE	PART NUMBER	-001	-002	-003	-004				
Transmit audio A4 (A1B1)	638-6476-001	X	X	X	X				
Channel B2 if A5	638-6636-003	X	X						
Channel A2 if A6	638-6636-002	X	X						
Channel B1 if A7	638-6636-001	X	X	X					
Channel A1 if A8	638-6659-001	X	X	X	X				
Rf translator A9	637-1768-002	X	X	X	X				
Control A10	638-6622-001	X	X	X	X				
Parallel input A11	642-3135-001	X	X	X	X				
Parallel output A12	642-3137-001	X	X	X	X				
Serial interface A13	638-6896-001	X	X	X	X				
Synthesizer voltage regulator A14	635-0656-001	X	X	X	X				
Synthesizer subcarrier generator A15	638-6962-001	X	X						
Synthesizer reference A16	642-2451-001	X	X	X	X				
External phase-lock A16A4	635-0655-001		X	X	X				
Synthesizer end decade A19	635-0657-001	X	X	X	X				
Synthesizer 100/10-Hz decade	623-2080-004								
Synthesizer 1-kHz decade A20	623-2080-003	X	X	X	X				
Synthesizer 10-kHz decade A21	623-2080-002	X	X	X	X				
Synthesizer 100-kHz decade A22	623-2080-001	X	X	X	X				
Synthesizer output A23	635-4930-002	X	X	X	X				
Rfi filter A24	637-2712-003	X	X	X	X				
Sideboard assembly A25	634-8211-001	X	X	X	X				
Sideboard	638-6617-001	X	X	X	X				
Cable assembly	634-8210-001	X	X	X	X				
Cable assembly	634-8212-001	X	X	X	X				
Rf cable assembly J43/J29	637-1526-003	X	X	X	X				
Rf cable assembly J45/J28	637-1526-003	X	X	X	X				
Rf cable assembly J44/J32	637-1526-014	X	X	X	X				
Rf cable assembly A1-if	637-1529-001	X	X	X	X				
Rf cable assembly B1-if	637-1529-001	X	X	X	X				

Table 2. HF-8014A Exciter Equipment Supplied/Configuration (Cont).

SUBASSEMBLY/CIRCUIT CARD		HF-8014A EXCITER 622-3473-( )							
SUBASSEMBLY/CIRCUIT CARD	PART NUMBER	-001	-002	-003	-004				
Rf cable assembly A2-if	637-1529-001	X	X	X	X				
Rf cable assembly B2-if	637-1529-001	X	X	X	X				
Synthesizer sideboard	638-6973-001	X	X	X	X				
Synthesizer chassis	634-8178-001	X	X	X	X				
Synthesizer bottom cover	634-8186-001	X	X	X	X				
Synthesizer top cover	634-2409-001	X	X	X	X				
Oven standard, oscillator assembly A29	637-9135-001		X	X	X				
Frequency standard A30	646-6558-001		X	X	X				
Power cable	426-1034-010	X	X	X	X				
Maintenance kit	637-1769-001	X	X	X	X				



Rockwell  
International

installation

# HF-8014( ) Exciter

Collins Telecommunications Products Division

523-0770722-001218

1 January 1981

Printed in USA

## table of contents

<i>Paragraph</i>	<i>Page</i>
1. <i>General</i> .....	1
2. <i>Unpacking and Inspection</i> .....	1
3. <i>Preinstallation Check and Requirements</i> .....	1
3.1 <i>Strapping</i> .....	1
3.1.1 <i>Input Power</i> .....	1
3.1.2 <i>Remote Control (HF-8014( ) Only)</i> .....	1
3.1.3 <i>Address (HF-8014A Only)</i> .....	3
3.1.4 <i>Frequency Standard</i> .....	4
3.2 <i>Audio Inputs</i> .....	7
3.3 <i>Operation</i> .....	7
4. <i>Cabling</i> .....	7
4.1 <i>Exciter to HF-8093 Exciter Control (HF-8014A Only)</i> .....	7
4.2 <i>Multiple Exciters to Remote Control (HF-8014A Only)</i> .....	7
4.3 <i>Exciter to Primary Power Source</i> .....	7
4.4 <i>Exciter to External Key Line</i> .....	7
4.5 <i>Exciter to Power Amplifier</i> .....	7
4.5.1 <i>HF-8020 1-kW Power Amplifier</i> .....	7
4.5.2 <i>HF-8021/8022 3- or 10-kW Power Amplifier</i> .....	8
4.6 <i>Exciter to External Frequency Standard</i> .....	8
4.7 <i>Exciter to Preselector</i> .....	8
5. <i>Installation Procedures</i> .....	8
5.1 <i>Installation of Slide Mounts</i> .....	8
6. <i>Postinstallation Check</i> .....	8

HF-8014( ) Exciter

523-0770722-001218



# installation

## 1. GENERAL

The HF-8014( ) Exciter is ready, as shipped, for mounting in a 178-mm-(7-in-) high space in a standard 483-mm (19-in) equipment rack. This section contains information for installing the exciter in a rack and making it operational.

All interconnecting cables are attached to the exciter at the rear panel. Headphone, microphone, and CW jacks are located on the front panel for operator convenience.

The HF-8014( ) Exciter operates with natural convective cooling in single-unit installations. In multiple-unit installations or where other heat-producing equipment is installed in the same cabinet, it is desirable to install a cabinet blower to remove hot air and prevent excessive temperature buildup.

### **Note**

For detailed information (including manufacturer's part number and physical description) pertaining to equipment mounting racks and preassembled interconnecting cables, refer to the following system instruction books.

<u>TITLE</u>	<u>PART NUMBER</u>
HF-80 1-kW Transmitter/ Transceiver Systems	523-0767370
HF-80 3-kW Transmitter/ Transceiver Systems	523-0767386
HF-80 10-kW Transmitter/ Transceiver Systems	523-0767402

## 2. UNPACKING AND INSPECTION

Unpack the HF-8014( ) Exciter carefully and check each item received against the shipping invoice. Inspect the items for evidence of damage during ship-

ment. All claims for damage in shipment should be filed promptly with the transportation company involved. If claims for damage are filed, save the original packing cases and materials.

## 3. PREINSTALLATION CHECK AND REQUIREMENTS

### 3.1 Strapping

#### 3.1.1 Input Power

#### **Caution**

Do not operate the primary input voltage selector switches with power applied. Be sure switches are in proper position with proper fuse installed before applying.

Do not remove or install plug-in cards or modules with power on. Damage to cards or modules may result.

Connect the ground terminal located on the rear panel to a ground strap that is securely connected to earth ground. (Ground strap should be #14 AWG or larger.)

Switches are provided for strapping the unit for the desired primary input power. The unit may be operated from 100, 115, 215, or 230 volts ac, nominal input. In the lower left corner of the rear panel, set the primary input voltage selector switches to the position corresponding to the value nearest the primary input voltage. Figure 1 shows the switches set to the 115-volt position.

#### 3.1.2 Remote Control (HF-8014( ) Only)

Both the exciter and the associated exciter control or processor must operate at the same baud rate and signaling format. This is accomplished by the proper strapping of the serial interface, parallel output, and parallel input cards using the dipswitches and straps provided.

Figure 2 is a partial view of the serial interface card with the dipswitches shown. These switches control



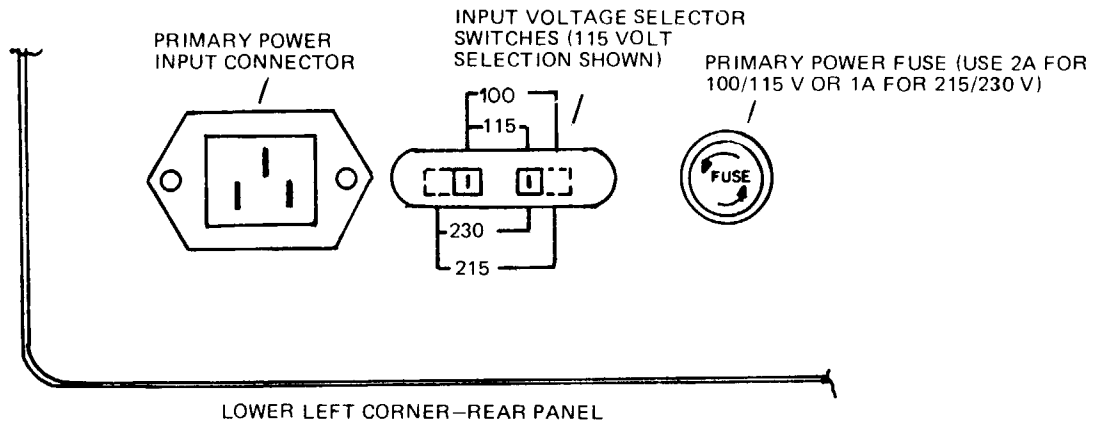

TP5-2055-011

Primary Input Voltage Selector Switches  
Figure 1

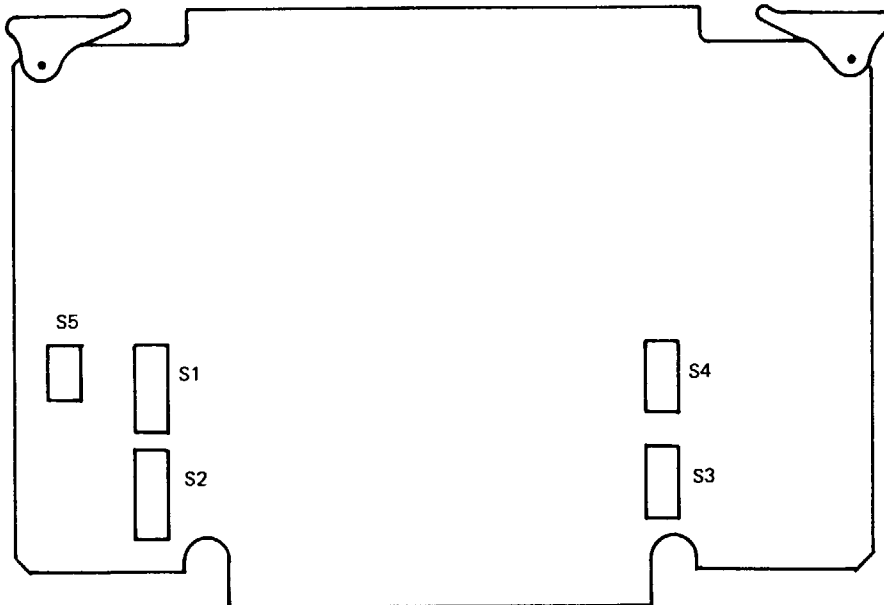

TPA-2674-011

Serial Interface Dipswitch Location  
Figure 2

baud rate, FSK/RS-232C signaling, word format, EIA/MIL-STD-188C polarity, parity, number of stop bits, application, and address recognition enable/disable as follows. (Note: Switch #1 of each dipswitch is toward the top of the card.)

a. Baud Rate

All eight of the switches in S1 and switches 1, 2, and 3 of S2 control the baud rate. Closing one and only one of these switches will select the baud rate as shown in table 1.

Table 1. Baud Rate Selection.

DIPSWITCH	SWITCH	BAUD RATE
S1	1	19 200
S1	2	9 600
S1	3	4 800
S1	4	2 400
S1	5	1 200
S1	6	600
S1	7	300
S1	8	150
S2	1	109
S2	2	75
S2	3	External

b. EIA/MIL-STD-188C Polarity

Open switch 4 of S2 for EIA data polarity and close switch 4 of S2 for MIL-STD-188C polarity.

c. Exciter Operation Strapping

Open switch 5 of S2 on the serial interface card.

d. 8-BIT/ASCII Word Format, Parity, and Number of Stop Bits

Switches 6, 7, and 8 of S2 control the basic character format according to table 2.

e. FSK/RS-232C Signaling

Dipswitches S3 and S4 control the type of signaling. Close only switches 1, 2, and 3 of S3 and S4 for FSK. (Note: For FSK signaling, EIA data polarity should be selected. See 3.1.2b.) For RS-232C signaling, close only switches 4, 5, and 6 of S3 and S4.

f. Address Recognition Enable/Disable

Open switch 1 of S5 to enable address recognition. Close switch 1 of S5 to disable address recognition.

Table 2. Format Selection.

*S2 SWITCH			WORD FORMAT	PARITY	NUMBER OF STOP BITS
8	7	6			
C	C	C	ASCII	Even	2
C	C	O	ASCII	Odd	2
C	O	C	ASCII	Even	1
C	O	O	ASCII	Odd	1
O	C	C	8-bit	None	2
O	C	O	8-bit	None	1
O	O	C	8-bit	Even	1
O	O	O	8-bit	Odd	1

\*O = Open  
C = Closed

When address recognition is disabled, the exciter or control will accept a word with any address if the word is otherwise correct.

g. Parallel Input Strapping (Refer to figure 3.)

Figure 3 is a partial view of the parallel input card with dipswitch location shown. Close S1 switches 1 thru 8 and S2 switch 1. All other switches are open.

h. Parallel Output Strapping

The parallel output card must be strapped for proper operation at initial installation and/or following testing and troubleshooting. Strapping is accomplished using jumper clips over the square pins marked E1 through E6.

Place one jumper connector on each of the square pin pairs labeled E1 thru E4.

Pin pair E5 is strapped between the middle and top pins for a flashing fault indicator or strapped between the middle and bottom pins for a non-flashing fault indicator.

Pin pair E6 is strapped between the middle and left pins.

3.1.3 Address (HF-8014A Only)

The ADDRESS switch on the HF-8093 Exciter Control front panel develops a 4-bit binary output. Each exciter must be strapped, at interconnecting cable connector J14, to correspond to the address bit pattern for that unit. (When a processor is used to control the exciter, up to 32 units may be controlled using a 5-bit binary output.) Figure 4 shows the strapping for the

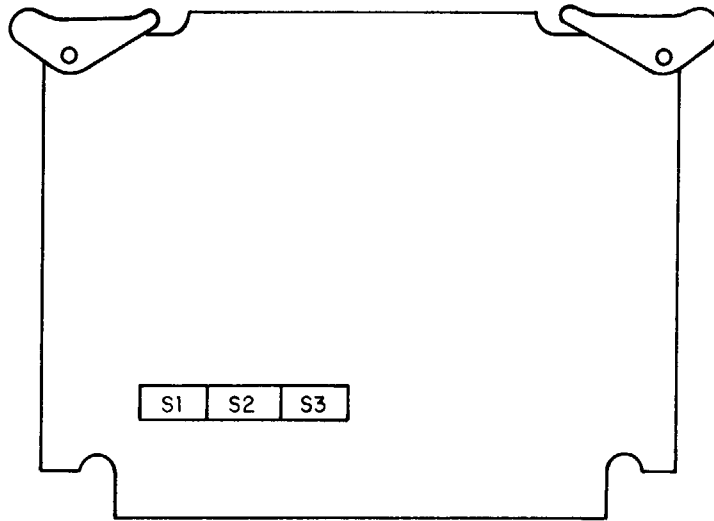

TPA-2835-011

*Parallel Input Dipswitch Location  
Figure 3*

connector pins associated with each address. Connect a short jumper wire between pins 9-13, as applicable, and ground (pin 22 and/or 24) on the wiring harness connector mating J14 on the exciter.

In a single exciter installation where an HF-8093 Exciter Control operates one-to-one with an HF-8014A Exciter, no strapping is needed. Address 0 (00000) is set by leaving all address pins open. In this case, the ADDRESS selector on the HF-8093 Exciter Control must be set at 0.

### 3.1.4 Frequency Standard

#### 3.1.4.1 Internal Standard

A temperature-compensated crystal oscillator provides an internal 100-kHz frequency standard. To use the internal frequency standard, the strap on synthesizer reference A16 must be set to the INT (internal) position. Refer to figure 5 for placement of strap.

#### 3.1.4.2 Oven Standard

**Note**

The strapping requirements are the same with a factory installed oven standard as with a field installed AC-8012 Oven Standard Kit.

To use the oven standard, the strap on synthesizer reference A16 must be set to the EXT (external) position and the strap on external phase-lock A16A4 must be set to the 100 kHz position. Refer to figure 5 for placement of straps.

#### 3.1.4.3 External Frequency Standard

**Note**

The strapping requirements are the same with a factory installed external frequency standard option as with a field installed AC-8013 External Standard Kit.

WIRING HARNESS CONNECTOR MATING  
WITH J14 ON REAR PANEL OF REMOTE UNIT

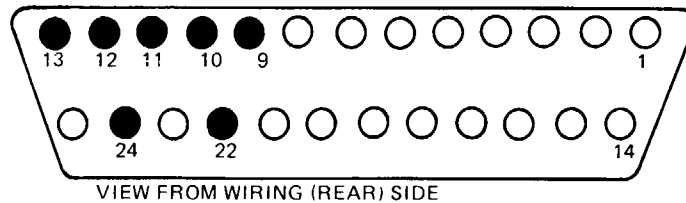

ADDRESS NUMBER	REMOTE UNIT STRAPPING REQD FOR ADDRESS RECOGNITION				
	A5	A4	A3	A2	A1
0	-	-	-	-	-
1	-	-	-	-	X
2	-	-	-	X	-
3	-	-	-	X	X
4	-	-	X	-	-
5	-	-	X	-	X
6	-	-	X	X	-
7	-	-	X	X	X
8	-	X	-	-	-
9	-	X	-	-	X
10	-	X	-	X	-
11	-	X	-	X	X
12	-	X	X	-	-
13	-	X	X	-	X
14	-	X	X	X	-
15	-	X	X	X	X
16	X	-	-	-	-
17	X	-	-	-	X
18	X	-	-	X	-
19	X	-	-	X	X
20	X	-	X	-	-
21	X	-	X	-	X
22	X	-	X	X	-
23	X	-	X	X	X
24	X	X	-	-	-
25	X	X	-	-	X
26	X	X	-	X	-
27	X	X	-	X	X
28	X	X	X	-	-
29	X	X	X	-	X
30	X	X	X	X	-
31	X	X	X	X	X

X INDICATES PIN STRAPPED TO GROUND  
(PIN 22 OR 24).  
-INDICATES OPEN (NO STRAP REQUIRED).

TPA-2578-011

Strapping for Unit Address  
Figure 4

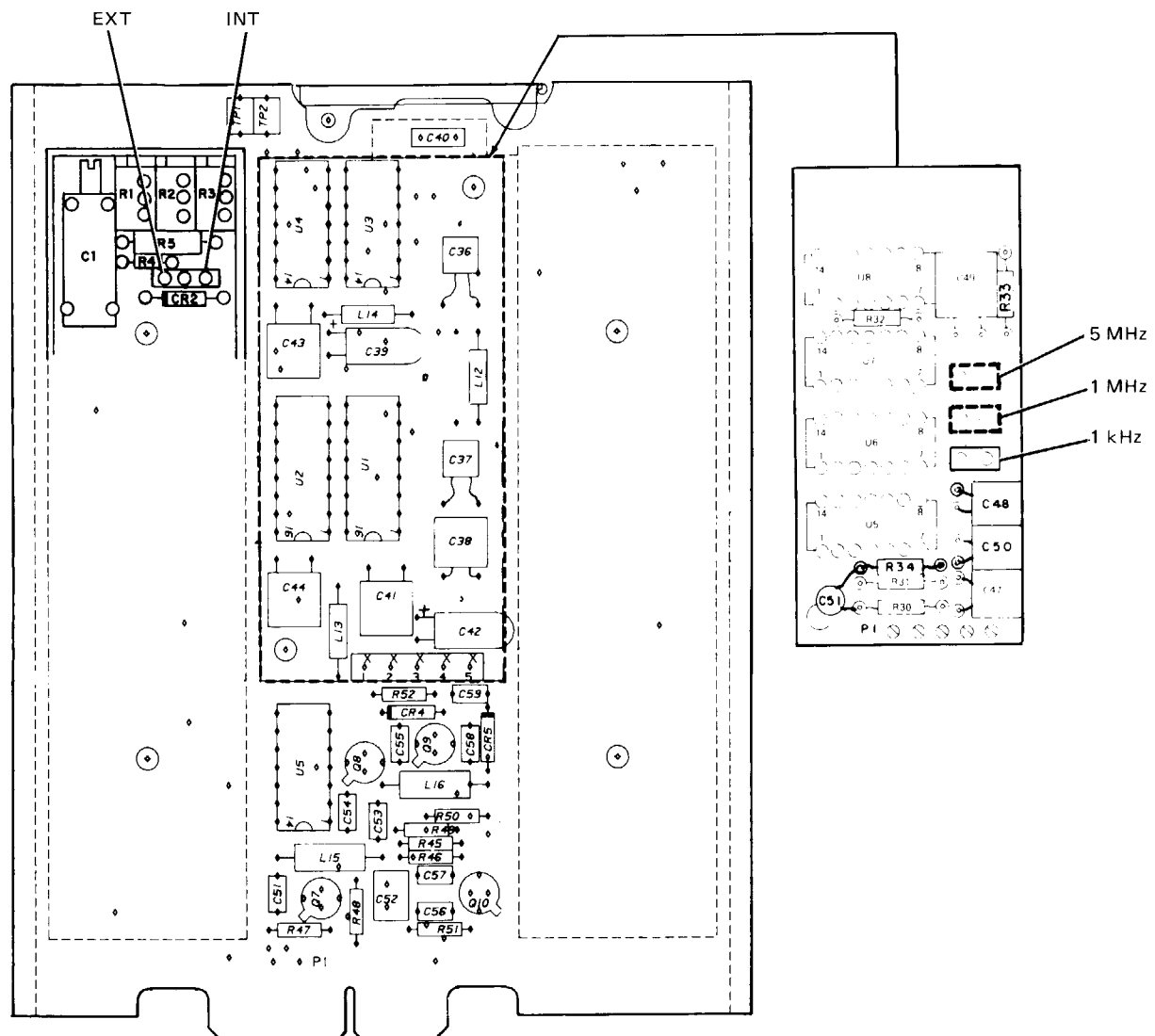

TPA-2973-019

Strapping for External Frequency Standard  
Figure 5

To use the external frequency standard (frequency standard switch not installed), the strap on synthesizer reference A16 must be set to the EXT (external) position and the strap on external phase-lock A16A4 must be set to the frequency position of the external standard (100-kHz, 1-MHz, or 5-MHz). Refer to figure 5 for placement of straps.

#### 3.1.4.4 Frequency Standard Switch

##### Note

The strapping requirements are the same with a factory installed frequency standard switch option as with a field installed AC-8015 Frequency Standard Switch Kit.

To use the frequency standard switch, the strap on synthesizer reference A16 must be set to the EXT (external) position and the strap on external phase-lock A16A4 must be set to the 100-kHz position. Refer to figure 5 for placement of straps.

To enable the use of external standard, the frequency selector switch on frequency standard switch A30 must set to the frequency position of the external standard (100-kHz, 1-MHz or 5-MHz).

#### 3.2 Audio Inputs

The transmit line audio outputs are adjusted at the factory so that -15 dB mW audio input corresponds to compression threshold. If your requirements for audio inputs are different from these, make line audio adjustments as outlined in the maintenance section of this instruction book.

#### 3.3 Operation

The HF-8014( ) Exciter operation was within the specified standards when the unit was shipped from the factory. The minimum performance test in the maintenance section should be performed to ensure that the equipment is operating within specifications.

### 4. CABLING (Refer to figure 6.)

#### 4.1 Exciter to HF-8093 Exciter Control (HF-8014A Only)

Maximum allowable separation between the exciter control and exciter is dependent upon the characteristics of the transmission lines used, the method of signaling, and the transmission data rates selected. When using FSK signaling and #16 AWG

shielded twisted-pair cable or field wire, maximum line length should be not more than 8 kilometers (5 miles). Transmission of the FSK data signals over private carrier leased lines, commercial telephone lines, microwave links, or satellite communications links permits unlimited separation between the exciter control and exciter. When using RS-232C or MIL-STD-188C signaling, maximum line length should be not more than 152 metres (500 feet).

Preassembled cables are available from Rockwell-Collins as part of kit AC-8091 (part number 622-3449- ( )) for use in installations with the exciter control and exciter.

#### 4.2 Multiple Exciters to Remote Control (HF-8014A Only)

Remote control of multiple exciters is accomplished by connecting in parallel all control data bus (J14-2 and J14-6) and monitor data bus (J14-3 and J14-16) of the exciters. Each exciter must be strapped for a unique address, as described in paragraph 3.1.3. The exciters must also be strapped for the same data rates, same parity, and same signal levels. (The signal level strapped must be either RS-232C or MIL-STD-188C; FSK cannot be used for multiple exciter systems.)

#### 4.3 Exciter to Primary Power Source

Separation between exciter and primary power source (100, 115, 215, 230 V ac) should be kept to a minimum. A preassembled power cable is supplied as a part of the HF-8014( ) Exciter.

#### 4.4 Exciter to External Key Line

The exciter can be keyed from rear panel EXT KEY terminal TB2-6. When the front panel KEY switch is in the EXT position, a ground key signal applied to TB2-6 keys the exciter.

#### 4.5 Exciter to Power Amplifier

Separation between exciter and power amplifier should be kept to a minimum. Preassembled cables are available from Rockwell-Collins for use in installations where an HF-8020 1-kW Power Amplifier, an HF-8021 3-kW Power Amplifier, or an HF-8022 10-kW Power Amplifier is used.

##### 4.5.1 HF-8020 1-kW Power Amplifier

Preassembled cable (AC-8072 (part number 622-3422- ( )) is available from Rockwell-Collins for use in installations with the exciter and 1-kW power amplifier

(1-kW power supply). A BNC-to-BNC rf cable is also required for exciter to 1-kW power amplifier installations.

If a preselector is used with the exciter, the BNC-to-BNC rf cable is connected to the preselector transmit rf input, and a second rf cable is required between the preselector transmit rf output and the 1-kW power amplifier.

#### **4.5.2 HF-8021/8022 3- or 10-kW Power Amplifier**

Preassembled cable (AC-8074 (part number 622-3433- ( )) is available from Rockwell-Collins for use in installations with the exciter and 3- or 10-kW power amplifier. A BNC-to-BNC rf cable is also required for exciter to 3- or 10-kW power amplifier installations.

If a preselector is used with the exciter, the BNC-to-BNC rf cable is connected to the preselector transmit rf input, and a second rf cable is required between the preselector transmit rf output and the 3- to 10-kW power amplifier.

#### **4.6 Exciter to External Frequency Standard**

Separation between exciter and external frequency standard should be kept to a minimum. A BNC-to-BNC cable is required.

#### **4.7 Exciter to Preselector**

Separation between the exciter and preselector should be kept to a minimum. Preassembled cables are available from Rockwell-Collins for use in installations using the preselector.

Preassembled cable (AC-8060 (part number 622-3456- ( )) is available from Rockwell-Collins for use in installations with the exciter and preselector. A BNC-to-BNC rf cable is also required for exciter-to-preselector installations.

## **5. INSTALLATION PROCEDURES**

Figure 7 shows the outline and mounting dimensions of the HF-8014( ) exciter. The HF-8014( ) Exciter has standard 483-mm (19-in) rack mounting characteristics and can be mounted using four mounting screws through the edges of the front panel; however, on all rack mounting configurations, slide mounting is recommended for ease of service and side support. When installation is complete, ensure that all electrical connections are made (including strapping) and that all dust covers and shields are in place.

### **5.1 Installation of Slide Mounts**

- a. Refer to figures 7 and 8. Attach the CA-8022 Mounting Kit (slide rails) to the proper location in the CA-8020( ) Equipment Cabinet and to the HF-8014( ) Exciter.
- b. Lift the exciter, position it squarely, and engage the slides of the mounting kit. Slide the exciter completely into the cabinet to assure that the slides function properly.
- c. Refer to cabling instructions of paragraph 4, and make the necessary cable connections as applicable to your unit.
- d. Connect a ground strap (#14 AWG or larger) from the GND terminal, located on the rear of the exciter, to a suitable ground point in the equipment cabinet. Be sure that the cabinet ground point is free of pain or foreign material.
- e. Slide the exciter into place in the equipment cabinet, and secure it with four screws on each side of the front panel.

## **6. POSTINSTALLATION CHECK**

There is no postinstallation check to be performed on the HF-8014( ) Exciter as a unit. The operation procedures presented in the operation section of this instruction book may be used as a postinstallation operational check.

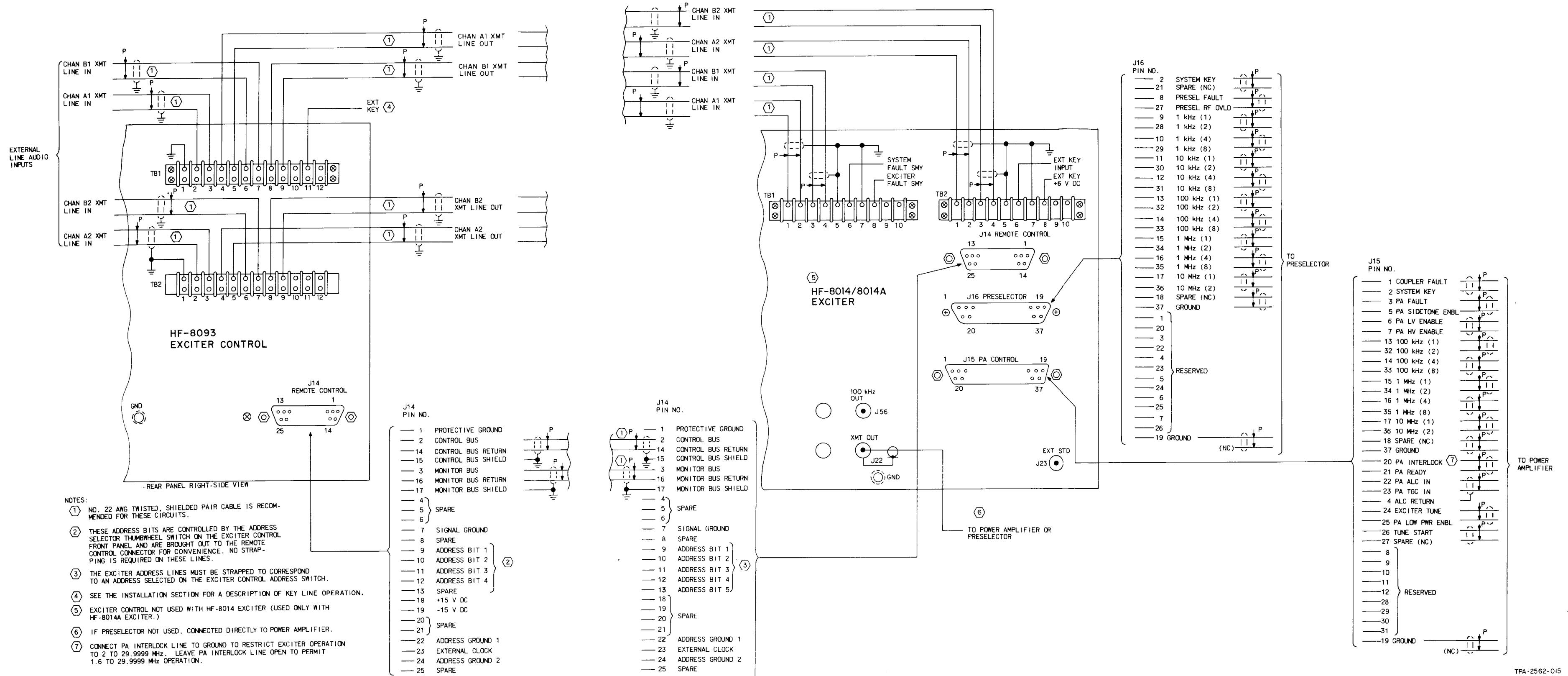

HF-8014( ) Exciter, Typical Installation Figure 6



- NOTES:
1. UNLESS OTHERWISE SPECIFIED, DIMENSIONS ARE IN MILLIMETRES [INCHES].
  2. WEIGHT: 21.3 ± 1.4 kg [47 ± 3 LB].
  3. MATING CONNECTORS ARE FOR REF ONLY. WEIGHT AND CENTER OF GRAVITY DOES NOT INCLUDE MATING CONNECTORS.
  4. NO EXTERNAL COOLING AIR REQUIRED.
  5. PRIMARY POWER REQUIREMENTS: 100/115/215/230 V AC ± 10%; SINGLE PHASE 47-420 Hz ± 5%; MAX POWER CONSUMPTION: 80 WATTS.
  6. ⊙ INDICATES CENTER OF GRAVITY.

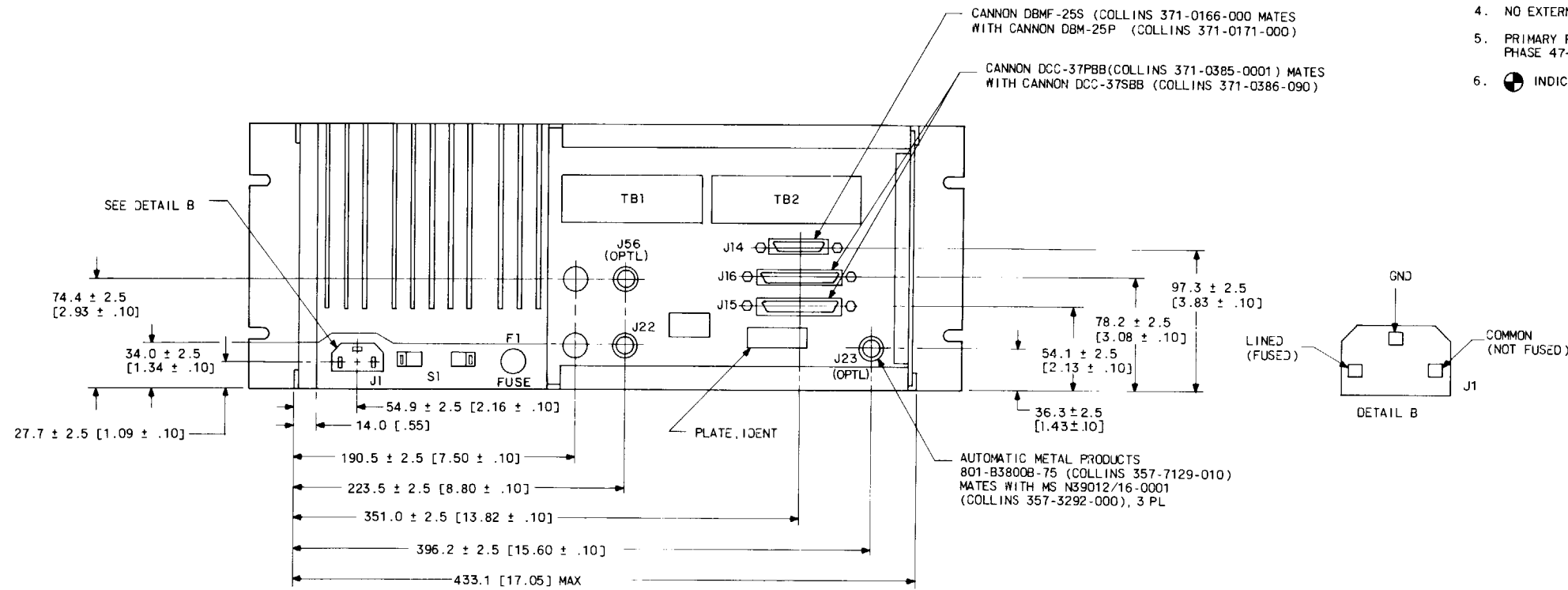

CONN NO	HF-8014 EXCITER 622-3472-( )	HF-8014A EXCITER 622-3473-( )
J14	1	1
J15	1	1
J16	1	1
J22	1	1
J23	OPTL	OPTL
J56	OPTL	OPTL

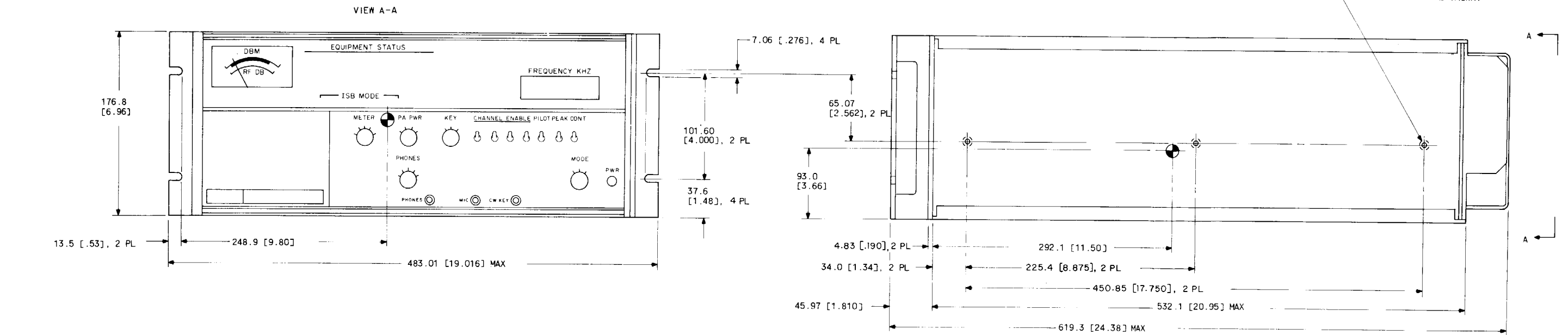

TPA-2852-014

HF-8014( ) Exciter,  
Outline and Mounting Dimensions  
Figure 7

NOTES:

- ① SLIDE BRACKETS MOUNT TO REAR SURFACE OF FRONT CABINET RAILS AND FRONT SURFACE OF REAR RAILS.
- ② a. FOR CABINETS WITH THREADED MOUNTING HOLES USE SCREWS AND FLAT WASHERS FROM BRACKET SIDE INTO CABINET. SCREW MUST NOT PROJECT BEYOND PANEL MOUNTING SURFACE.  
b. FOR CABINETS WITH CLEARANCE HOLES IN THE RAILS, THE HOLES USED FOR MOUNTING THE SLIDE BRACKETS MUST BE COUNTERSUNK AND FLAT HEAD SCREWS USED FOR MOUNTING.
- ③ DIMENSIONS ARE IN MILLIMETRES [INCHES].

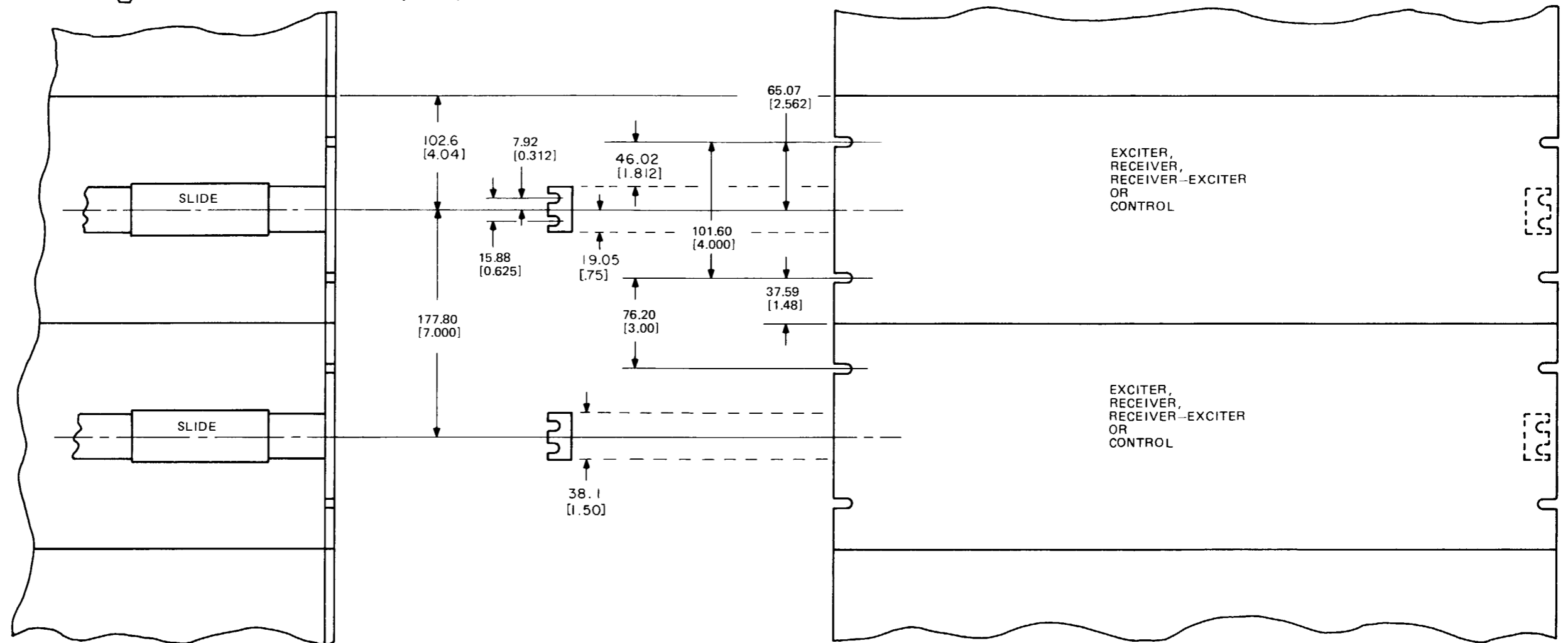

TP5-1869-013

Installation of Slides in Rack Mounts  
Figure 8



Rockwell  
International

operation

# HF-8014( ) Exciter

Collins Telecommunications Products Division

523-0770723-001218

1 January 1981

Printed in USA

## table of contents

<i>Paragraph</i>	<i>Page</i>
<b>1. General</b> .....	1
<b>2. Controls and Indicators</b> .....	1
<b>3. Operating Procedures</b> .....	1
3.1 Audio Adjustments .....	1
3.2 Normal (Local) Operating Procedures .....	1
3.2.1 General .....	1
3.2.2 Turn-On Procedures .....	9
3.2.3 CW Operation .....	10
3.2.4 AM Operation .....	10
3.2.5 ISB Operation .....	10
3.3 Fault Clearing Procedures .....	10
3.3.1 Exciter Fault .....	10
3.3.2 PA Fault .....	10
3.3.3 Coupler Fault .....	11
3.3.4 Preselector Fault .....	11
3.3.5 System Fault With Lockout .....	11
<b>4. Remote Operation (HF-8014A Only)</b> .....	11
4.1 General .....	11
4.2 Operating Procedures Using the HF-8093 Exciter Control .....	11
4.3 Operating Characteristics .....	11
4.3.1 Power Failure and Initialization .....	11
4.3.2 CONT Switch Operation .....	12
4.3.3 Address Selection .....	12
4.3.4 BUSY Indicator Operation .....	12
4.3.5 No Indication of Monitor Response .....	12
4.3.6 Polling Operation .....	12
4.3.7 Control and Monitor Data Transmission .....	13



## 1. GENERAL

All controls and indicators necessary for operation of a transmitter system are located on the front panel of the HF-8014( ) Exciter. Operation of the exciters differs only in that the HF-8014A Exciter can be controlled locally or remotely using an HF-8093 Exciter Control or processor while the HF-8014 Exciter must be operated locally.

When the HF-8014A Exciter is connected to a exciter control and set for remote operation, the mode, channel enable, frequency, peak clipper, pilot carrier, pa power, and key front-panel controls on the exciter do not affect the operation of the exciter. Likewise, with the exciter set for local operation, the corresponding controls on the exciter control do not affect the operation of the exciter. Audio controls, signals, and monitors of the exciter and exciter control remain enabled whether being operated remotely or locally.

This section of the instruction book contains instructions for operating the HF-8014( ) Exciter. The operator should be aware of several general characteristics of the exciter and exciter control when operating the exciter. Refer to paragraph 4.3 for this information.

Note that channels B1, A2, and B2 if and audio circuits are active only in ISB (independent sideband) mode. In ISB operation, channel A1 output signals are USB (upper sideband), channel B1 output signals are LSB (lower sideband), channel A2 output signals are UUSB (upper-upper sideband), and channel B2 output signals are LLSB (lower-lower sideband). In CW and AM modes, only channel A1 circuits are active.

## 2. CONTROLS AND INDICATORS

Controls and indicators of the HF-8014( ) Exciter are shown in figure 1 and are listed in table 1 along with their function. All controls and indicators listed are applicable to all units unless otherwise indicated.

## 3. OPERATING PROCEDURES

### 3.1 Audio Adjustments

**Note**

Microphone and line audio inputs to the HF-8014( ) Exciter pass through compression amplifiers that level out short-term audio variations to maintain a more constant rf output. The microphone compressor has a relatively short decay time that is desirable for voice signals. The line input amplifiers have longer decay times and will not degrade performance of FSK keyers, multitone data modems, etc, that may be used with the exciters.

Line audio input and microphone level input levels of the HF-8014( ) Exciter may be adjusted by a qualified operator when his application requires it. The audio adjustments are shown in figure 2 and listed in table 2. Refer to maintenance section paragraph 4 for audio input adjustment procedures.

### 3.2 Normal (Local) Operating Procedures

#### 3.2.1 General

When power is turned on or restored, it is normal for the EXCITER FAULT indicator to light. This is caused by latching the exciter fault circuit when power interruptions are detected. The EXCITER FAULT is cleared by changing one of the frequency digits on the exciter.

During a tune cycle, the power amplifier latches the system key line until tuning is complete. This is indicated by the KEY display on the exciter front panel.

During its tune cycle, the HF-8014( ) Exciter supplied a carrier level corresponding to half output power. When the power amplifier and antenna coupler have completed their tune cycles and are ready for normal operation, the PA READY indicator on the exciter front-panel lights. If an antenna coupler is not used,

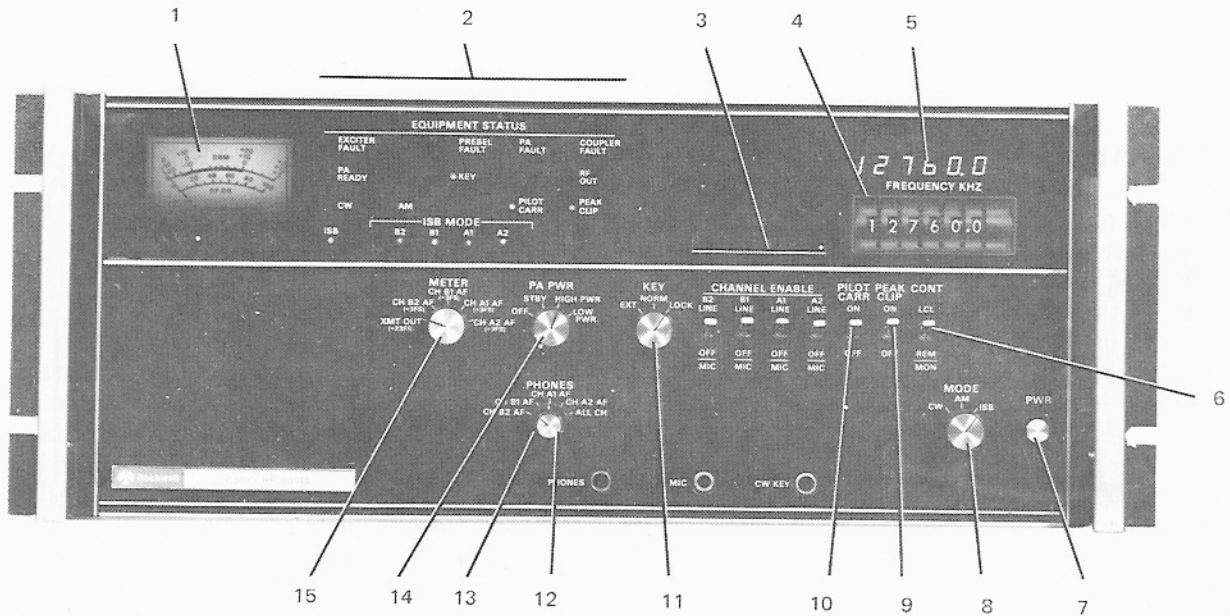

FRONT PANEL

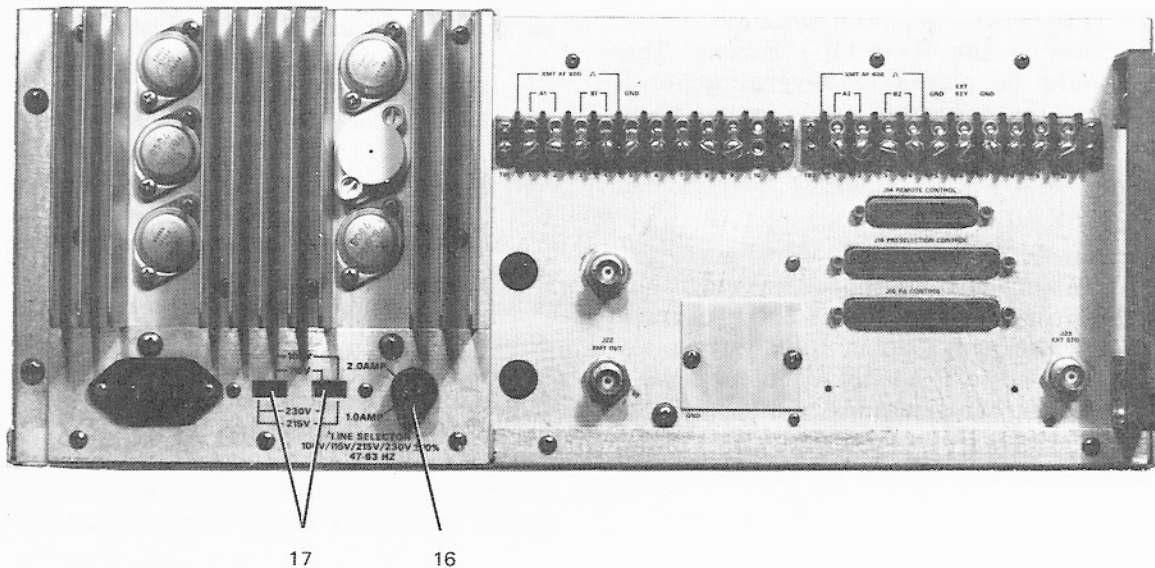

REAR PANEL

TPA-2783-017

HF-8014( ) Exciter, Controls and Indicators  
Figure 1

## description

### 1. GENERAL

The HF-8014/8014A Exciter provides an rf output for AM (AME), CW, and 4-channel ISB signals over the frequency range of 1.600 to 29.9999 MHz in 100-Hz steps. The HF-8014 Exciter is locally controlled from its front panel, but the HF-8014A Exciter may be locally controlled from its front panel or remotely controlled using a compatible control/processor. Options available can provide 10-Hz tuning, internal high-stability frequency reference (oven standard), external frequency standard adapter, and frequency display. An additional option can provide control of the HF-8014 Exciter.

Transmit audio signals can be applied at the rear panel 600-ohm inputs or a front panel microphone input. The CHANNEL ENABLE switches must be used to select the audio source. Front panel displays show the condition of the exciter and associated power amplifier, preselector, and/or coupler.

Remote control of the HF-8014A Exciter is provided by FSK, RS-232C, or MIL-STD-188C data signals. The signaling method is changed by changing strapped

clips on serial interface card A13. As many as 16 HF-8014A Exciters can operate in parallel when using the HF-8093 Exciter Control. Up to 32 HF-8014A Exciters can operate in parallel when using a processor. For multiple exciter operation from one control or processor, RS-232C or MIL-STD-188C data signaling must be used.

The exciter can be mounted in a standard 483-mm (19-in) rack using an optional slide-mounting kit. It can also be mounted in a desk-top enclosure or in a console-style equipment cabinet.

The exciter can be operated from a 100-, 115-, 215-, or 230-V ac, 47- to 420-Hz power source.

### 2. EQUIPMENT SUPPLIED/CONFIGURATION

Equipment supplied in the HF-8014( ) Exciter and its configuration is listed in table 1.

### 3. ASSOCIATED EQUIPMENT

Associated equipment required for operation but not supplied as a part of the HF-8014( ) is listed in table 2.

*Table 1. Equipment Supplied/Configuration.*

SUBASSEMBLY/CIRCUIT CARD		EXCITER		DESCRIPTION/FUNCTION
TITLE	PART NUMBER	HF-8014 622-3472-001	HF-8014A 622-3473-001	
Main chassis	634-8177-001	X	X	
Bottom cover	634-8179-001	X	X	
Top cover	634-8180-002	X	X	
Rear panel	635-9611-003	X	X	
Wiring harness	642-2408-001	X	X	Interconnects TB1.
Wiring harness	642-2407-001	X	X	Interconnects TB2.

Table 1. Equipment Supplied/Configuration (Cont).

SUBASSEMBLY/CIRCUIT CARD		EXCITER		DESCRIPTION/FUNCTION
TITLE	PART NUMBER	HF-8014 622-3472-001	HF-8014A 622-3473-001	
Rf cable assembly, 450-kHz if	642-2454-001	X	X	Interconnects J50, J51, J52, and J53 (450-kHz if from channel A if).
Rf cable assembly J22/J26	637-1525-004	X	X	Interconnects J22 and J26 (xmt output).
Rf cable assembly J27/J36	637-1526-003	X	X	Interconnects J27 and J36 (9.45-MHz output).
Power supply A1	635-9649-001	X	X	Input can be switched for 100, 115, 215, or 230 V ac (47 to 420 Hz).
Front panel assembly A2	634-8199-001	X	X	100-Hz tuning
	634-8199-002			100-Hz tuning, with frequency display
LED status display A2A1	634-0825-013	X	X	
Switch mounting board A2A2	638-6597-001	X	X	
Frequency switchboard A2A3	635-0830-001	X	X	
Frequency display A2A5	637-1781-006			
Transmit audio A3 (A2-B2)	638-6476-003	X	X	Same as 638-6476-001 except MIC select circuits removed.
Transmit audio A4 (A1-B1)	638-6476-001	X	X	
Channel B2 if A5	638-6636-003	X	X	Includes 2.85-kHz LLSB if filter (channel B2).
Channel A2 if A6	638-6636-002	X	X	Includes 2.85-kHz UUSB if filter (channel A2).
Channel B1 if A7	638-6636-001	X	X	Includes 2.85-kHz LSB if filter (channel B1).
Channel A1 if A8	638-6659-001	X	X	Includes 2.85-kHz USB if filter (channel A1).
Rf translator A9	637-1768-002	X	X	Broadband, high performance.
Control A10	638-6622-001	X	X	
Parallel input A11	642-3135-001		X	
Parallel output A12	642-3137-001		X	



Table 1. HF-8014( ) Exciter. Controls and Indicators.

INDEX NUMBER	CONTROL OR INDICATOR	FUNCTION
1	Meter A2M1	Indicates levels as selected by METER switch A2S1.
2	<p>EQUIPMENT STATUS indicators (color)</p> <p>RF OUT A2A1DS1 (yellow)</p> <p>PA READY A2A1DS2 (yellow)</p> <p>PA FAULT A2A1DS3 (red)</p> <p>KEY A2A1DS4 (yellow)</p> <p>EXCITER FAULT A2A1DS5 (red)</p> <p>COUPLER FAULT A2A1DS8 (red)</p> <p>AM A2A1DS9 (yellow)</p> <p>CW A2A1DS10 (yellow)</p> <p>PEAK CLIP A2A1DS11 (yellow)</p> <p>PILOT CARR A2A1DS13 (yellow)</p> <p>ISB A2A1DS14 (yellow)</p> <p>ISB MODE indicators</p> <p>B1 A2A1DS15 (yellow)</p> <p>A1 A2A1DS16 (yellow)</p> <p>B2 A2A1DS18 (yellow)</p> <p>A2 A2A1DS19 (yellow)</p> <p>PRESEL FAULT A2A1DS23 (red)</p>	<p>Indicates that associated pa has an rf output. Indicated by a sidetone enable signal from associated power amplifier.</p> <p>Indicates the associated pa is ready for rf transmission. Indicated by a pa ready signal from associated power amplifier.</p> <p>Indicates pa fault. Indicated by a pa fault signal from associated power amplifier.</p> <p>Indicates key signal applied to exciter key circuits.</p> <p>Indicates power supply low voltage or synthesizer fault. Indicated when power supply fault signal is supplied by power supply A1, synthesizer fault signal is supplied by synthesizer voltage regulator A14, synthesizer subcarrier fault signal is supplied by synthesizer subcarrier generator A15, and/or synthesizer reference fault signal is supplied by synthesizer reference A16. (Synthesizer fault signal from synthesizer voltage regulator A14 is a summary of all synthesizer loss-of-lock signals supplied by A16 through A23.)</p> <p>Indicates a coupler fault. Indicated by a coupler fault signal from associated coupler.</p> <p>Indicates that AM operating mode is selected.</p> <p>Indicates that CW operating mode is selected.</p> <p>Indicates that the if peak clipper circuit is enabled.</p> <p>Indicates that the pilot carrier is enabled.</p> <p>Indicates that ISB operating mode is selected.</p> <p>Indicates that B1 (LSB) transmit circuits are enabled.</p> <p>Indicates that A1 (USB) transmit circuits are enabled.</p> <p>Indicates that B2 (LLSB) transmit circuits are enabled.</p> <p>Indicates that A2 (UUSB) transmit circuits are enabled.</p> <p>Indicates a preselector fault. Indicated by a preselector fault signal from associated preselector.</p>

Table 1. HF-8014( ) Exciter, Controls and Indicators (Cont).

INDEX NUMBER	CONTROL OR INDICATOR	FUNCTION
3	CHANNEL ENABLE switches A2S4 thru A2S7	<p>3-position switches that select the source of the transmit audio input signal when the MODE switch A2S10 is in the ISB position.</p> <ul style="list-style-type: none"> <li>a. B2 (LLSB) enable switch A2S4 selects either LINE, OFF, or MIC. In LINE position, selects the rear-panel line audio input. In MIC position, selects the front-panel microphone input. In OFF position, disables the audio inputs.</li> <li>b. B1 (LSB) enable switch A2S5 selects either LINE, OFF, or MIC. In LINE position, selects the rear-panel line audio input. In MIC position, selects the front-panel microphone input. In OFF position, disables the audio inputs.</li> <li>c. A1 (USB) enable switch A2S6 selects either LINE, OFF, or MIC. In LINE position, selects the rear-panel line audio input. In MIC position, selects the front-panel microphone input. In OFF position, disables the audio inputs.</li> <li>d. A2 (UUSB) enable switch A2S7 selects either LINE, OFF, or MIC. In LINE position, selects the rear-panel line audio input. In MIC position, selects the front-panel microphone input. In OFF position, disables the audio inputs.</li> </ul>
4	FREQUENCY KHZ controls A2S17A thru A2S17G	<p>Sets bcd frequency control signal as indicated by thumb-wheel display.</p> <ul style="list-style-type: none"> <li>a. A2S17A selects tens megahertz.</li> <li>b. A2S17B selects ones megahertz.</li> <li>c. A2S17C selects hundreds kilohertz.</li> <li>d. A2S17D selects tens kilohertz.</li> <li>e. A2S17E selects ones kilohertz.</li> <li>f. A2S17F selects hundreds hertz.</li> <li>g. A2S17G selects tens hertz (option).</li> </ul>
5	FREQUENCY KHZ display A2A5U20 thru A2A5U26 (used with frequency display option only)	<p>Displays bcd frequency control signal as set by FREQUENCY KHZ controls or a remote exciter.</p> <ul style="list-style-type: none"> <li>a. A2A5U20 displays tens megahertz.</li> <li>b. A2A5U21 displays ones megahertz.</li> <li>c. A2A5U22 displays hundreds kilohertz.</li> <li>d. A2A5U23 displays tens kilohertz.</li> <li>e. A2A5U24 displays ones kilohertz.</li> </ul>
(Cont)		<ul style="list-style-type: none"> <li>f. A2A5U25 displays hundreds hertz.</li> </ul>

Table 1. HF-8014( ) Exciter, Controls and Indicators (Cont).

INDEX NUMBER	CONTROL OR INDICATOR	FUNCTION
5 (Cont)		<p>g. A2A5U26 displays tens hertz (option).</p> <p>h. A2A5U27 displays ones hertz (option).</p>
6	CONT switch A2S12	<p>Selects use and method of controlling the exciter.</p> <p>a. LCL position allows exciter to be controlled locally. (HF-8014 Exciter must be kept in LCL position for operation.)</p> <p>b. REM position allows exciter to be controlled remotely. REM position disables local control of mode, frequency, pilot carrier, peak clip, pa power, and key signals. Local audio controls, signals, and monitors remain enabled.</p> <p>c. MON position is a momentary position that enables local controls and sets the monitor bit (word 4, character 5, bit 1) of the exciter control monitor response. This may be used, for example, to command a processor control to modify a stored preset table of operating frequency and mode information to that set on the local controls.</p>
7	PWR switch A2S15	<p>Set power on/off. When pressed and latched (inward position), power is applied to the exciter. When pressed and unlatched (outward position), power is removed from the exciter.</p>
8	MODE switch A2S10	<p>Selects exciter operating mode and bandwidth.</p> <p>a. CW position selects CW mode and if attenuator pad (16-kHz bandwidth).</p> <p>b. AM position selects AM mode and channel A1 bandpass filter (2.85-kHz bandwidth).</p> <p>c. ISB position selects ISB mode and UUSB, USB, LLSB, and LSB bandpass filters (2.85-kHz bandwidth filters).</p>
9	PEAK CLIP switch A2S9	<p>Controls the if amplifier peak clipper. In the ON position, peak clipper circuit is enabled. In the OFF position, peak clipper circuit is disabled.</p> <p style="text-align: center;"><b>Note</b></p> <p>The peak clipper circuit on channel A1 if A8 is switched in and out by means of the front-panel switch. The clipper may be set to provide clipping of the if frequency over 0- to 12-dB range.</p>
10	PILOT CARR switch A2S8	<p>Controls pilot carrier enable signal. In the ON position, pilot carrier is enabled. In the OFF position, pilot carrier is disabled.</p>

Table 1. HF-8014( ) Exciter, Controls and Indicators (Cont).

INDEX NUMBER	CONTROL OR INDICATOR	FUNCTION
11	KEY switch A2S3	<p>Selects the method for applying a key signal.</p> <ul style="list-style-type: none"> <li>a. EXT position allows an external key (ground or +6 V dc) to be applied at the EXT KEY or EXT KEY (+6 V) terminals on the exciter rear panel.</li> <li>b. NORM position allows an external key (ground) to be applied at CW KEY jack (J1) or MIC jack (J3) on the exciter front panel.</li> <li>c. LOCK position applies a fixed key signal.</li> </ul>
12	PHONES (⊙) level control A2R13	<p>Controls headphone volume; full clockwise equals maximum volume.</p>
13	PHONES switch A2S11	<p>Selects audio to be monitored at the PHONES jack (J2) on the exciter front panel.</p> <ul style="list-style-type: none"> <li>a. CH B2 AF position selects channel B2 transmit audio output.</li> <li>b. CH B1 AF position selects channel B1 transmit audio output.</li> <li>c. CH A1 AF position selects channel A1 transmit audio output.</li> <li>d. CH A2 AF position selects channel A2 transmit audio output.</li> <li>e. ALL CHAN position selects transmit audio output of all channels (B2, B1, A1, A2).</li> </ul>
14	PA PWR switch A2S2	<p>Selects pa power control as indicated:</p> <ul style="list-style-type: none"> <li>a. OFF position disables power in associated power amplifier.</li> <li>b. STBY (standby) position enables low-voltage circuit in the associated power amplifier. (Power amplifier cannot be keyed in this position.)</li> <li>c. HIGH PWR position enables low-voltage and high-voltage circuits in the associated power amplifier and allows high-power transmissions from the power amplifier when it was keyed.</li> <li>d. LOW PWR position enables low-voltage and high-voltage circuits in the associated power amplifier and signals the power amplifier to operate in low-power mode when it is keyed.</li> </ul>
15	METER switch A2S1	<p>Selects signal levels to be measured by meter A2M1. Selectable positions are as follows:</p> <ul style="list-style-type: none"> <li>a. XMT OUT (+23FS) position monitors transmit rf signal output from exciter (indicates +23 dB mW full scale).</li> </ul>
(Cont)		

Table 1. HF-8014( ) Exciter, Controls and Indicators (Cont).

INDEX NUMBER	CONTROL OR INDICATOR	FUNCTION
15 (Cont)		<p>b. CH B2 AF (+3FS) position monitors channel B2 transmit audio output (indicates if channel B2 transmit audio is in compression range, black segment on meter).</p> <p>c. CH B1 AF (+3FS) position monitors channel B1 transmit audio output (indicates if channel B1 transmit audio is in compression range, black segment on meter).</p> <p>d. CH A1 AF (+3FS) position monitors channel A1 transmit audio output (indicates if channel A1 transmit audio is in compression range, black segment on meter).</p> <p>e. CH A2 AF (+3FS) position monitors channel A2 transmit audio output (indicates if channel A2 transmit audio is in compression range, black segment on meter).</p>
16	Fuse A1F1 (located on rear panel)	Fuse in power line. 2 A used for 100/115-V ac operation, 1 A used for 215/230-V ac operation.
17	Power selection switch A1S1A and A1S1B (located on rear panel)	<p>Controls input power strapping of power transformer in power supply A1.</p> <p>a. In 100-V position, power transformer strapped for 100-V ac operation (90 to 110 V ac).</p> <p>b. In 115-V position, power transformer strapped for 115-V ac operation (103 to 127 V ac).</p> <p>c. In 215-V position, power transformer strapped for 215-V ac operation (193 to 237 V ac).</p> <p>d. In 230-V position, power transformer strapped for 230-V ac operation (207 to 253 V ac).</p>

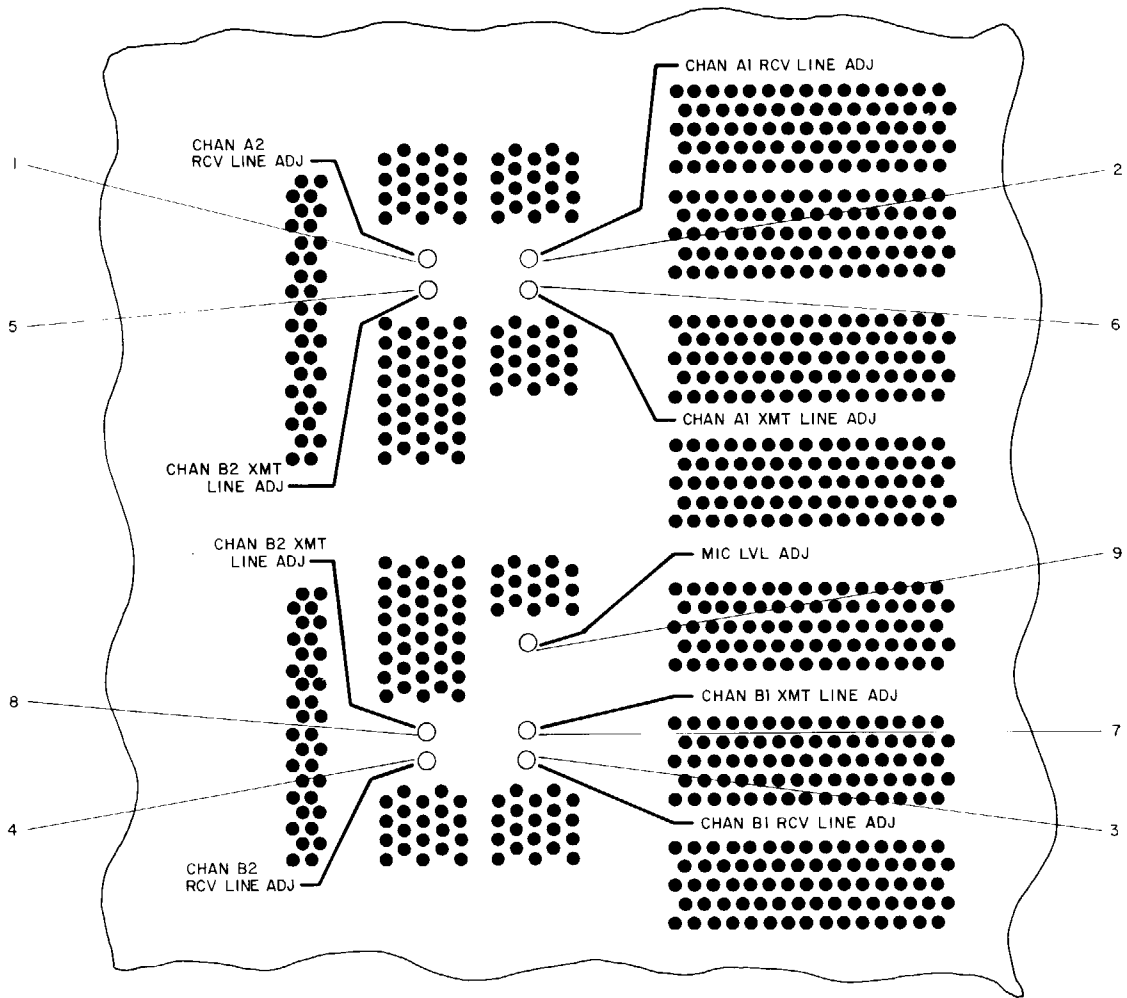

TPA-2719-014

Top Cover Adjustments  
Figure 2

Table 2. Line Audio Adjustments.

INDEX NUMBER	ADJUSTMENT	PURPOSE
<div style="border: 1px solid black; display: inline-block; padding: 2px;">Note</div> XMT LINE ADJ controls allow for an adjustable compression characteristic of the line audio input amplifier. Line audio input can be adjusted for a -26-dB mW up to +10-dB mW compression threshold.		
1 thru 4		Receiver (not used in HF-8014( ) exciter).
5	CH B2 XMT LINE ADJ A3R130 (accessible through top cover)	Controls channel B2 transmit line audio input. Normally adjusted with a 1000-Hz, -15-dB mW input to just start audio compression (compression threshold).
6	CH B1 XMT LINE ADJ A4R130 (accessible through top cover)	Controls channel B1 transmit line audio input. Normally adjusted with a 1000-Hz, -15-dB mW input to just start audio compression (compression threshold).
7	CH A1 XMT LINE ADJ A4R53 (accessible through top cover)	Controls channel A1 transmit line audio input. Normally adjusted with a 1000-Hz, -15-dB mW input to just start audio compression (compression threshold).
8	CH A2 XMT LINE ADJ A3R53 (accessible through top cover)	Controls channel A2 transmit line audio input. Normally adjusted with a 1000-Hz, -15-dB mW input to just start audio compression (compression threshold).
9	MIC LVL ADJ A4R1 (accessible through top cover)	Controls microphone input compression threshold. Normally adjusted with a 1000-Hz, -55-dB mW MIC input, to just start audio compression (compression threshold).

pa ready is indicated when the pa tune cycle is complete. The RF OUT indicator is lit when the pa has an rf output and is normally lit briefly during the last stages of the tune cycle.

In local control, the exciter can be keyed from a microphone with ptt key (at MIC jack) or a CW key (at CW KEY jack), or a key line applied at the EXT KEY terminals on the rear panel. The EXT KEY inputs (ground or +6 V dc) are used for ptt or CW key, depending on mode selected. The KEY switch A2S3, when set to NORM, allows ptt keying from the microphone in any mode except CW, and CW keying when in CW mode. When the KEY switch is set to EXT KEY, the exciter can be keyed only by applying a key line to the EXT KEY terminals. When the KEY switch is in the LOCK position, the exciter is continuously keyed regardless of mode.

In CW mode, after the key is released, the exciter and power amplifier circuits are held keyed for a short period (0.25 second) with no rf output transmission.

This hang time is adjustable with A10R46 (refer to paragraph 4.4 in the maintenance section for hang time adjustment).

**3.2.2 Turn-On Procedures**

To turn on the HF-8014( ) Exciter locally in any mode with no special options or applications, follow the procedures outlined below:

- a. Set KEY switch to keying method to be used.
- b. Connect the appropriate keying device.
- c. Set CONT switch to LCL position.
- d. Set PWR switch on (pressed and latched inward).
- e. Clear the exciter fault by changing a frequency digit.
- f. Set PA PWR switch to STBY position. Allow a warmup time as required by associated power amplifier before continuing operation.
- g. Refer to mode operating procedures to perform normal operations.

### 3.2.3 CW Operation

To operate the HF-8014( ) Exciter in the CW mode with no special options or applications, follow the procedures outlined below:

- a. Perform turn-on procedures in paragraph 3.2.2.
- b. Set MODE switch to CW mode.
- c. Set FREQUENCY KHZ thumb-wheel controls to desired operating frequency.

**Note**

The HF-8014( ) Exciter provides CW (A1) operation, which means the carrier is switched on and off. A receiver equipped to receive CW (A1) has a bfo or a similar means of detecting a transmitted CW carrier. If your receiver is not equipped to receive a transmitted CW carrier signal, the receiver must be offset from the operating frequency to generate a received CW audio signal. Your receiver instruction book should indicate how to set up to receive CW (A1) signals.

- d. Set KEY switch to NORM if using front panel CW KEY jack J2 or to EXT KEY if using rear panel EXT KEY inputs.
- e. Momentarily apply key and allow unit to tune.
- f. When tuning is complete, normal CW communication can be established. Monitor CW sidetone by connecting headphones to PHONES jack J1 on front panel, with PHONES switch in CH A1 position.

### 3.2.4 AM Operation

To operate the HF-8014( ) Exciter in the AM mode with no special options or applications, follow the procedures outlined below:

- a. Perform turn-on procedures in paragraph 3.2.2.
- b. Set MODE switch to AM mode.
- c. Set FREQUENCY KHZ thumb-wheel controls to desired operating frequency.
- d. Set KEY switch to NORM if using front panel MIC jack J3 or to EXT KEY if using rear panel EXT KEY inputs.
- e. Momentarily apply key and allow unit to tune.
- f. When tuning is complete, set CH A1 CHANNEL ENABLE to MIC if jack J3 is to be used, or set switch to LINE if line audio input is to be used.

### 3.2.5 ISB Operation

To operate the HF-8014( ) Exciter in the ISB mode with no special options or applications, follow the procedures outlined below:

- a. Perform turn-on procedures in paragraph 3.2.2.
- b. Set MODE switch to ISB mode.
- c. Set FREQUENCY KHZ thumb-wheel controls to desired operating frequency.
- d. Set KEY switch to EXT KEY if using rear panel EXT KEY inputs or to NORM if using front-panel MIC jack.
- e. Ensure that the desired channel A1, A2, B1, and B2 audio inputs are properly connected.
- f. Momentarily apply key and allow unit to tune.
- g. When tuning is complete, normal ISB voice and/or data audio communications can be established. Set CHANNEL ENABLE switches to MIC or LINE depending on the source of the audio signal.

## 3.3 Fault Clearing Procedures

### 3.3.1 Exciter Fault

When lit, the EXCITER FAULT indicator shows that one of the following occurred in the exciter: (1) frequency synthesizer loss of lock, (2) a loss of power supply output voltage, either through an associated short circuit or power supply failure, or (3) a momentary loss of primary power.

If exciter fault is caused by frequency synthesizer loss of lock, EXCITER FAULT indicator will go out when lock is restored.

If exciter fault is caused by a loss of power supply voltage, the fault/failure must first be corrected. After removal of the fault/failure, a frequency digit on the front-panel control must be changed to clear the fault.

If exciter fault is caused by a momentary loss of primary power, changing any frequency digit on the front-panel controls will clear the fault.

If the exciter fault cannot be cleared, refer to testing and troubleshooting procedures in the maintenance section of this instruction book.

### 3.3.2 PA Fault

When lit, the PA FAULT indicator shows that one of the following occurred in the associated power amplifier: (1) short-term transient condition or loss of power, (2) long-term loss of power, or (3) failure in the power amplifier.

If pa fault is caused by a transient condition or loss of power, it can be cleared by initiating a new tune cycle. Change any front-panel frequency digit to initiate a



new tune cycle. Note, however, a long-term loss of power may require the associated power amplifier to go through a complete warmup cycle before returning.

If the pa fault cannot be cleared, refer to testing and troubleshooting procedures in the maintenance section of the power amplifier instruction book.

### **3.3.3 Coupler Fault**

When lit, the COUPLER FAULT indicator shows that one of the following occurred in the associated antenna coupler: (1) transient condition or loss of power or (2) failure in the antenna coupler.

If coupler fault is caused by a transient condition or loss of power, it can be cleared by initiating a new tune cycle. Change any front-panel frequency digit to initiate a new tune cycle.

If the coupler fault cannot be cleared, refer to testing and troubleshooting procedures in the maintenance section of the antenna coupler instruction book.

### **3.3.4 Preselector Fault**

When lit, the PRESEL FAULT indicator shows that one of the following occurred in the associated preselector: (1) transient condition or loss of power or (2) failure in the preselector tuning or power supply.

If the preselector fault is caused by a transient condition or loss of power, it can be cleared by initiating a new tune cycle.

If the preselector fault cannot be cleared, refer to testing and troubleshooting procedures in the maintenance section of the preselector instruction book).

### **3.3.5 System Fault With Lockout**

This paragraph applies only to exciters with system fault lockout option. If a pa fault, coupler fault, or preselector fault occurs three times in succession without clearing on a frequency change, the tune start is locked out (fixed logic 1) and a tune cycle cannot be initiated until lockout is cleared.

To clear tune start lockout, exciter power must be removed and restored. This resets the tune start lockout counter and will permit three more successive tries.

A system fault summary indication (logic 1, fault) is provided on the rear panel of the HF-8014( ) Exciter (TB1-6).

## **4. REMOTE OPERATION (HF-8014A ONLY)**

### **4.1 General**

To operate the HF-8014A Exciter from an HF-8093 Exciter Control or a processor, the CONT switch on the exciter is set to the REM position. This transfers control to the remote control device except for audio monitoring. The local operator is still able to monitor exciter rf level and transmit audio signals, using the exciter front-panel meter and controls.

The MON position on the exciter CONT switch sets the exciter to local control and sets the monitor bit in the monitor data. This can be used, as an example, to set the exciter front-panel data into a preset table in a processor. The MON position has no function when used with the HF-8093 Exciter Control.

### **4.2 Operating Procedures Using the HF-8093 Exciter Control**

With the exception of setting the HF-8093 Exciter Control CONT switch to the NORM position and the HF-8014A Exciter CONT switch to the REM position, operating procedures for the exciter control are identical to operating the local exciter (paragraph 3.2). When in remote operation, the EXCITER FAULT is cleared by changing a frequency digit on the HF-8093 Exciter Control front panel.

The following paragraphs contain the operating characteristics of the HF-8093 Exciter Control and are given for information only.

## **4.3 OPERATING CHARACTERISTICS**

### **4.3.1 Power Failure and Initialization**

When primary power to the HF-8093 Exciter Control is initially applied, or reapplied after a power interruption, the exciter control transmits all command information and requests monitor information from the addressed HF-8014A Exciter. When primary power is applied to an exciter, after power has been applied to the exciter control, the exciter control again transmits all command information from the front-panel control settings and requests updated status from the addressed exciter. When power is applied or restored in a system containing more than one exciter, the exciter control can initialize only the

currently addressed exciter. The remaining exciters must be initialized manually, one at a time, by selecting the appropriate address and transmitting the desired operating parameters.

#### **4.3.2 CONT Switch Operation**

The user must be aware that if the exciter control front-panel controls are changed while the CONT switch is in the TEST mode, their settings may no longer correspond to the exciter operating conditions. Consequently, when the next command to the exciter is initiated (in the NORM mode), some of these settings may be transmitted to the exciter, causing it to change its operating conditions to correspond to the control settings.

The NORM position of the CONT switch is used for normal remote control operation. The TEST position is used to verify that the exciter control is operational and that it can communicate with itself internally. In the TEST MODE, the data from the exciter control is transmitted directly to its own display unit. Frequency information displayed will follow the positioning of the frequency thumb-wheel switches; the mode, key, pa power, pilot carrier, peak clipper, and channel enable indicators will follow positioning of their front panel controls. When the CONT switch is returned to the NORM position, the exciter control automatically updates to the status information from the exciter without changing the operating conditions of the exciter.

In the TEST mode, the flashing fault indicator (paragraph 4.3.5) is a normal indication. The flashing may become erratic or halt momentarily as front-panel controls are operated.

#### **4.3.3 Address Selection**

The HF-8093 Exciter Control communicates with only one at a time of up to 16 HF-8014A Exciters being controlled. The ADDRESS switch contains numbers from 0 through 15 corresponding to binary coding of the four address bits of the data words.

When the ADDRESS switch is rotated to an address, the exciter control automatically requests a complete status update from the addressed exciter. This is done by transmitting an abbreviated 2-character status request only for words 1, 2, 3, and 4. The exciter control status and frequency displays then update with the operating conditions of the newly addressed exciter.

No command transmission will be initiated from the exciter control to the newly addressed exciter until

changes are made to the front-panel control settings of the exciter control. Thus the operating status of the exciter will remain unchanged. This sequence of operation permits an operator to address an exciter solely for the purpose of current status inspection or verification.

#### **4.3.4 BUSY Indicator Operation**

The BUSY indicator on the HF-8093 Exciter Control front panel is lit whenever the addressed HF-8014A Exciter CONT switch is placed in the LCL position. When this indicator is lit, the exciter control automatically and continuously requests words 1, 2, 3, and 4 monitor data from the exciter. This continuously updates all status information to the exciter control. The operator is thus alerted to the current status of the addressed exciter while it is being locally controlled at the remote site. As long as the BUSY indicator remains lit, commands from the exciter control to the addressed exciter are inhibited.

When the exciter is again returned to remote operation (CONT to REM), the BUSY indicator turns off and the exciter control transmits all current front-panel switch and control settings to the addressed exciter. This causes the exciter operational status to revert to the conditions currently selected on the exciter control front panel.

#### **4.3.5 No Indication of Monitor Response**

If for any reason the HF-8093 Exciter Control fails to receive monitor data transmissions from the addressed HF-8014A Exciter (data transmission line inoperative, unit inoperative, unit power disabled, addressed unit does not exist, etc), the exciter fault indicator (EXCITER FAULT) will flash at approximately a 0.25-Hz rate (2 seconds on, 2 seconds off). Flashing is normal, however, when the front-panel CONT switch is in the TEST position.

#### **4.3.6 Polling Operation**

The polling strapping option discussed in the exciter control installation section permits the exciter control to function in a polling mode of operation. This mode of operation is intended for use when an auxiliary system status display is used to display the current status of more than one remote exciter.

In the polling mode of operation, the exciter control automatically and sequentially requests status data from all 16 possible remote addresses. As status data is received from each addressed remote exciter, it is

then transmitted by the exciter control, on the common system control bus, to a remote status display board for update of the display. The remote status display board must be connected to the system control bus to receive the updated display information. If no status response is received from a polled unit, no status data is transmitted to the status display board by the exciter control.

Since the status display board connects to the common system control bus, it is programmed to recognize its own unique address, and the exciter control is programmed to use this same address (00000 for ADB5 through ADB1) when communicating with the status display board. Therefore, when using the polling capability along with a remote status display board and the 8-bit character data format, only 15 of the 16 address combinations are available for remote exciter assignment, since the display board itself requires one of the addresses. If, however, the 7-bit ASCII character data format is used in the system, all 16 remote exciter addresses are available for use because the address assigned to the status display board is not among the 16 addresses (of the 32 possible in this format) controlled by the thumb-wheel address selector switch of the exciter control.

**4.3.7 Control and Monitor Data Transmission**

Under normal operating conditions, the HF-8093 Exciter Control transmits control information to the addressed HF-8014A Exciter only upon initiation from the front-panel controls.

Operation of the frequency thumb-wheel switches initiates transmission of a frequency control word (word 1), along with a request for a frequency status

response from the exciter. Likewise, operation of any of the front-panel remote-function switches initiates control transmission, with monitor request, of the corresponding word for which the function is defined. When no control word transmission is pending, the exciter control reverts to its idle state.

In the idle state, the exciter control continuously transmits the 2-character, word 4 monitor request. This keeps the front-panel status indicators up to date on any of the word 4 monitor status information (such as the various fault bits) that may change dynamically during normal operation of the remote unit. Monitor word transmission from an exciter is transmitted only when requested by the exciter control.

The data transmitted and received on the control and monitor buses is serial, asynchronous, and is organized in groups of characters called words. The format is independent of the type of signaling (FSK, RS-232C, or MIL-STD-188C) used. The data formats are user-selected by internal strapping. One format uses 7-bit ASCII coded characters and is described in paragraphs 4.3.7.1 and 4.3.7.2. The other format uses an 8-bit character code and is described in paragraphs 4.3.7.3 and 4.3.7.4. Regardless of the format selected, there are four control words and four monitor data words used by the exciter control.

**4.3.7.1 ASCII Word Format**

A word consists of 3 special nonfunctional characters that are used to establish word boundaries, and 11 functional characters that contain address and front-panel control/status information. Refer to figure 3.

ASCII WORD FORMAT														
SPECIAL NON-FUNCTIONAL CHARACTERS		FUNCTIONAL CHARACTERS											SPECIAL NON-FUNCTIONAL CHARACTERS	
#	#	#	#	#	#	#	#	#	#	#	#	#	#	#
1	2	1	2	3	4	5	6	7	8	9	10	11	3	

TPA - 2855 - 011

ASCII Word Format  
Figure 3

The three special nonfunctional characters are selected from carriage return (CR), line feed (LF), execute (X), hyphen (-), and dollar sign (\$). Refer to figures 4 and 5. CR and LF are the first two special nonfunctional characters of each ASCII control word and execute (X) ends each of the ASCII control words. The hyphen (-) is the first two special nonfunctional characters of each ASCII monitor word, and the dollar sign (\$) is used to end each of the monitor words.

The eleven functional characters of the control and monitor words consist of two address characters, one sequence designator, and eight characters for control/status information.

The control and monitor data word formats are similar with one exception, control word 4 is shortened to seven ASCII characters in order to transmit key information as fast as possible. Monitor word 4 contains all eleven ASCII characters. The first five characters of each word are organized the same: two nonfunctional characters are used to establish synchronization, the first two functional characters establish the address, and the third functional character serves as the sequence designator. As many as 32 units (00 through 31) can be addressed on one control or monitor bus, using bcd-coded combinations of the two address characters. Five binary-coded address lines with internal pullup to logic 1 are available at the remote control connector of the HF-8014A Exciter and may be strapped to any combination. However, in the HF-8093 Exciter Control, only four of the five address bits are controlled by the address selector thumb-wheel switch (ADB5 is not used),

limiting the number of addresses to 16 (00 through 15). Table 3 describes the relationship between address line strapping (ADB4 through ADB1), the corresponding bcd address digits, and the remote control address selector. Only X's require strapping to ground in the exciter; the dashes remain unstrapped or open address lines.

The third functional ASCII character in each word is the sequence designator. Refer to table 4. The sequence designator is used to define the word number and type (control only, control with status request, or status request only) of the word represented.

Data rates are switchable on the serial interface card A13 from 75 to 19 200 bauds. The levels are strapable for either RS-232C (+6-V dc level defined as a logic 0) or MIL-STD-188C (+6-V dc level defined as a logic 1) compatibility. Refer to paragraph 3.1 of the installation section for switching and strapping instructions.

#### **4.3.7.2 ASCII Character Format**

The special nonfunctional ASCII characters are used as word boundary delimiters for each of the control and monitor words. The nonfunctional characters are encoded/decoded in terms of a 7-bit code shown in table 5.

The functional characters contain the control and monitor data and are encoded/decoded in terms of a 4-bit code also shown in table 5. A logic 1 selects or enables a function, while a logic 0 disables a function.

CHARACTER SIGNIFICANCE		ASCII PRINT CHARS	FUNCTIONAL BIT CODING																						
			WT 8	WT 4	WT 2	WT 1																			
<table border="1"> <tr> <td>CR</td><td>LF</td><td>A1</td><td>A2</td><td>SD</td><td>F1</td><td>F2</td><td>F3</td><td>F4</td><td>F5</td><td>F6</td><td>F7</td><td>F8</td><td>X</td> </tr> </table>		CR	LF	A1	A2	SD	F1	F2	F3	F4	F5	F6	F7	F8	X	WORD 1 CHARACTER SEQUENCE									
CR	LF	A1	A2	SD	F1	F2	F3	F4	F5	F6	F7	F8	X												
CR	CARRIAGE RETURN	CR	NA	NA	NA	NA	NA	NA	NA	NA	NA	NA	NA												
LF	LINE FEED	LF	NA	NA	NA	NA	NA	NA	NA	NA	NA	NA	NA												
A1	ADDRESS, M.S.D. (BCD)	0-3	0	0	A1(2)	A1(1)	0	0	A1(2)	A1(1)	0	0	A1(1)												
A2	ADDRESS, L.S.D. (BCD)	0-9	A2(8)	A2(4)	A2(2)	A2(1)	0	0	A2(2)	A2(1)	0	0	A2(1)												
SD	SEQUENCE DESIGNATOR	0,1,2	NA	NA	NA	NA	0	0	NA	NA	0	0	NA												
F1	FREQUENCY - 10 MHz (BCD)	0,1,2	0	0	10 MHz (2)	10 MHz (1)	0	0	10 MHz (2)	10 MHz (1)	0	0	10 MHz (1)												
F2	FREQUENCY - 1 MHz (BCD)	0-9	1 MHz (8)	1 MHz (4)	1 MHz (2)	1 MHz (1)	0	0	1 MHz (2)	1 MHz (1)	0	0	1 MHz (1)												
F3	FREQUENCY-100 kHz (BCD)	0-9	100 kHz (8)	100 kHz (4)	100 kHz (2)	100 kHz (1)	0	0	100 kHz (2)	100 kHz (1)	0	0	100 kHz (1)												
F4	FREQUENCY- 10 kHz (BCD)	0-9	10 kHz (8)	10 kHz (4)	10 kHz (2)	10 kHz (1)	0	0	10 kHz (2)	10 kHz (1)	0	0	10 kHz (1)												
F5	FREQUENCY- 1 kHz (BCD)	0-9	1 kHz (8)	1 kHz (4)	1 kHz (2)	1 kHz (1)	0	0	1 kHz (2)	1 kHz (1)	0	0	1 kHz (1)												
F6	FREQUENCY-100 Hz (BCD)	0-9	100 Hz (8)	100 Hz (4)	100 Hz (2)	100 Hz (1)	0	0	100 Hz (2)	100 Hz (1)	0	0	100 Hz (1)												
F7	FREQUENCY- 10 Hz (BCD)	0-9	10 Hz (8)	10 Hz (4)	10 Hz (2)	10 Hz (1)	0	0	10 Hz (2)	10 Hz (1)	0	0	10 Hz (1)												
F8	FREQUENCY- 1 Hz (BCD)	0-9	1 Hz (8)	1 Hz (4)	1 Hz (2)	1 Hz (1)	0	0	1 Hz (2)	1 Hz (1)	0	0	1 Hz (1)												
X	EXECUTE	X	NA	NA	NA	NA	0	0	NA	NA	0	0	NA												
<table border="1"> <tr> <td>CR</td><td>LF</td><td>A1</td><td>A2</td><td>SD</td><td>M1</td><td>M2</td><td>M3</td><td>M4</td><td>M5</td><td>M6</td><td>M7</td><td>M8</td><td>X</td> </tr> </table>		CR	LF	A1	A2	SD	M1	M2	M3	M4	M5	M6	M7	M8	X	WORD 2 CHARACTER SEQUENCE									
CR	LF	A1	A2	SD	M1	M2	M3	M4	M5	M6	M7	M8	X												
CR	CARRIAGE RETURN	CR	NA	NA	NA	NA	NA	NA	NA	NA	NA	NA	NA												
LF	LINE FEED	LF	NA	NA	NA	NA	NA	NA	NA	NA	NA	NA	NA												
A1	ADDRESS, M.S.D. (BCD)	0-3	0	0	A1(2)	A1(1)	0	0	A1(2)	A1(1)	0	0	A1(1)												
A2	ADDRESS, L.S.D. (BCD)	0-9	A2(8)	A2(4)	A2(2)	A2(1)	0	0	A2(2)	A2(1)	0	0	A2(1)												
SD	SEQUENCE DESIGNATOR	4,5,6	NA	NA	NA	NA	0	0	NA	NA	0	0	NA												
M1	RESERVED	0	0	0	0	0	0	0	0	0	0	0	0												
M2	RESERVED	0	0	0	0	0	0	0	0	0	0	0	0												
M3	RESERVED	0	0	0	0	0	0	0	0	0	0	0	0												
M4	RESERVED	0	0	0	0	0	0	0	0	0	0	0	0												
M5	RESERVED	0	0	0	0	0	0	0	0	0	0	0	0												
M6	PEAK CLIPPER ENABLE	0,1	0	0	0	0	0	0	0	0	0	0	PEAK CLIPPER ENABLE												
M7	MODE	0-9, A-F	0	AM ENABLE	CW ENABLE	ISB ENABLE	0	0	AM ENABLE	CW ENABLE	ISB ENABLE	0	0												
M8	ISB CHANNEL ENABLES	0-9, A-F	B2 ENABLE	B1 ENABLE	A1 ENABLE	A2 ENABLE	0	0	B2 ENABLE	B1 ENABLE	A1 ENABLE	A2 ENABLE	0												
X	EXECUTE	X	NA	NA	NA	NA	0	0	NA	NA	0	0	NA												
<table border="1"> <tr> <td>CR</td><td>LF</td><td>A1</td><td>A2</td><td>SD</td><td>V1</td><td>V2</td><td>V3</td><td>V4</td><td>V5</td><td>V6</td><td>V7</td><td>V8</td><td>X</td> </tr> </table>		CR	LF	A1	A2	SD	V1	V2	V3	V4	V5	V6	V7	V8	X	WORD 3 CHARACTER SEQUENCE									
CR	LF	A1	A2	SD	V1	V2	V3	V4	V5	V6	V7	V8	X												
CR	CARRIAGE RETURN	CR	NA	NA	NA	NA	NA	NA	NA	NA	NA	NA	NA												
LF	LINE FEED	LF	NA	NA	NA	NA	NA	NA	NA	NA	NA	NA	NA												
A1	ADDRESS, M.S.D. (BCD)	0-3	0	0	A1(2)	A1(1)	0	0	A1(2)	A1(1)	0	0	A1(1)												
A2	ADDRESS, L.S.D. (BCD)	0-9	A2(8)	A2(4)	A2(2)	A2(1)	0	0	A2(2)	A2(1)	0	0	A2(1)												
SD	SEQUENCE DESIGNATOR	8,9,A	NA	NA	NA	NA	0	0	NA	NA	0	0	NA												
V1	RESERVED	0	0	0	0	0	0	0	0	0	0	0	0												
V2	RESERVED	0	0	0	0	0	0	0	0	0	0	0	0												
V3	RESERVED	0	0	0	0	0	0	0	0	0	0	0	0												
V4	RESERVED	0	0	0	0	0	0	0	0	0	0	0	0												
V5	AUXILIARY	0-9, A-F	-	-	-	-	0	0	-	-	0	0	-												
V6	AUXILIARY	0-9, A-F	-	-	-	-	0	0	-	-	0	0	-												
V7	RESERVED	0	0	0	0	0	0	0	0	0	0	0	0												
V8	PILOT CARRIER/PA CONTROL	0-9, A-F	PILOT CARR ENABLE	PA LO PWR ENABLE	PA HV ENABLE	PA LV ENABLE	0	0	PILOT CARR ENABLE	PA LO PWR ENABLE	PA HV ENABLE	PA LV ENABLE	0												
X	EXECUTE	X	NA	NA	NA	NA	0	0	NA	NA	0	0	NA												
<table border="1"> <tr> <td>CR</td><td>LF</td><td>A1</td><td>A2</td><td>SD</td><td>K1</td><td>X</td> </tr> </table>		CR	LF	A1	A2	SD	K1	X	WORD 4 CHARACTER SEQUENCE																
CR	LF	A1	A2	SD	K1	X																			
CR	CARRIAGE RETURN	CR	NA	NA	NA	NA																			
LF	LINE FEED	LF	NA	NA	NA	NA																			
A1	ADDRESS, M.S.D. (BCD)	0-3	0	0	A1(2)	A1(1)																			
A2	ADDRESS, L.S.D. (BCD)	0-9	A2(8)	A2(4)	A2(2)	A2(1)																			
SD	SEQUENCE DESIGNATOR	C,D,E	NA	NA	NA	NA																			
K1	EXCITER/PA SYSTEM KEY	0,1	0	0	0	SYSTEM KEY																			
X	EXECUTE	X	NA	NA	NA	NA																			

TPA-3014-014

ASCII Character Control Word Format  
Figure 4

CHARACTER SIGNIFICANCE		ASCII PRINT CHARS.	FUNCTIONAL BIT CODING				
			WT 8	WT 4	WT 2	WT 1	
- - A1 A2 SD F1 F2 F3 F4 F5 F6 F7 F8 S			WORD 1 CHARACTER SEQUENCE				
-	HYPHEN		-	NA	NA	NA	NA
-	HYPHEN		-	NA	NA	NA	NA
A1	ADDRESS, M.S.D. (BCD)		0-3	0	0	A1(2)	A1(1)
A2	ADDRESS, L.S.D. (BCD)		0-9	A2(8)	A2(4)	A2(2)	A2(1)
SD	SEQUENCE DESIGNATOR		1	NA	NA	NA	NA
F1	FREQUENCY- 10 MHz (BCD)		0,1,2	0	0	10 MHz (2)	10 MHz (1)
F2	FREQUENCY 1 MHz (BCD)		0-9	1 MHz (8)	1 MHz (4)	1 MHz (2)	1 MHz (1)
F3	FREQUENCY- 100 kHz (BCD)		0-9	100 kHz (8)	100 kHz (4)	100 kHz (2)	100 kHz (1)
F4	FREQUENCY- 10 kHz (BCD)		0-9	10 kHz (8)	10 kHz (4)	10 kHz (2)	10 kHz (1)
F5	FREQUENCY- 1 kHz (BCD)		0-9	1 kHz (8)	1 kHz (4)	1 kHz (2)	1 kHz (1)
F6	FREQUENCY- 100 Hz (BCD)		0-9	100 Hz (8)	100 Hz (4)	100 Hz (2)	100 Hz (1)
F7	FREQUENCY- 10 Hz (BCD)		0-9	10 Hz (8)	10 Hz (4)	10 Hz (2)	10 Hz (1)
F8	FREQUENCY 1 Hz (BCD)		0-9	1 Hz (8)	1 Hz (4)	1 Hz (2)	1 Hz (1)
S	END DELIMITER		S	NA	NA	NA	NA
- - A1 A2 SD M1 M2 M3 M4 M5 M6 M7 M8 S			WORD 2 CHARACTER SEQUENCE				
-	HYPHEN		-	NA	NA	NA	NA
-	HYPHEN		-	NA	NA	NA	NA
A1	ADDRESS, M.S.D. (BCD)		0-3	0	0	A1(2)	A1(1)
A2	ADDRESS, L.S.D. (BCD)		0-9	A2(8)	A2(4)	A2(2)	A2(1)
SD	SEQUENCE DESIGNATOR		5	NA	NA	NA	NA
M1	RESERVED		0	0	0	0	0
M2	RESERVED		0	0	0	0	0
M3	RESERVED		0	0	0	0	0
M4	RESERVED		0	0	0	0	0
M5	RESERVED		0	0	0	0	0
M6	PEAK CLIPPER ENABLE		0	0	0	0	PEAK CLIPPER ENABLE
M7	MODE		0-9, A-F	0	AM ENABLE	CW ENABLE	ISB ENABLE
M8	ISB CHANNEL ENABLES		0-9, A-F	B2 ENABLE	B1 ENABLE	A1 ENABLE	A2 ENABLE
S	END DELIMITER		S	NA	NA	NA	NA
- - A1 A2 SD V1 V2 V3 V4 V5 V6 V7 V8 S			WORD 3 CHARACTER SEQUENCE				
-	HYPHEN		-	NA	NA	NA	NA
-	HYPHEN		-	NA	NA	NA	NA
A1	ADDRESS, M.S.D. (BCD)		0-3	0	0	A1(2)	A1(1)
A2	ADDRESS, L.S.D. (BCD)		0-9	A2(8)	A2(4)	A2(2)	A2(1)
SD	SEQUENCE DESIGNATOR		9	0	0	0	0
V1	RESERVED		0	0	0	0	0
V2	RESERVED		0	0	0	0	0
V3	RESERVED		0	0	0	0	0
V4	RESERVED		0	0	0	0	0
V5	AUXILIARY		0-9, A-F	-	-	-	-
V6	AUXILIARY		0-9, A-F	-	-	-	-
V7	RESERVED		0	0	0	0	0
V8	PILOT CARRIER/PA CONTROL		0-9, A-F	PILOT CARRIER ENABLE	PA LOW PWR ENABLE	PA HIGH VOLT ENABLE	PA LOW VOLT ENABLE
S	END DELIMITER		S	NA	NA	NA	NA
- - A1 A2 SD S1 S2 S3 S4 S5 S6 S7 S8 S			WORD 4 CHARACTER SEQUENCE				
-	HYPHEN		-	NA	NA	NA	NA
-	HYPHEN		-	NA	NA	NA	NA
A1	ADDRESS, M.S.D. (BCD)		0-3	0	0	A1(2)	A1(1)
A2	ADDRESS, L.S.D. (BCD)		0-9	A2(8)	A2(4)	A2(2)	A2(1)
SD	SEQUENCE DESIGNATOR		D	NA	NA	NA	NA
S1	EXCITER FAULT /KEY MONITOR		0-3	0	0	EXCITER FAULT	SYSTEM KEY MONITOR
S2	AF MONITORS		0-9, A-F	B2 AF MONITOR	B1 AF MONITOR	A1 AF MONITOR	A2 AF MONITOR
S3	SYNTH FAULTS		0-9, A-F	0	10 Hz LOCK FAULT	100 Hz LOCK FAULT	1 kHz LOCK FAULT
S4	SYNTH FAULTS		0-9, A-F	10 kHz LOCK FAULT	100 kHz LOCK FAULT	SYNTH OUT LOCK FAULT	FREQ REF FAULT
S5	SUBCARRIER FAULT/RF MON/PWR SPLY FAULT		0-7	0	SUBCARR LOCK FAULT	EXCITER RF MONITOR	EXCTR PWR SPLY FAULT
S6	EXTERNAL STD/IF MONITOR		0-9, A-F	0	EXTERNAL STANDARD	A1 IF MONITOR	0
S7	PA/COUPLER STATUS		0-9, A-F	PA READY	PA FAULT	PA RF MONITOR	COUPLER FAULT
S8	PRESEL FAULT/DATA ERROR/LOCAL/MONITOR		0-9, A-F	PRESEL FAULT	DATA ERROR	LOCAL CONTROL	MONITOR
S	END DELIMITER		S	NA	NA	NA	NA

TPA-3015-014

ASCII Character Monitor Word Format  
Figure 5

Table 3. Address Number, Binary Data Pattern, and Address Recognition Strapping.

ADDRESS THUMB-WHEEL NUMBER	TRANSMITTED BINARY ADDRESS DATA				EXCITER STRAPPING REQUIRED FOR ADDRESS RECOGNITION			
	A4	A3	A2	A1	A4 (ADB4)	A3 (ADB3)	A2 (ADB2)	A1 (ADB1)
0	1	1	1	1	-	-	-	-
1	1	1	1	0	-	-	-	X
2	1	1	0	1	-	-	X	-
3	1	1	0	0	-	-	X	X
4	1	0	1	1	-	X	-	-
5	1	0	1	0	-	X	-	X
6	1	0	0	1	-	X	X	-
7	1	0	0	0	-	X	X	X
8	0	1	1	1	X	-	-	-
9	0	1	1	0	X	-	-	X
10	0	1	0	1	X	-	X	-
11	0	1	0	0	X	-	X	X
12	0	0	1	1	X	X	-	-
13	0	0	1	0	X	X	-	X
14	0	0	0	1	X	X	X	-
15	0	0	0	0	X	X	X	X

**Note**

- indicates no strapping, X indicates strapping to ground.

Table 4. Control and Monitor Word Sequence Designators.

SEQUENCE DESIGNATORS				SIGNIFICANCE
WORD 1	WORD 2	WORD 3	WORD 4	
0	4	8	C	Control word with request for status followup.
*1	5	9	D	Control word only -- no status followup desired.
**2	6	A	E	No command -- status followup only desired.

\*Monitor words 1, 2, 3, and 4 contain sequence designators 1, 5, 9, or D respectively.  
 \*\*These sequence designators are used to request monitor words 1, 2, 3, or 4 and must be followed immediately by the X (control word terminator), thereby bypassing the data characters in the control word structure.

Table 5. ASCII Character Codes.

4-BIT FUNCTION CODE				ASCII CHARACTER	ASCII CHARACTER 7-BIT CODE						
2 <sup>3</sup>	2 <sup>2</sup>	2 <sup>1</sup>	2 <sup>0</sup>		b <sub>7</sub>	b <sub>6</sub>	b <sub>5</sub>	b <sub>4</sub>	b <sub>3</sub>	b <sub>2</sub>	b <sub>1</sub>
0	0	0	0	0	0	1	1	0	0	0	0
0	0	0	1	1	0	1	1	0	0	0	1
0	0	1	0	2	0	1	1	0	0	1	0
0	0	1	1	3	0	1	1	0	0	1	1
0	1	0	0	4	0	1	1	0	1	0	0
0	1	0	1	5	0	1	1	0	1	0	1
0	1	1	0	6	0	1	1	0	1	1	0
0	1	1	1	7	0	1	1	0	1	1	1
1	0	0	0	8	0	1	1	1	0	0	0
1	0	0	1	9	0	1	1	1	0	0	1
1	0	1	0	A	1	0	0	0	0	0	1
1	0	1	1	B	1	0	0	0	0	1	0
1	1	0	0	C	1	0	0	0	0	1	1
1	1	0	1	D	1	0	0	0	1	0	0
1	1	1	0	E	1	0	0	0	1	0	1
1	1	1	1	F	1	0	0	0	1	1	0
				*CR	0	0	0	1	1	0	1
				*LF	0	0	0	1	0	1	0
				*X	1	0	1	1	0	0	0
				*-	0	1	0	1	1	0	1
				*\$	0	1	0	0	1	0	0
*Denotes special nonfunctional character											

4.3.7.2.1 Control Word

In the following paragraphs, the bit structure is shown for a typical control word. The control word is being sent to an exciter with an address of 15, and the sequence designator tells the exciter that this is a control word with a request for a status followup. The frequency to which the exciter will tune is 27.548 300 MHz.



a. Word 1 (Frequency Control Word)

**Note**

The following characters are the same for all four control words so the format for these characters will only be shown for word 1.

Nonfunctional: #1 (CR), #2 (LF), #3 (X)

Functional: #1 (A1), #2 (A2) -

Nonfunctional character #1 — Set bits for carriage return (CR).

NONFUNCTIONAL CHARACTER #1						
b <sup>7</sup>	b <sup>6</sup>	b <sup>5</sup>	b <sup>4</sup>	b <sup>3</sup>	b <sup>2</sup>	b <sup>1</sup>
0	0	0	1	1	0	1

Nonfunctional character #2 — Set bits for line feed (LF).

NONFUNCTIONAL CHARACTER #2						
b <sup>7</sup>	b <sup>6</sup>	b <sup>5</sup>	b <sup>4</sup>	b <sup>3</sup>	b <sup>2</sup>	b <sup>1</sup>
0	0	0	1	0	1	0

Functional character #1 — Set bits to select MSD of address.

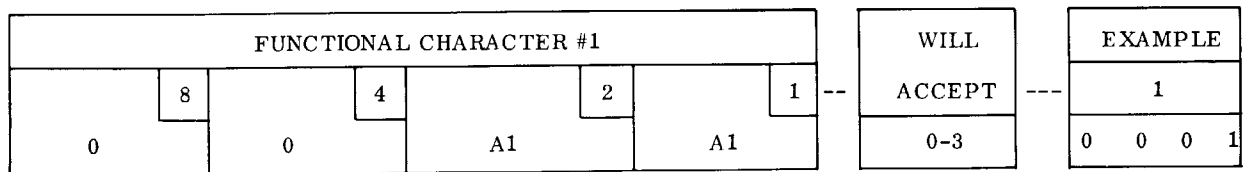

Functional character #2 — Set bits to select LSD of address.

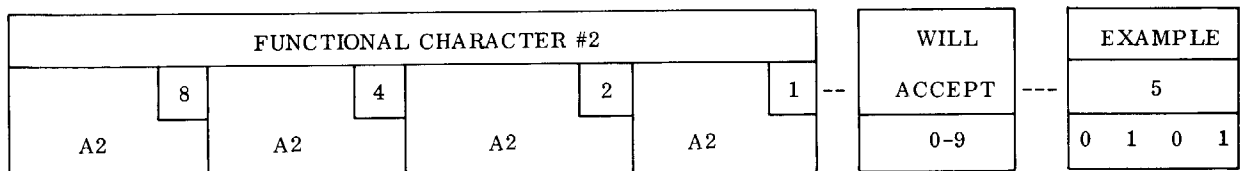

Functional character #3 — Set bits for 0 to select sequence designator.

FUNCTIONAL CHARACTER #3				WILL	EXAMPLE
8	4	2	1	ACCEPT	0
NA	NA	NA	NA	0, 1, 2	0 0 0 0

Functional character #4 — Set bits to select 10-MHz frequency.

FUNCTIONAL CHARACTER #4				WILL	EXAMPLE
8	4	2	1	ACCEPT	2
0	0	10 MHz	10 MHz	0, 1, 2	0 0 1 0

Functional character #5 — Set bits to select 1-MHz frequency.

FUNCTIONAL CHARACTER #5				WILL	EXAMPLE
8	4	2	1	ACCEPT	7
1 MHz	1 MHz	1 MHz	1 MHz	0-9	0 1 1 1

Functional character #6 — Set bits to select 100-kHz frequency.

FUNCTIONAL CHARACTER #6				WILL	EXAMPLE
8	4	2	1	ACCEPT	5
100 kHz	100 kHz	100 kHz	100 kHz	0-9	0 1 0 1

Functional character #7 — Set bits to select 10-kHz frequency.

FUNCTIONAL CHARACTER #7				WILL	EXAMPLE
8	4	2	1	ACCEPT	4
10 kHz	10 kHz	10 kHz	10 kHz	0-9	0 1 0 0

Functional character #8 — Set bits to select 1-kHz frequency.

FUNCTIONAL CHARACTER #8				WILL	EXAMPLE
8	4	2	1	ACCEPT	8
1 kHz	1 kHz	1 kHz	1 kHz	0-9	1 0 0 0

Functional character #9 — Set bits to select 100-Hz frequency.

FUNCTIONAL CHARACTER #9				WILL	EXAMPLE
8	4	2	1	ACCEPT	3
100 Hz	100 Hz	100 Hz	100 Hz	0-9	0 0 1 1

Functional character #10 — Set bits to select 10-Hz frequency. (Only used with exciter that can be tuned to 10 Hz or 1 Hz. Set to zero's for 100-Hz tuning.)

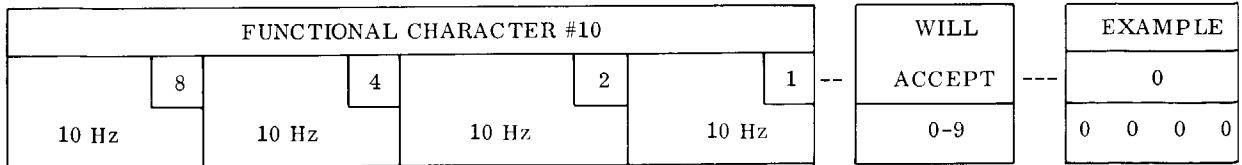

Functional character #11 — Set bits to select 1-Hz frequency. (Only used with exciter that can be tuned to 1 Hz. Set to zero's for 10-Hz and 100-Hz tuning.)

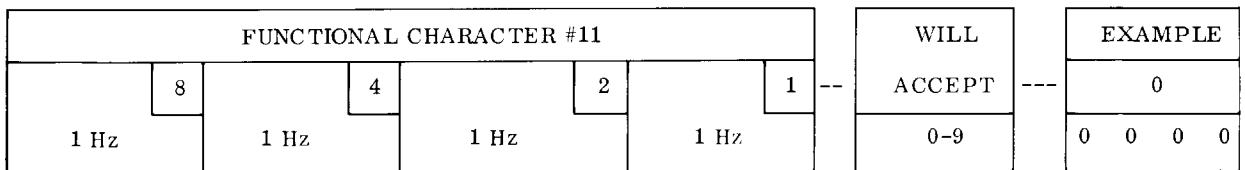

Nonfunctional character #3 — Set bits for execute (X).

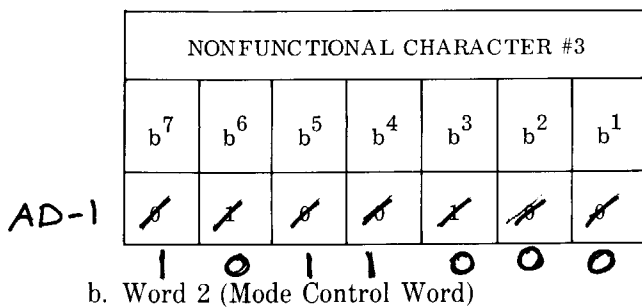

Functional character #3 — Set bits to 4 to select sequence designator.

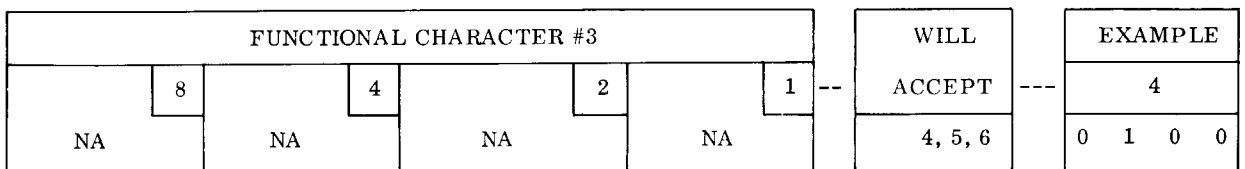

Functional characters #4 through #8 are not used, and the bits are set to zero.

Functional character #9 — Set bit to enable peak clipper (example: peak clipper enabled).

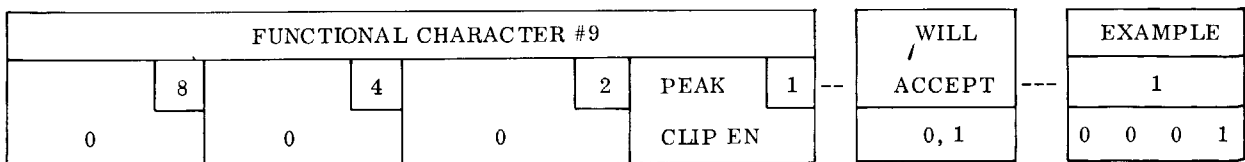

Functional character #10 — Set bits to select MODE (example: ISB mode enabled).

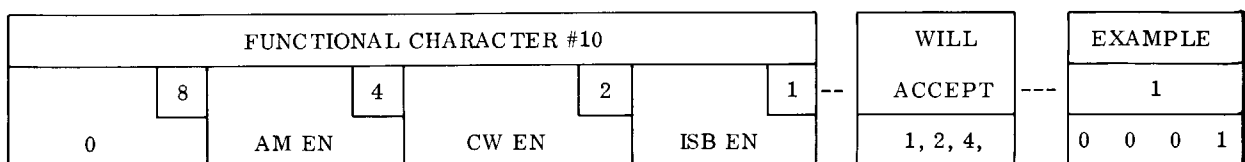

Functional character #11 — Set bits to select ISB channel. Mode must be ISB (example: channels B2, A1 enabled).

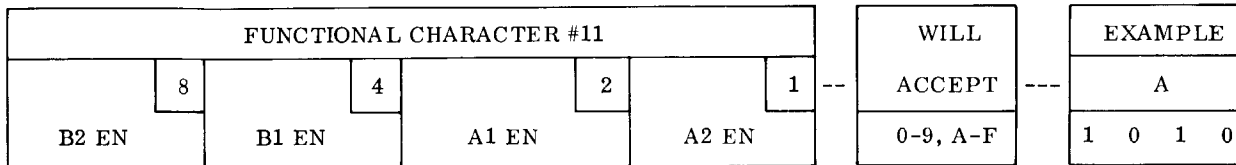

c. Word 3 (PA Control Word)

Functional character #3 — Set bits to 8 to select sequence designator.

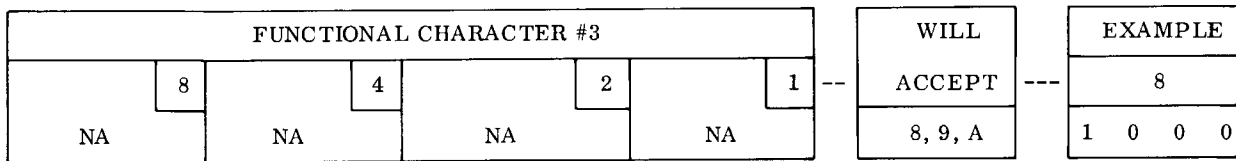

Functional characters #4 through #7 are not used and the bits are set to zero.

Functional characters #8 and #9 are auxiliary characters and are available to control and monitor external user functions. Input/output interface levels are 5-volt CMOS logic compatible.

Functional character #10 is not used, and the bits are set to zero.

Functional character #11 — Set bits to enable pilot carrier and control pa (example: pilot carrier disabled, pa low voltage enabled).

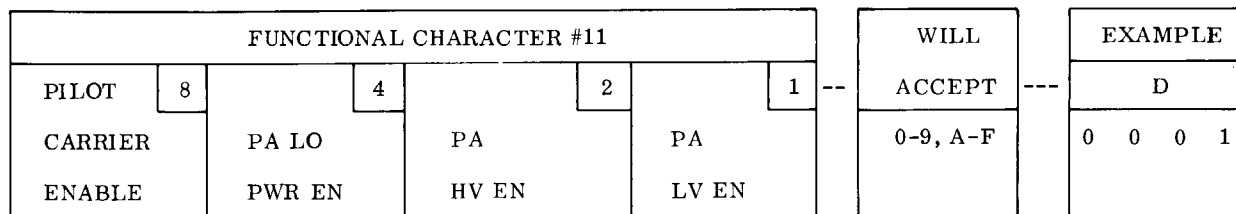

d. Word 4 (Key Control Word)

Contains only four functional characters. Functional characters #1 and #2 are identical to words 1, 2, and 3 as explained above.

Functional character #3 — Set bits to C to select sequence designator.

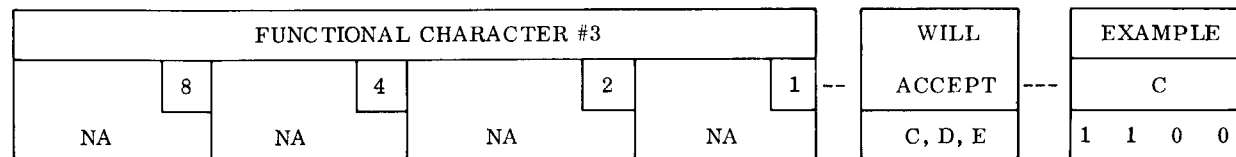

Functional character #4 — Set bits to key exciter (example: exciter keyed).

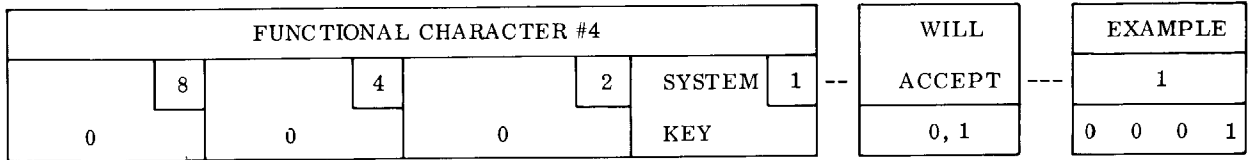

After functional character #4, X is transmitted to terminate word 4 at the end of functional character #4.

**4.3.7.2.2 Monitor Word**

In the following paragraphs, the bit structure that differs from that of the control word is shown. The bit structure that is the same for the control and monitor words is noted. The address characters (functional characters #1 and #2) are the same as for the control word and will not be repeated here.

a. Word 1 (Frequency Monitor Word)

**Note**

The following characters are the same for all four monitor words, so the format for these characters will be shown only for word 1:

Nonfunctional: #1 (-), #2 (-), #3 (\$)

Nonfunctional character #1 — Set bits for hyphen (-).

NONFUNCTIONAL CHARACTER #1						
b <sup>7</sup>	b <sup>6</sup>	b <sup>5</sup>	b <sup>4</sup>	b <sup>3</sup>	b <sup>2</sup>	b <sup>1</sup>
0	1	0	1	1	0	1

Nonfunctional character #2 — Set bits for hyphen (-).

NONFUNCTIONAL CHARACTER #2						
b <sup>7</sup>	b <sup>6</sup>	b <sup>5</sup>	b <sup>4</sup>	b <sup>3</sup>	b <sup>2</sup>	b <sup>1</sup>
0	1	0	1	1	0	1

Functional character #3 — Set bits for 1 to select sequence designator.

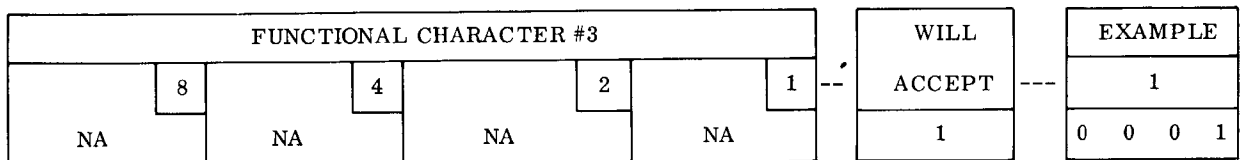

Functional characters #4 through #11 same as for control word 1 (paragraph 4.3.7.2.1.a).

Nonfunctional character #3 — Set bits for dollar sign (\$).

NONFUNCTIONAL CHARACTER #3						
b <sup>7</sup>	b <sup>6</sup>	b <sup>5</sup>	b <sup>4</sup>	b <sup>3</sup>	b <sup>2</sup>	b <sup>1</sup>
0	1	0	0	1	0	0

b. Word 2 (Mode Monitor Word)

Functional character #3 — Set bits for 5 to select sequence designator.

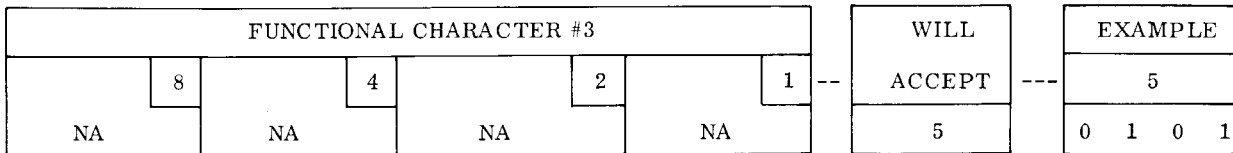

Functional characters #4 through #11 same as for control word 2 (paragraph 4.3.7.2.1.b).

c. Word 3 (PA Monitor Word)

Functional character #3 — Set bits for 9 to select sequence designator.

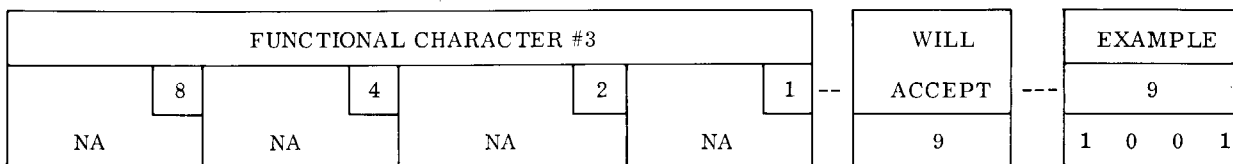

Functional characters #4 through #11 same as for control word 3 (paragraph 4.3.7.2.1.c).

d. Word 4 (Performance and Fault Monitor Word)

Word 4 contains performance monitor and fault information that can be used in a processor-controlled system to detect faults in the exciter or units controlled by the exciter or to detect unsatisfactory performance in the transmit signal path.

Functional character #3 — Set bits for D to select sequence designator.

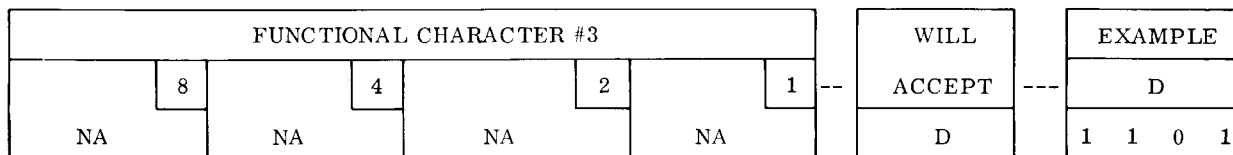

Functional character #4 — Exciter fault and system key monitor, logic 1 indicates fault/system key (example: exciter fault, no system key).

FUNCTIONAL CHARACTER #4				WILL	EXAMPLE
0	8	0	4	EXCITER FAULT	2
				SYSTEM KEY	0 0 1 0
				ACCEPT	
				0-3	

Functional character #5 — Af monitors, logic 0 indicates line audio input exceeds -10 dB of level required to produce full power output (example: all channels have audio input within monitor range).

FUNCTIONAL CHARACTER #5				WILL	EXAMPLE				
B2	8	B1	4	A1	2	A2	1	ACCEPT	0
AF MON		AF MON		AF MON		AF MON		0-9, A-F	0 0 0 0

Functional character #6 — Synthesizer 10-Hz, 100-Hz, and 1-kHz loss-of-lock faults, logic 1 indicates out-of-lock (example: all signals locked).

FUNCTIONAL CHARACTER #6				WILL	EXAMPLE				
0	8	10-Hz	4	100-Hz	2	1-kHz	1	ACCEPT	0
		LOCK FAULT		LOCK FAULT		LOCK FAULT		0-7	0 0 0 0

Functional character #7 — Synthesizer 10-kHz, 100-kHz, and output (1-MHz and 10-MHz) loss-of-lock faults and synthesizer reference faults (9.9-MHz, 118-MHz, or 450-kHz injection levels insufficient), logic 1 indicates out-of-lock/fault (example: 10-kHz and 100-kHz unlocked, output locked and injection levels sufficient).

FUNCTIONAL CHARACTER #7				WILL	EXAMPLE				
10-kHz	8	100-kHz	4	SYNTH	2	SYNTH	1	ACCEPT	C
LOCK FAULT		LOCK FAULT		OUTPUT LOCK FAULT		REF LOCK FAULT		0-9, A-F	1 1 0 0

Functional character #8 — Synthesizer subcarrier loss-of-lock fault, logic 1 indicates out of lock for either subcarrier injection phase-lock loop. Exciter rf monitor, logic 0 indicates exciter rf output level exceeds -7 dB mW. Exciter power supply fault, logic 1 indicates loss of any of the power supply voltages except +5 V dc. Loss of +5-V dc power voltage will cause a logic 0 to be presented regardless of the state of the other power supply voltages (example: synthesizer subcarrier unlocked, rf output level insufficient, exciter power supply fault).

FUNCTIONAL CHARACTER #8				WILL	EXAMPLE				
0	8	SYNTH	4	EXCITER	2		1	ACCEPT	7
		SUBCAR LOCK FAULT		RF MONITOR		EXCITER PWR SPL FAULT		0-7	0 1 1 1





WORD	CHAR-ACTER	STOP BIT	PARITY BIT	CHARACTER BIT POSITION								START BIT	REF NOTES
				B8	B7	B6	B5	B4	B3	B2	B1		
1	1	1	X	WORD SYNC		SUBADDRESS		ADDRESS				0	②
				1	1	0	0	A4	A3	A2	A1	0	
	2	1	X	CMD/STATUS REQ		FREQ (10 MHz)		FREQ (1 MHz)				0	
				$\bar{C}=0$	$\bar{S}=1$	(2)	(1)	(8)	(4)	(2)	(1)	0	
	3	1	X	FREQ (100 kHz)				FREQ (10 kHz)				0	
			(8)	(4)	(2)	(1)	(8)	(4)	(2)	(1)	0		
4	1	X	FREQ (1 kHz)				FREQ (100 Hz)				0		
			(8)	(4)	(2)	(1)	(8)	(4)	(2)	(1)	0		
5	1	X	FREQ (10 Hz)				FREQ (1 Hz)				0		
			(8)	(4)	(2)	(1)	(8)	(4)	(2)	(1)	0		
2	1	1	X	WORD SYNC		SUBADDRESS		ADDRESS				0	②
				1	1	0	1	A4	A3	A2	A1	0	
	2	1	X	CMD/STATUS REQ		RESERVED						0	
				$\bar{C}=0$	$\bar{S}=1$	0						0	
	3	1	X	RESERVED								0	
4	1	X	RESERVED								PEAK CLIPPER ENABLE	0	
5	1	X	MODE SELECT				CHAN B2 ENABLE	CHAN B1 ENABLE	CHAN A1 ENABLE	CHAN A2 ENABLE	0		
			0	AM	FM	ISB					0		
3	1	1	X	WORD SYNC		SUBADDRESS		ADDRESS				0	②
				1	1	1	0	A4	A3	A2	A1	0	
	2	1	X	CMD/STATUS REQ		RESERVED						0	
				$\bar{C}=0$	$\bar{S}=1$	0						0	
	3	1	X	RESERVED								0	
4	1	X	AUXILIARY								0		
5	1	X	RESERVED				PILOT CARRIER ENABLE	PA LOW POWER ENABLE	PA HIGH VOLTAGE ENABLE	PA LOW VOLTAGE ENABLE	0		
4	1	1	X	WORD SYNC		SUBADDRESS		ADDRESS				0	②
				1	1	1	1	A4	A3	A2	A1	0	
	2	1	X	CMD/STATUS REQ		EXCITER FAULT	SYSTEM KEY	B2 AF MON	B1 AF MON	A1 AF MON	A2 AF MON	0	
				$\bar{C}=0$	$\bar{S}=1$							0	
	3	1	X	0	10 Hz LOCK FAULT	100 Hz LOCK FAULT	1 kHz LOCK FAULT	10 kHz LOCK FAULT	100 kHz LOCK FAULT	SYN OUT LOCK FAULT	FREQ REF FAULT	0	
4	1	X	0	SUBCARR LOCK FAULT	EXCITER RF MON	EXCITER PWR SPLY FAULT	0	EXTERNAL STANDARD	A1 IF MON	0	0		
5	1	X	PA READY	PA FAULT	PA RF MON	COUPLER FAULT	PRE-SELECTOR FAULT	DATA ERROR	LOCAL CONTROL	MONITOR	0		

NOTES:

- ① 1=LOGIC 1; 0=LOGIC 0; X=FUNCTION OF STRAPPING; (1),(2),(4) (8)=BINARY WEIGHT OF BIT POSITION.
- ② FROM A CONTROL UNIT, ONLY CHARACTERS 1 AND 2 ARE TRANSMITTED IN WORD 4; ONLY STATUS REQUEST ( $\bar{C}=1, \bar{S}=0$ ) IS TRANSMITTED IN WORDS 1, 2, AND 3. ALL MONITOR WORDS ARE 5 CHARACTERS LONG.
- ③ MONITOR WORD 4 CHARACTERS 3, 4, AND 5 CONTAIN FAULT AND PERFORMANCE MONITOR BITS FOR WHICH NO CORRESPONDING CONTROL BITS EXIST. DATA ERROR BIT IS THE LOGICAL SUM OF THE FOLLOWING CONDITIONS:
  - A. RECEIVED CHARACTER PARITY ERROR.
  - B. FRAMING ERROR (NO VALID STOP RECEIVED WITH THE CHARACTER)
  - C. OVERRUN ERROR (PREVIOUS CHARACTER NOT PROCESSED BEFORE THE CURRENT CHARACTER WAS RECEIVED).
  - D. INVALID CHARACTER SEQUENCE.

TPA-2862-014

8-Bit Character Control and Monitor Word Format  
Figure 6

Remainder of word 1 — Set pattern to correspond to bcd frequency information to be transmitted to the controlled exciter (logic 1 enable, logic 0 disable).

b. Word 2 (Mode Control Word)

Character 1 — Set bits as indicated in figure 6.

Character 2 — Set b8 and b7 as indicated in note 1 of figure 6.

Remainder of character 2 — Not used in exciter.

Character 3 — Not used in exciter.

Character 4 — b8 through b2 not used in exciter. Set b1 to logic 1 to enable peak clipper.

Character 5 — Set appropriate bit to logic 1 to enable desired function, logic 0 to disable function.

**Note**

For ISB mode, one or more channels (B2, B1, A1, A2) must be enabled.

c. Word 3 (PA Control Word)

Character 1 — Set bits as indicated in figure 6.

Character 2 — Set b8 and b7 as indicated in note 1 of figure 6.

Remainder of character 2 — Not used in exciter.

Character 3 — Not used in exciter.

Character 4 — Not used in exciter.

Character 5 — Pilot carrier, set b4 to logic 1 to enable. Pilot carrier, logic 0 to disable pilot carrier.

Low-power enable, set b3 to logic 1 to enable pa low-power circuits.

High-voltage enable, set b2 to logic 1 to enable pa high-voltage circuits.

Low-voltage enable, set b1 to logic 1 to enable filament and other low-voltage circuits of pa.

d. Word 4 (Key Control Word)

Character 1 — Set bits as indicated in figure 6.

Character 2 — Set b8 and b7 as indicated in note 1 of figure 6. Set b5 to logic 1 to key exciter/pa.

Remainder of word 4 — Status information only as follows. (Information sent to control station from exciter for monitoring purposes.)

**4.3.7.5 Performance Monitor and Fault Information**

Word 4 contains performance monitor and fault information that can be used in a processor-controlled system to detect faults in the exciter or units controlled by the exciter or detect unsatisfactory performance in the transmit signal path.

a. Fault Monitors

Exciter fault (character 2, b6) — Logic 1 fault summary of synthesizer lock fault and power supply fault. Latches on power supply fault to indicate short-term power failures. Requires control sending frequency command (word 1) to reset to logic 0.

10-Hz lock fault (character 3, b7) — Logic 1 when 10-Hz decade phase-lock loop is unlocked, logic 0 if locked.

100-Hz lock fault (character 3, b6) — Logic 1 when 100-Hz decade phase-lock loop is unlocked, logic 0 if locked.

1-kHz lock fault (character 3, b5) — Logic 1 when 1-kHz decade phase-lock loop is unlocked, logic 0 if locked.

10-kHz lock fault (character 3, b4) — Logic 1 when 10-kHz decade phase-lock loop is unlocked, logic 0 if locked.

100-kHz lock fault (character 3, b3) — Logic 1 when 100-kHz decade phase-lock loop is unlocked, logic 0 if locked.

Synthesizer output lock fault (character 3, b2) — Logic 1 when 10/1-MHz phase-lock loop is unlocked, logic 0 if locked.

Frequency reference fault (character 3, b1) — Logic 1 when any synthesizer reference injection output (9.9 MHz, 118 MHz, or 450 kHz) is insufficient, logic 0 if all are satisfactory.

Subcarrier lock fault (character 4, b7) — Logic 1 when either subcarrier phase-lock loop is unlocked, logic 0 if both are locked.

Exciter power supply fault (character 4, b5) — Logic 1 if any power supply voltage (except +5 V dc) fails, logic 0 if all power supply voltages are okay or +5-V dc supply fails.

Pa fault (character 5, b7) — Logic 1 if exciter receives pa fault indication from associated power amplifier, logic 0 if no fault.

Coupler fault (character 5, b5) — Logic 1 if exciter receives coupler fault indication from associated antenna coupler, logic 0 if no fault.

Preselector fault (character 5, b4) — Logic 1 if exciter receives preselector fault indication from associated preselector, logic 0 if no fault.

Data error (character 5, b3) — Logic 1 when data error occurs in receiving control information since last monitor data response, logic 0 if no data error. Reset when any monitor word is transmitted from exciter.

b. Performance Monitors

Logic 0 signal from the rf performance monitor indicates presence of signal.

System key monitor (character 2, b5) — Logic 0 when system is keyed.

Channel B2 af monitor (character 2, b4), channel B1 af monitor (character 2, b3), channel A1 af monitor (character 2, b2), channel A2 af monitor (character 2, b1) — Logic 0 when line audio input

exceeds -10 dB of level required to produce full power output.

Exciter rf monitor (character 4, b6) — Logic 0 when the exciter rf output level exceeds -7 dB mW, logic 1 is less than -7 dB mW.

A1 if monitor (character 4, b2) — Logic 0 when channel A1 if output level (9.45-MHz if) exceeds -10 dB of level required to produce full power output, logic 1 if less than -10 dB of level required to produce full power output.

External standard (character 4, b3) — Logic 1 when external standard is being used, logic 0 when internal standard is being used.

Pa ready (character 5, b8) — Logic 1 when the associated power amplifier is tuned and ready to transmit.

Pa rf monitor (character 5, b6) — Logic 1 when associated power amplifier is transmitting rf power to load.

Local control (character 5, b2) — Logic 1 when exciter is in local control mode, logic 0 when in remote.

Monitor (character 5, b1) — Logic 1 when exciter front-panel control switch is pressed to MON position. Can be used, for example, for operator to store front-panel settings in preset table in the processor.



Rockwell  
International

# HF-8014( ) Exciter

theory

Collins Telecommunications Products Division

523-0770724-001218

1 January 1981

Printed in USA

## table of contents

<i>Paragraph</i>	<i>Page</i>
1. <i>General</i> .....	1
2. <i>Functional Theory</i> .....	1
2.1 Transmit Function .....	1
2.2 Mode and Operating Controls .....	2
2.2.1 Mode Selection .....	2
2.2.2 Key and Carrier Control Circuits .....	11
2.2.3 Audio .....	11
2.2.4 ALC/TGC and Tune Start .....	21
2.2.5 Frequency Control .....	22
2.3 Remote Control Operation .....	22
2.3.1 General .....	22
2.3.2 Exciter Serial Control Operation .....	29
2.4 Frequency Synthesizer .....	30
2.4.1 General .....	30
2.4.2 Synthesizer Reference .....	30
2.4.3 Synthesizer Subcarrier Generator .....	30
2.4.4 Synthesizer End Decade .....	41
2.4.5 Synthesizer Decades .....	41
2.4.6 Synthesizer Output .....	42
2.5 Monitor Functions .....	51
2.5.1 Fault and Status Indicators .....	51
2.5.2 Metering .....	52
2.6 Power Distribution .....	53



## 1. GENERAL

This section provides functional theory of the HF-8014( ) Exciter to the circuit card/module level. Theory for individual circuit cards/modules is presented in the circuit card/module section (part 2) of this instruction book.

The HF-8014( ) Exciter controls and monitors are located on the front panel (refer to figure 1). The HF-8014( ) Exciter is locally controlled only, and does not contain parallel input A11, parallel output A12, or serial interface A13. Note also that in the HF-8014( ) Exciter, the CONT switch must be kept in the LCL position. The HF-8014A Exciter is locally or remotely controlled, depending on the setting of the CONT switch. When the CONT switch is in the REM position, the HF-8014A Exciter is controlled by the HF-8093 Exciter Control, a processor, or other compatible control through the REMOTE CONTROL connector (J14) on the rear panel of the exciter.

## 2. FUNCTIONAL THEORY (Refer to figure 1.)

The HF-8014( ) Exciter is frequency-controlled directly from the front panel. Bcd frequency signals from the front panel are applied directly to the synthesizer (A17 through A23) and to control A10. The bcd frequency signals are used to establish the frequency of the vfo output (109.35 to 79.35001 MHz) from the synthesizer and control the preselector and pa outputs from control A10.

The HF-8014( ) Exciter operating mode is controlled directly from the front panel. Mode signals from the front panel are applied directly to control A10 and to selected audio and if cards. This controls all mode switching in the exciter and provides necessary mode signals for the associated power amplifier.

The HF-8014( ) Exciter transmit audio signals are applied at either the MIC jack on the front panel or the channel A1, channel A2, channel B1, and Channel B2 line inputs on the rear panel. These signals are applied to transmit audio A4 (A1-B1) and transmit audio A3 (A2-B2) where the audio channel is determined by the setting of the front-panel CHANNEL

ENABLE switches in conjunction with the MODE switch. The audio output from the transmit audios A3 and A4 is applied to if amplifiers A5 through A8. The if channels A1, A2, B1, and B2 are enabled in accordance with the MODE switch setting and the CHANNEL ENABLE switches. In the if cards the audio signal is converted to the first if signal and then mixed with 9.9 MHz to produce the 9.45-MHz second if that is supplied to rf translator A9. The first if signal is obtained by mixing the audio signal with 450 kHz on the channel A1 if and the channel B1 if, with 456.29 kHz on the channel A2 if, and with 443.71 kHz on the channel B2 if. The 9.9-MHz mixing is accomplished only on channel A1 if A8. The 9.45-MHz signal applied to rf translator A9 is mixed with the fixed 118.8-MHz injection signal and the vfo injection signal to provide an rf output signal to drive the power amplifier. The level of the output signal is controlled by the TGC signal during the system tuning operation and by the ALC signal during normal transmission.

### 2.1 Transmit Function (Refer to figure 2.)

Channel B1, channel B2, and channel A2 are only enabled in the ISB (independent sideband) mode. In ISB operation, channel A1 input signals are upper sideband signals and channel A2 input signals are upper-upper sideband signals. Likewise, channel B1 input signals are lower sideband signals and channel B2 input signals are lower-lower sideband signals. In the AM and CW modes, only the channel A1 circuits are active and provide outputs.

With a key applied, the enabled sideband is transmitted when an audio signal is applied. Transmit audio signals are applied to transmit audio A4 (A1-B1) and transmit audio A3 (A2-B2). The outputs of transmit audio A4 (A1-B1) are applied to channel A1 if A8 and channel B1 if A7. In a like manner the outputs of transmit audio A3 (A2-B2) are applied to channel A2 if A6 and channel B2 if A5. In channel B2 if A5, the audio is mixed with a 443.71-kHz injection signal and the output applied to channel A1 if A8. In channel A2 if A6, the audio is mixed with a 456.29-kHz injection signal and the output applied to channel A1 if A8. In channel B1 if A7, the audio is mixed with a 450-kHz

injection signal and applied to channel A1 if A8. The channel A1 audio is mixed with a 450-kHz injection signal on channel A1 if A8 and is then applied thru a bandpass filter with the outputs from the other if circuit cards to a 9.9-MHz mixer-amplifier on channel A1 if A8. The 9.9-MHz fixed injection signal mixes with the if signals to provide a 9.45-MHz if signal to be supplied to rf translator A9. The 9.45-MHz if signal is mixed with the 118.8-MHz fixed injection signal and the vfo injection signal to provide a 1.6000- to 29.9999-MHz rf output signal.

The transmit audio signals are supplied at the MIC jack on the front panel or the XMT AF terminals on the rear panel. In the CW mode, a tone generator on transmit audio A4 supplies an audio tone to the PHONES jack on the front panel when the CW KEY is closed.

The transmit key signals are supplied at the MIC jack on the front panel, the EXT KEY terminals on the rear panel, the KEY switch on the front panel (in the lock position), or the CW KEY jack on the front panel.

When transmitting in the ISB mode using a microphone connected to the MIC jack, transmit audio signals are applied to the microphone audio amplifier on transmit audio A4. The output of the microphone amplifier is compressed to prevent overdriving and applied to the microphone af input circuits on transmit audio A3 and A4. The audio signal is then applied to channel A1, channel A2, channel B1, or channel B2 (as selected by front-panel CHANNEL ENABLE switches) audio circuits. The microphone select signal disables the audio line input to the selected channel and enables the microphone input. At the same time, the compression amplifier circuits for that channel are disabled.

When the CHANNEL ENABLE switches are placed in the LINE position, the audio signal is applied to each individual channel from the line inputs on the rear panel of the exciter. The audio signal is applied to the individual line amplifier, through the line audio switch to the audio circuits. The compression amplifier circuits are enabled to prevent overdriving the exciter. The transmit audio is then applied to the corresponding if amplifier circuit card.

On the if amplifier cards, the transmit audio is applied to a balanced modulator and then to the 9.9-MHz mixer-amplifier on channel A1 if A8. The resultant difference frequency (9.45-MHz) is coupled to rf translator A9 and mixed in a difference mixer with a 118.8-MHz fixed injection signal in the first mixer.

The resultant 109.35-MHz output is applied through a crystal filter to the second difference mixer where it is mixed with a 109.35- to 79.35-MHz vfo frequency. The output signal from the second mixer is amplified and supplied at the XMT OUT jack for use by an associated power amplifier.

## **2.2 Mode and Operating Controls**

The mode and operating controls consist of front-panel switches and an external remote device, if used. The exciter has a frequency control, a pa power control, a key control, a pilot carrier control, a peak clip control, channel enable controls, a local/remote control, phones select with level control, meter control, a mode control, and a power switch. The HF-8014A Exciter can be used with an external remote control device such as the HF-8093 Exciter Control.

### **2.2.1 Mode Selection (Refer to figure 3.)**

The MODE switch is enabled by +5 V dc from the control (CONT) switch. The +5-V dc voltage is routed to the MODE switch when the CONT switch is placed in the LCL position. When the CONT switch is in the REM position, the +5-V dc voltage is removed from the MODE switch and mode selection becomes a function of the remote control through the serial interface and parallel input circuit cards.

When the MODE switch is set to CW mode, a CW enable signal (+5 V dc) is supplied to P4-9, P6-17, J8-9, J9-9, and J10-9. The CW enable signal is also applied at P5-2 to illuminate the CW status indicator on the front panel and to J6-38 to enable the CW circuits on channel A1 if A8. The CW carrier enable signal from channel A1 if A8 is applied to J2-12 on transmit audio A4 to enable the CW tone generator.

When the MODE switch is set to the AM mode, an AM enable signal (+5 V dc) is supplied to P4-7, P6-15, J8-8, J9-8, and J10-8. The AM enable signal is also applied to J6-35 to enable the AM carrier circuit and to enable the circuit that reduces the gain by 6 dB on channel A1 if A8. In addition, the MODE switch applies +5 V dc to the channel A1 CHANNEL ENABLE switch. The channel A1 CHANNEL ENABLE switch (when in the MIC position) applies a microphone select signal from P3-12 thru J12-12 to J2-15, the channel A1 microphone select circuit on transmit audio A4. The AM enable signal is also applied to P5-4 to illuminate the AM status indicator on the front panel.

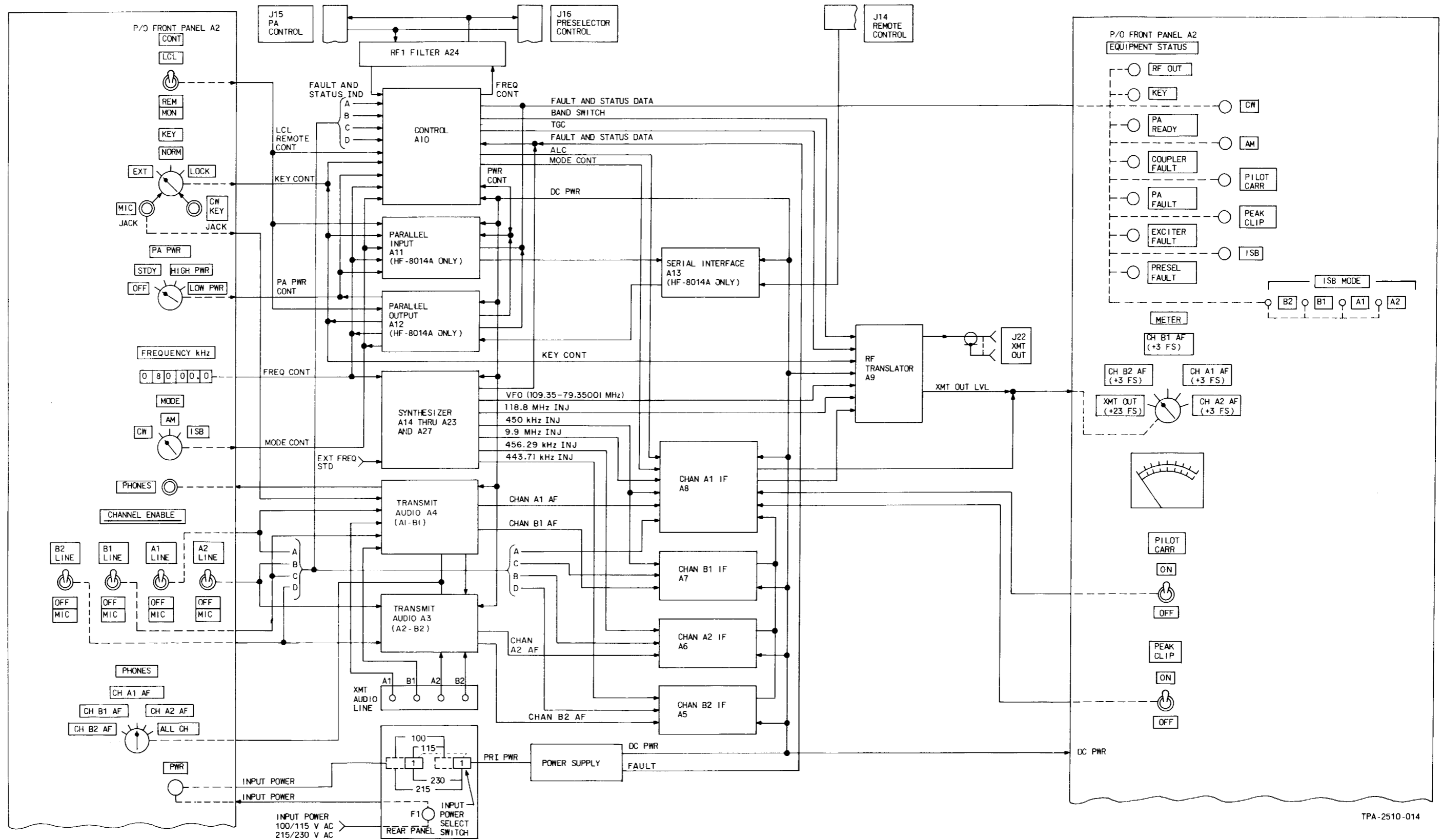

TPA-2510-014

HF-8014( ) Exciter, Block Diagram  
Figure 1



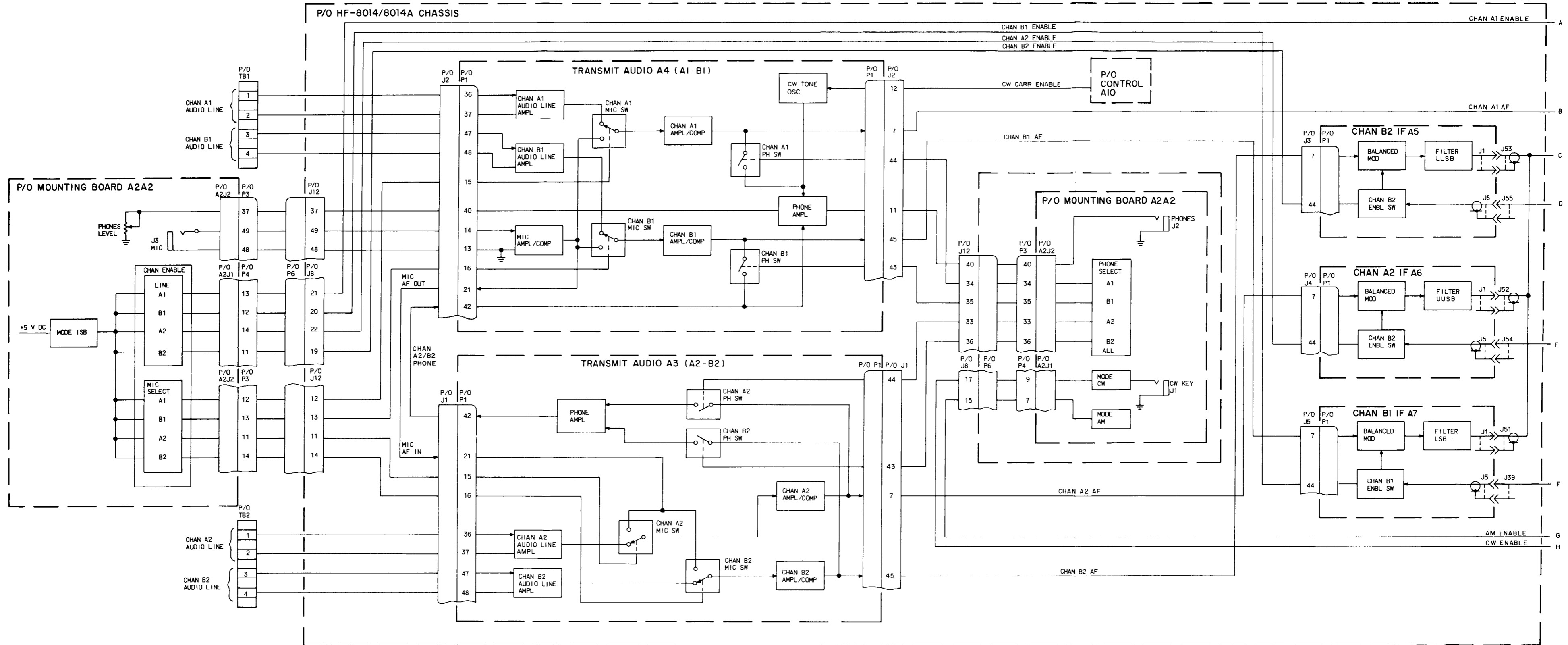

TPA-2537-025

Transmit Function, Block Diagram  
Figure 2 (Sheet 1 of 2)

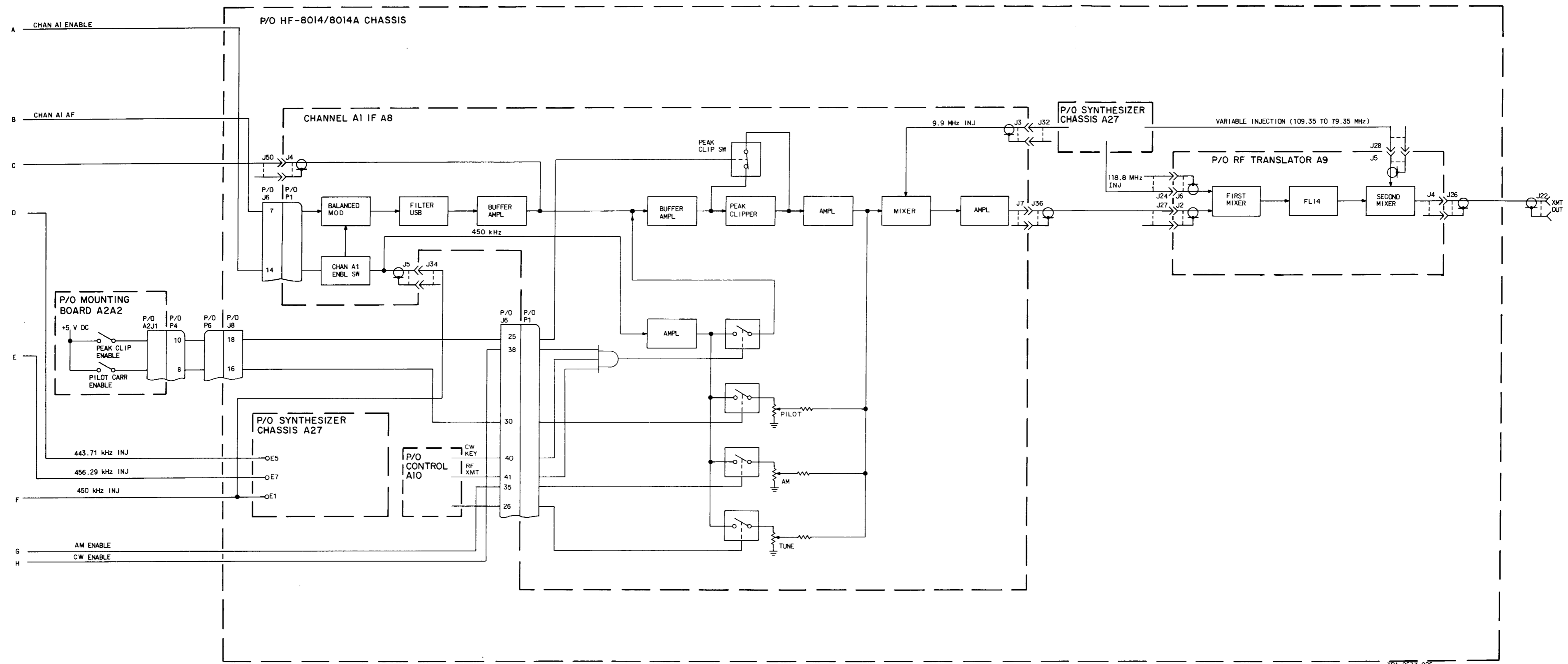

TPA-2537-025

Transmit Function, Block Diagram  
Figure 2 (Sheet 2)

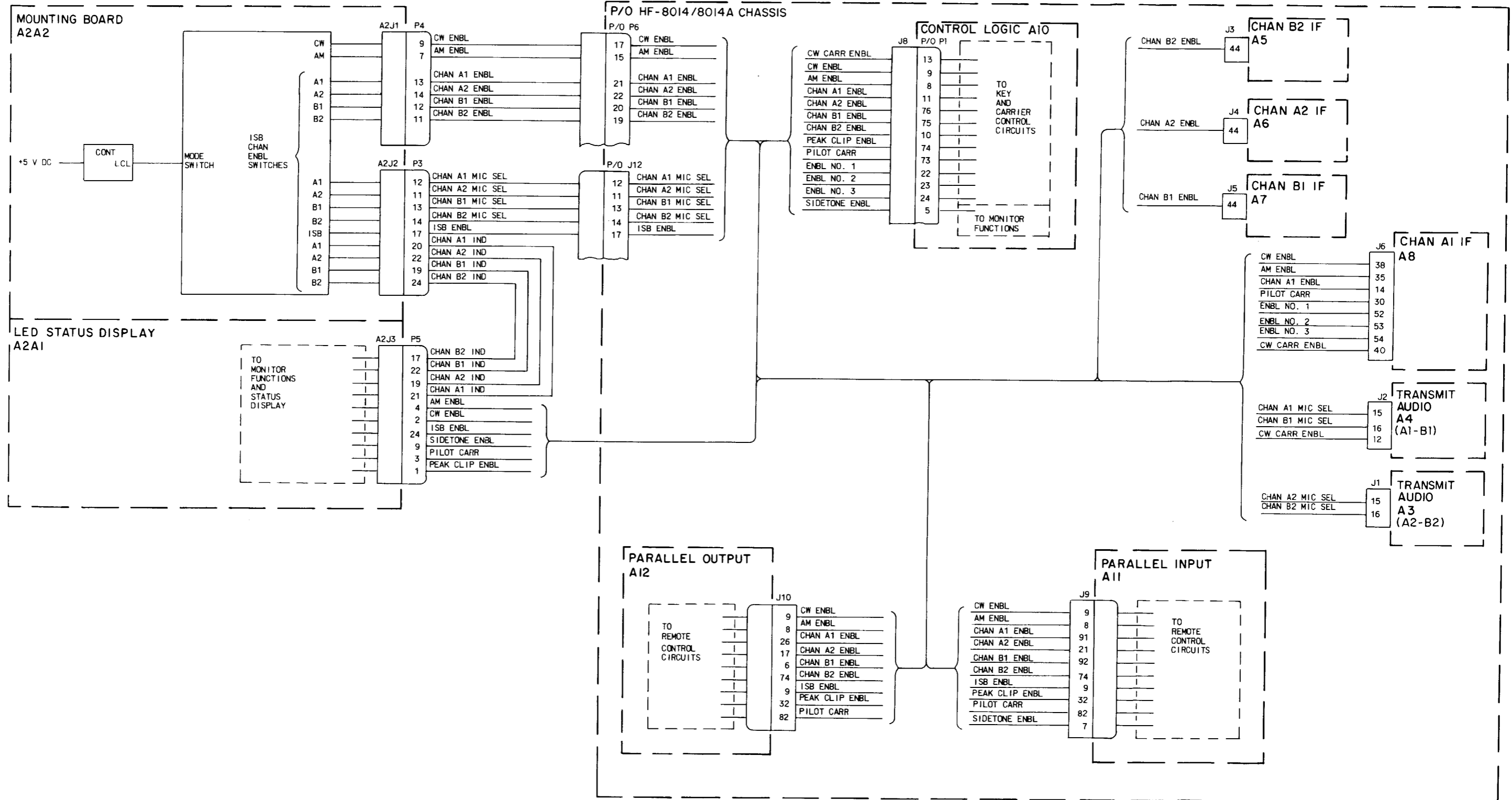

TPA-2538-014

Mode Select Function, Block Diagram  
Figure 3

When the MODE switch is set to the ISB mode, an ISB enable signal (+5 V dc) is applied to P3-17, J12-17, J9-9, and J10-9. The ISB enable signal is also applied to P5-24 to illuminate the ISB status indicator on the front panel. When the MODE switch is in the ISB position, +5 V dc is applied to the four CHANNEL ENABLE switches.

The channel A1 CHANNEL ENABLE switch supplies a +5-V dc signal in either LINE or MIC position. With channel A1 CHANNEL ENABLE switch in the MIC position, a channel A1 microphone select signal (+5 V dc) is applied to P3-12, J12-12, and J2-15 and a channel A1 enable signal (+5 V dc) is applied P4-13, P6-21, J8-11, J9-91, J10-26, and J6-14. The channel A1 microphone select signal applied at J2-15, enables the channel A1 microphone circuit on transmit audio A4 (A1-B1). In addition, the +5-V dc signal is supplied to P5-21 to illuminate the channel A1 status indicator on the front panel. With channel A1 CHANNEL ENABLE switch in the LINE position, a channel A1 enable signal (+5 V dc) is applied to P4-13, P6-21, J8-11, J9-91, J10-26, and J6-14. The absence of the channel A1 microphone select signal as was present in the MIC position, connects the channel A1 audio line input to the audio circuits in transmit audio A4 (A1-B1).

The channel A2, B1, and B2 CHANNEL ENABLE switches function in the same manner as the channel A1 CHANNEL ENABLE switch, except for the signal path (refer to figures 2, 3, and 4).

The gain of channel A1 if A8 is controlled by control A10 when operating in ISB mode. With a single channel selected, the channel A1 if operates at full gain. When any two channels are selected, enable no 1 supplies a logic 1 (+5 V dc) to J8-22 and J6-52 which reduces the gain of channel A1 if A8 by 3 dB. When any three channels are selected, enable no 2 supplies a logic 1 (+5 V dc) to J8-23 and J6-53 which reduces the gain of channel A1 if A8 by 5 dB. When all four channels are in use, enable no 3 supplies a logic 1 (+5 V dc) to J8-24 and J6-54 which reduces the gain of channel A1 if A8 by 7 dB.

Figure 4 shows a simplified diagram of the mode selection described in the preceding paragraphs.

When an external controlling device is used (HF-8014A Exciter only), the same mode and bandwidth operations apply, except the control signals are supplied as serial data to serial interface A13 and converted from serial data to parallel data in parallel output A12. The outputs of parallel output A12 are supplied to the internal circuits of the exciter.

## 2.2.2 Key and Carrier Control Circuits (Refer to figure 5.)

### 2.2.2.1 System Key, RF Transmit, and Key Indication

A system key is initiated when not inhibited and any of the following conditions are met.

- A local key and local enable signals are applied.
- A remote key is applied and a local enable signal is not applied.
- A CW enable or CW key enable is applied; and a local key, local enable, or an external key is applied.

The system key is inhibited when any of the following conditions are met.

- A 1.6- to 30.0-MHz band signal (logic 0) is supplied (bcd input below 1.6 or above 30.0 MHz).
- An exciter fault signal (logic 0) is applied.

The rf transmit and key indications (system key complements) are supplied when a system key is applied.

### 2.2.2.2 450-kHz Enable

A 450-kHz enable signal is initiated by application of power to control A10.

### 2.2.2.3 AF Transmit

The af transmit signal is initiated when a system key is applied and CW carrier enable (paragraph 2.2.2.4) or exciter tune signals are not applied.

### 2.2.2.4 CW Carrier Enable

The CW carrier enable signal is initiated when a CW enable or CW key enable signal is applied and a local key, local enable, or external key signal is applied.

### 2.2.2.5 Tune Power

A tune power signal is initiated when a system key is applied and an exciter tune signal is applied.

## 2.2.3 Audio (Refer to figure 6.)

Control of the transmit audio channels is determined by the setting of the CHANNEL ENABLE switches on the front panel. The CHANNEL ENABLE switches are 3-position switches with a center OFF position. In the OFF position, the audio circuits are

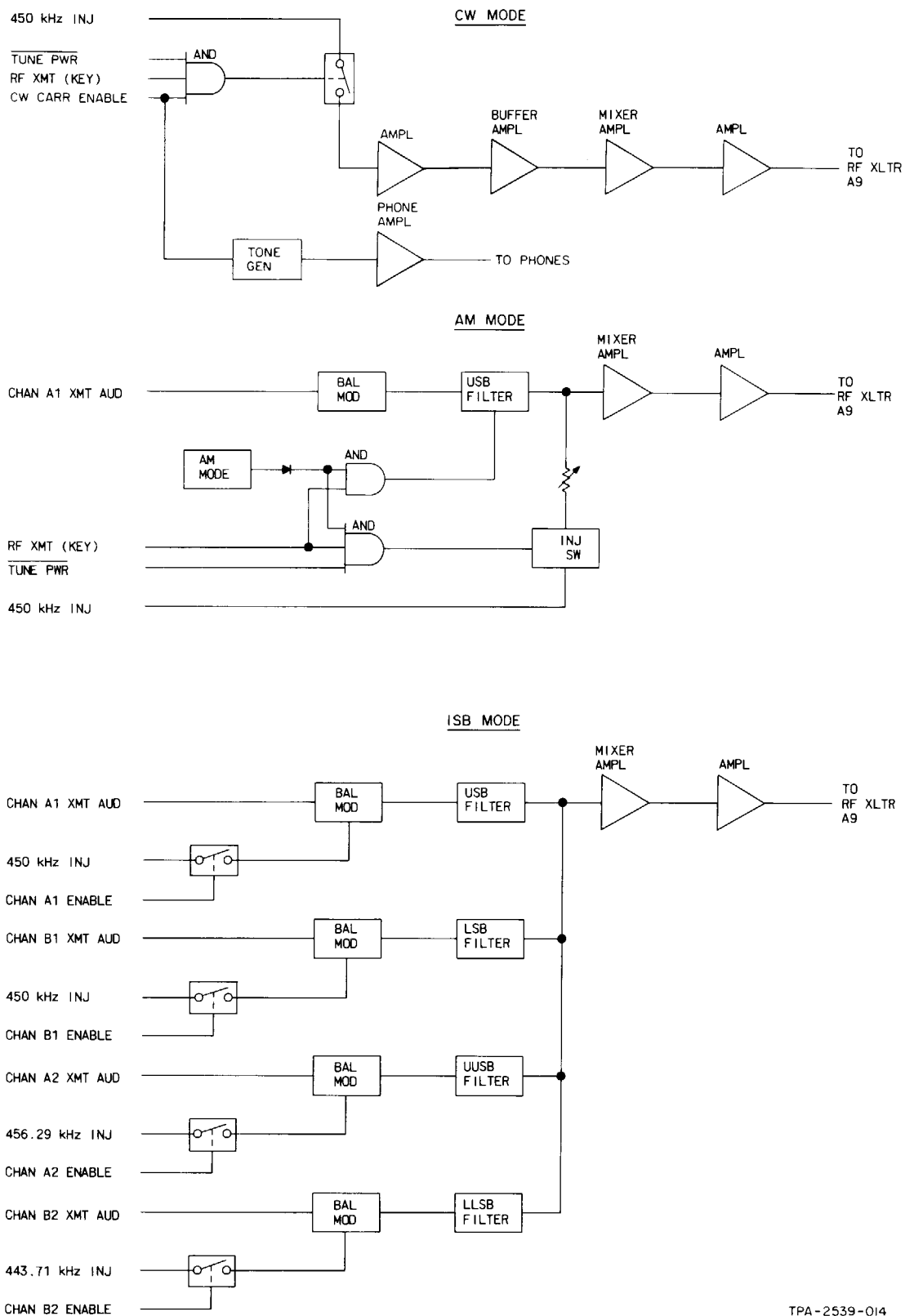

TPA-2539-014

Mode Select Function, Simplified Block Diagram  
Figure 4

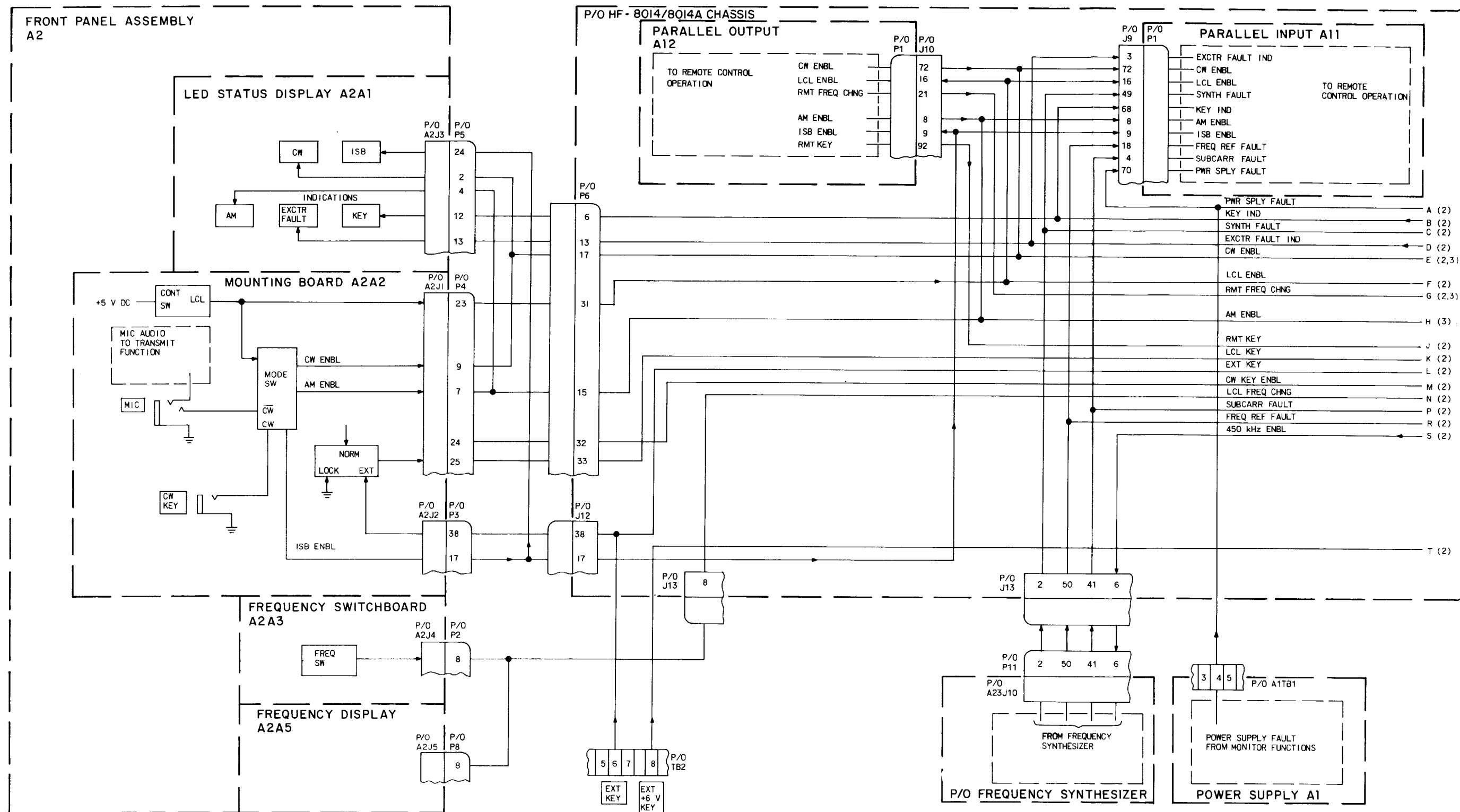

TPA-2568-034

Key and Carrier Control Functions, Block Diagram  
Figure 5 (Sheet 1 of 3)

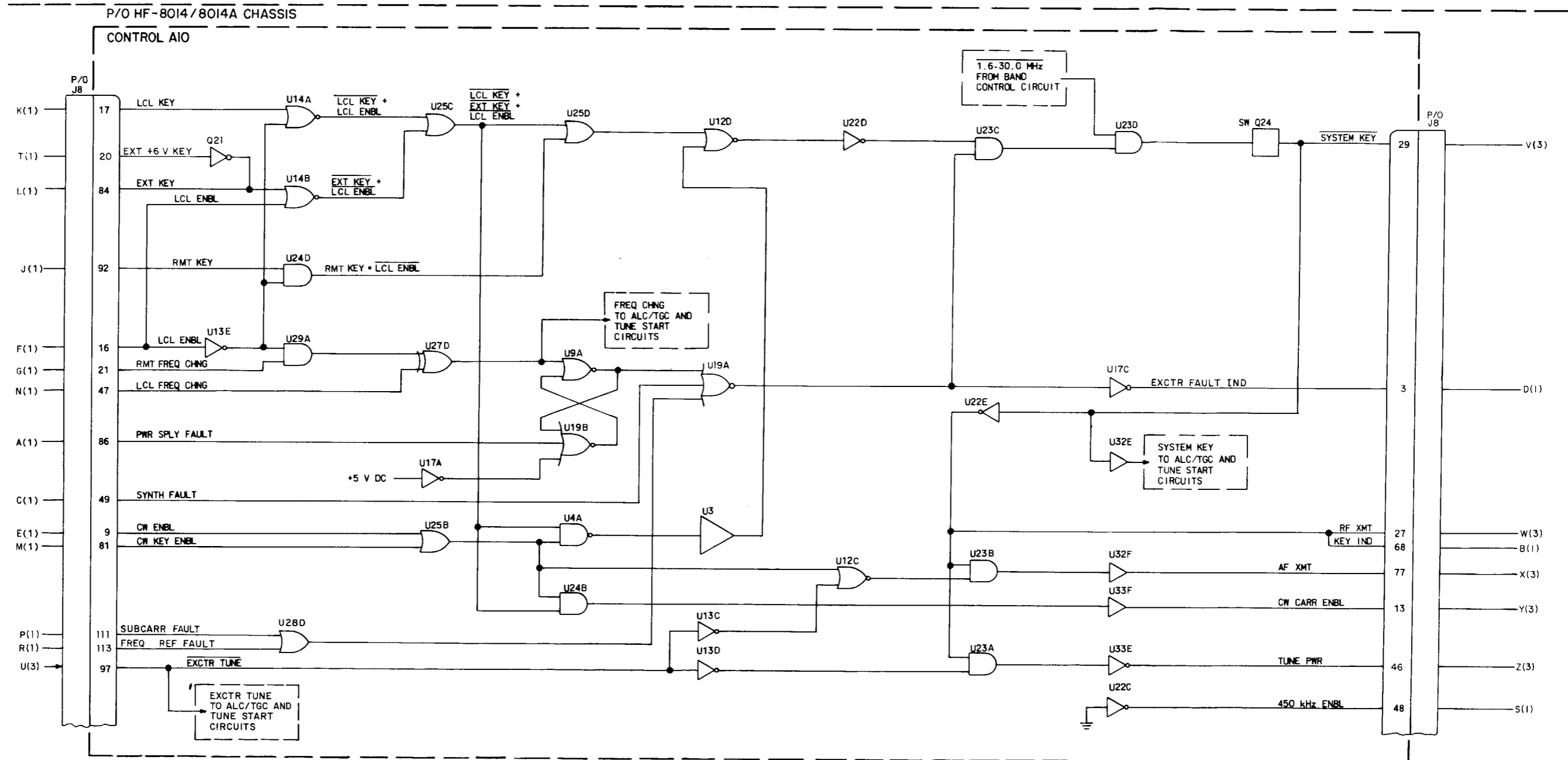

Key and Carrier Control Functions, Block Diagram  
Figure 5 (Sheet 2)

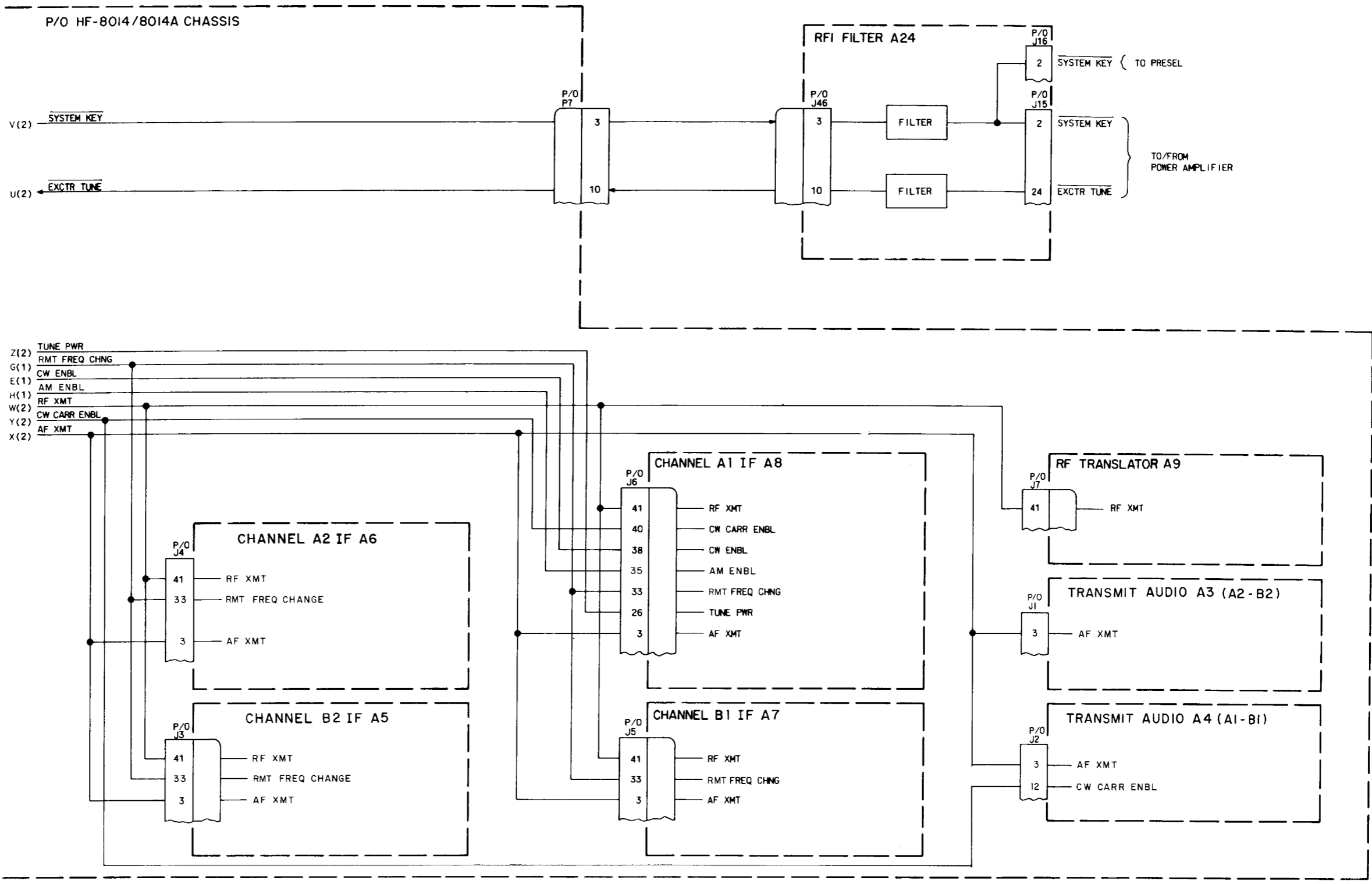

TPA-2568-034

Key and Carrier Control Functions, Block Diagram  
Figure 5 (Sheet 3)



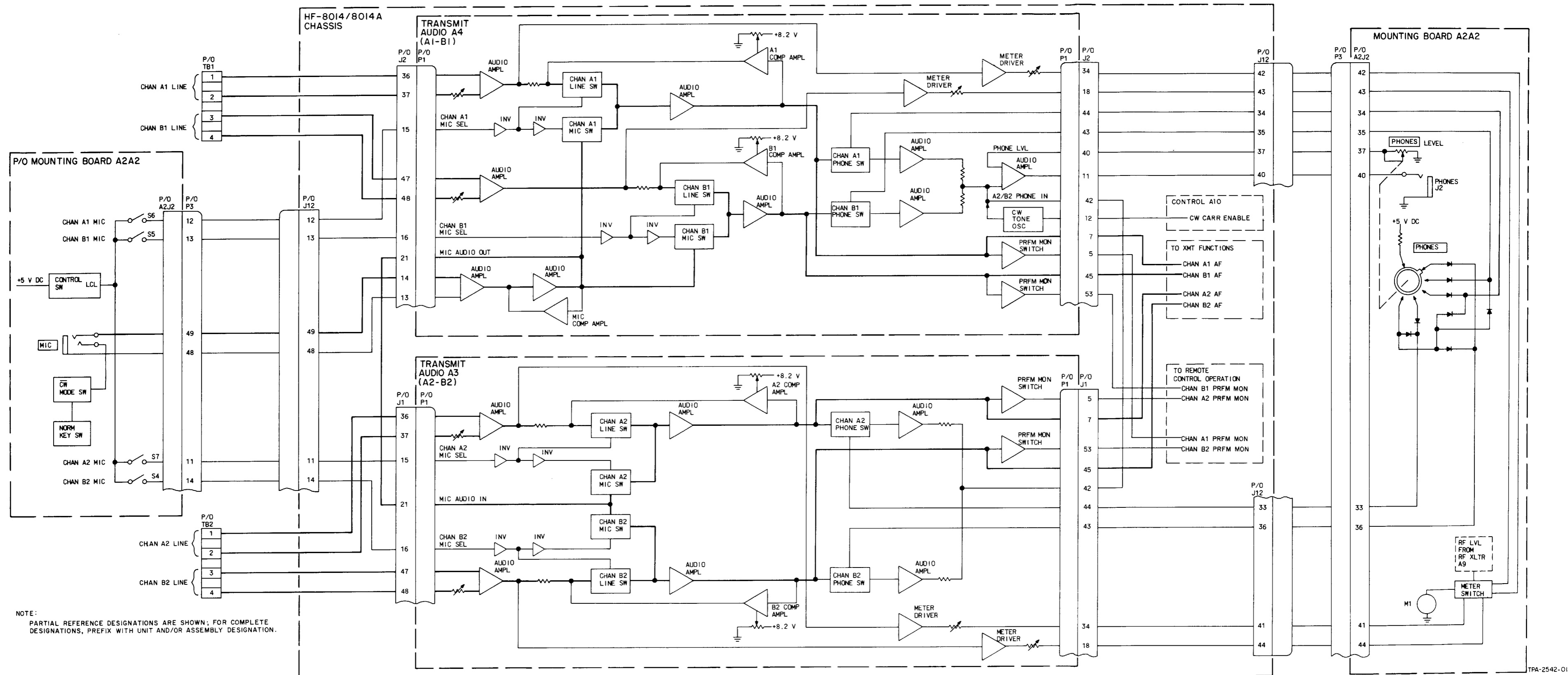

NOTE:  
PARTIAL REFERENCE DESIGNATIONS ARE SHOWN; FOR COMPLETE DESIGNATIONS, PREFIX WITH UNIT AND/OR ASSEMBLY DESIGNATION.

Audio Function, Block Diagram  
Figure 6

TPA-2542-015

disabled. When the CHANNEL ENABLE switch is placed in the MIC position, the line input is disabled and the microphone audio input is enabled. When the CHANNEL ENABLE switch is placed in the LINE position, the line input is enabled and the microphone audio input is disabled.

The enabling voltage applied through the CHANNEL ENABLE switches is applied through the front-panel CONT switch and MODE switch. When the CONT switch is in the REM position, the enabling voltage is removed and none of the microphone audio inputs are enabled and all four line inputs are enabled.

## 2.2.4 ALC/TGC and Tune Start (Refer to figure 7.)

### 2.2.4.1 ALC

The power amplifier supplies an ALC input to control the power output of the exciter and power amplifier during normal operation. The power amplifier normally does not generate ALC voltage until the rf output level is near its rated output. The greater the ALC input (more negative), the lower the exciter/power amplifier output.

The ALC input is supplied through J15-22, J46-6, P7-6, and J8-95 to the ALC amplifier in control A10. The ALC amplifier provides a dc voltage ALC output through J8-85 and J6-9 to channel A1 if A8. The ALC dc voltage is applied to pin diodes A8CR4 and A8CR5. These attenuators are located at the input to the balanced modulator A8Q7 on channel A1 if A8. When the power amplifier rf peak envelope power output tends to exceed its power rating, a higher dc voltage is applied to the ALC control lines to channel A1 if A8. The if attenuates the rf signal to the power amplifier, thus holding the rf output constant.

### 2.2.4.2 TGC

The purpose of the TGC circuit is to control the power output of the power amplifier. This is accomplished by controlling the exciter rf output level. The exciter rf output level is set during the tune cycle.

When a tune start signal (pulse) is applied, the digital-to-analog converter in control A10 is preset to minimum count which corresponds to maximum TGC output. The TGC clock oscillator then begins to decrease the TGC output voltage in small steps (256 total) until the pa TGC input applies a voltage that corresponds to half-power output. When the pa reaches its final tune stages, the TGC input changes

to allow full-power output. The change is accomplished by stepping a counter through its count range and converting the output to a dc control voltage in a digital-to-analog converter. By this technique the counter and thus the gain change stops, and the correct gain setting is remembered during normal operation after the tune cycle is completed.

The TGC input is supplied through J15-23, J46-8, P7-8, and J8-96 to the TGC differential amplifier in control A10. If the TGC input is out of the differential input tolerance range, the TGC clock oscillator is enabled and provides a clock signal through NAND and NOR control gates to the digital-to-analog converter circuit. The digital-to-analog converter counts until the TGC input is satisfied or until max/min count is reached.

When the TGC input is satisfied, the TGC differential amplifier removes the TGC clock oscillator enable signal. The clock signal is stopped, keeping the digital-to-analog converter output at the last count prior to removal of the clock.

If the digital-to-analog converter reaches max/min count, the max/min output inhibits the NAND control gate and prevents any additional clock inputs holding the digital-to-analog converter at max/min count.

The TGC output is supplied through J8-26 and J7-37 to pin diode attenuators A9CR19, A9CR20 and A9CR22, A9CR23 at the first and second mixer inputs in rf translator A9. The TGC output controls the exciter rf output which controls the rf output of the associated power amplifier.

### 2.2.4.3 Tune Start

A tune start pulse is initiated by the exciter when it is desired to tune/retune the power amplifier and/or antenna coupler. The following conditions initiate a tune start signal.

- a. Application of a local enable signal.
- b. Change of a local frequency control.
- c. Setting PA PWR switch to or from the LOW PWR position.
- d. Change of a remote frequency control when a local enable signal is not applied.

The tune start signal is a single pulse that initiates application of a maximum TGC output and supplies a TUNE START output pulse to the power amplifier through J8-99, P7-14, J46-14, and J15-26.

### **2.2.5 Frequency Control (Refer to figure 8.)**

The HF-8014( ) Exciter frequency is controlled by parallel bcd frequency inputs to the frequency synthesizer. These parallel bcd inputs are supplied directly from the front panel or from a remote control (in HF-8014A Exciter only) through serial interface A13 and parallel output A12.

Parallel bcd frequency inputs in 10-Hz steps are supplied directly from thumb-wheel switches on A2A3 through P2 and J13 to J8, J9, and P11. If remote control is used (for HF-8014A Exciter only) parallel frequency inputs are supplied directly from parallel output A12 through J10 to J8, J9, and P11.

On those exciters equipped with frequency display, the bcd frequency code from the thumb-wheel switches is applied to frequency display A2A5. The bcd information drives the LED indicators which provide a visual indication of the operating frequency. In the remote mode (HF-8014A Exciter only), the bcd frequency information is supplied to the frequency display from parallel output A12. In this manner the frequency display indicates the frequency selected at the remote control.

Parallel 100-kHz to 20-MHz bcd inputs supplied to J8 are also supplied through buffer/drivers in control A10, through J8 and P7 to J46 through rfi filters in rfi filter A24 to power amplifier control connector J15.

Parallel bcd frequency inputs are supplied to the synthesizer through P11 to the appropriate decade. The 1-Hz bcd inputs are applied through A27U4 to synthesizer end decade A17 (1-Hz tuning only); the 10-Hz bcd inputs are applied through A27J5 to synthesizer 10-Hz decade A18 (10-Hz tuning only); the 100-Hz bcd inputs are applied through A27J6 to the synthesizer 100-Hz decade A19; the 1-kHz bcd inputs are applied through A27J7 to synthesizer 1-kHz decade A20; the 10-kHz bcd inputs are applied through A27J8 to synthesizer 10-kHz decade A21; the 100-kHz bcd inputs are applied through A27J9 to synthesizer 100-kHz decade A22; and the 1- and 10-MHz bcd inputs are applied through A27J10 to synthesizer output A23.

Refer to paragraph 2.4 for frequency synthesizer operation.

### **2.3 Remote Control Operation (HF-8014A Only)**

The HF-8093 Exciter Control unit is designed as a companion to the HF-8014A Exciter. This exciter control provides all the functions required to remotely

control and monitor the operation of the exciter. The exciter control generates the serial data required to control the exciter and accepts serial monitor data from the exciter for display of the current operating status. When remote processor control of the exciter is desired, the processor must generate the serial data characters required to control the exciter and interpret the monitor data from the exciter. In processor control applications, the exciter control interface requirements are similar to a serial data terminal in operation, with formatted messages from the processor controlling operation of the exciter and messages from the exciter to the processor reporting operating status of the exciter. An RS-232C serial, asynchronous, input/output interface capability is required in the processor for remote control of the exciter.

The following paragraphs describe the characteristics applicable to remote control of the exciter and the operation of the remote control circuits in the exciter.

#### **2.3.1 General**

Two methods of serial data signaling are available in the HF-8014A Exciter. Each method is switch selectable on the serial interface card. The two methods are frequency-shift keyed audio tones (FSK) and RS-232C data logic levels. In conjunction with selection of the RS-232C signaling, switching is available to invert the polarity of the RS-232C data for compatibility with the logic polarity and voltage levels defined in MIL-STD-188C.

When the FSK methods is selected, only one exciter may be controlled and monitored by a single HF-8093 Exciter Control. When the RS-232C logic level signaling method is selected, up to 16 individually addressable exciters may be controlled and monitored by a single HF-8093 Exciter Control. Up to 32 individually addressable exciters may be controlled and monitored by a processor. The RS-232C control can be by direct connection to the exciter control or processor, or by transmission using data modems over longer distances.

Two separate sets of data lines are used for serial control of the exciter. One set, called the control bus, is used to receive command data. The other set, called the monitor bus, is used to transmit status information. When using FSK signaling, the control and monitor buses are balanced 600-ohm audio lines. When strapped for RS-232C signaling, the control and monitor buses are unbalanced lines to ground. The data transmission rate on the control and monitor

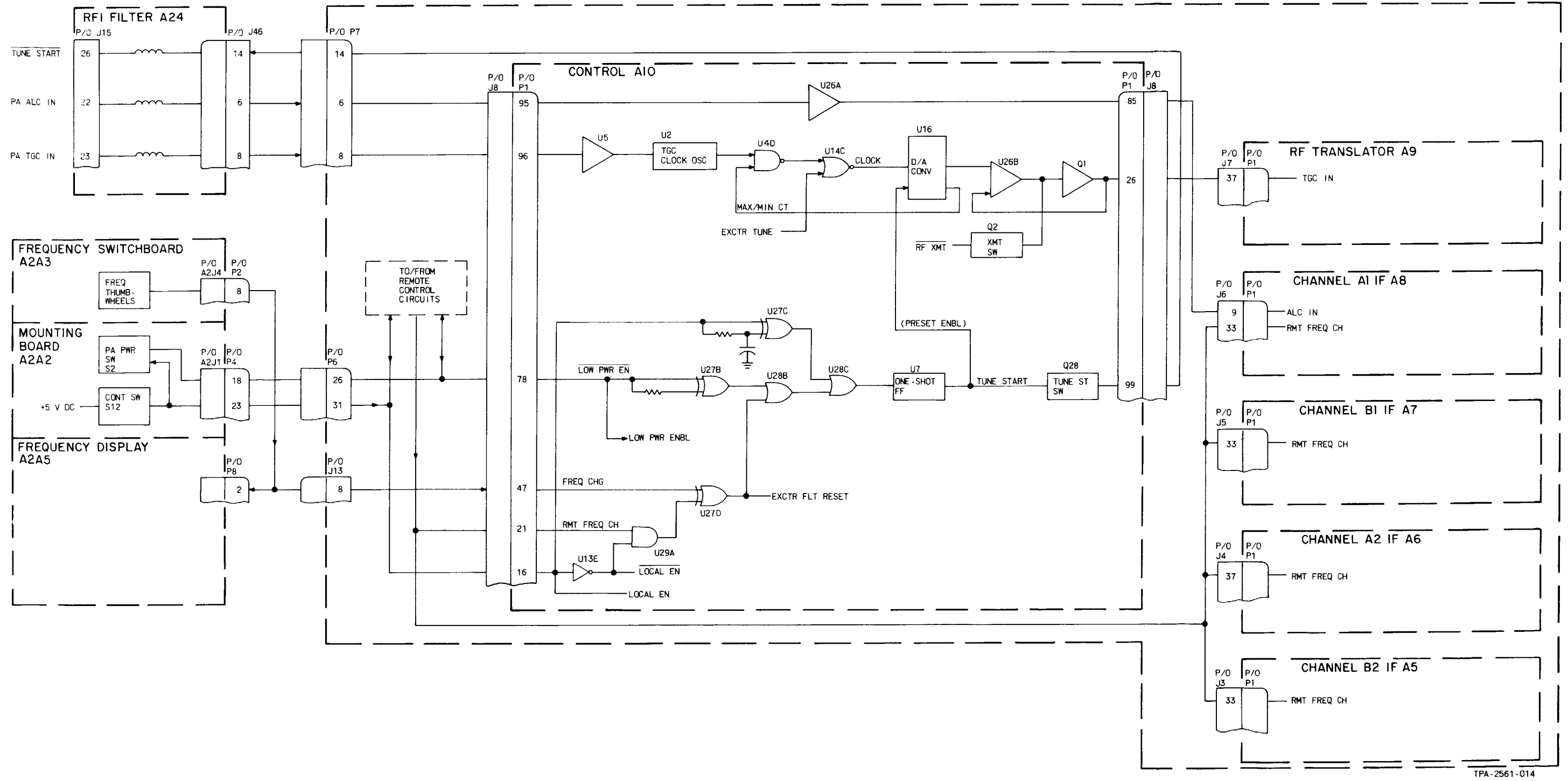

TPA-2561-014

ALC/TGC and Tune Start Functions, Block Diagram  
Figure 7

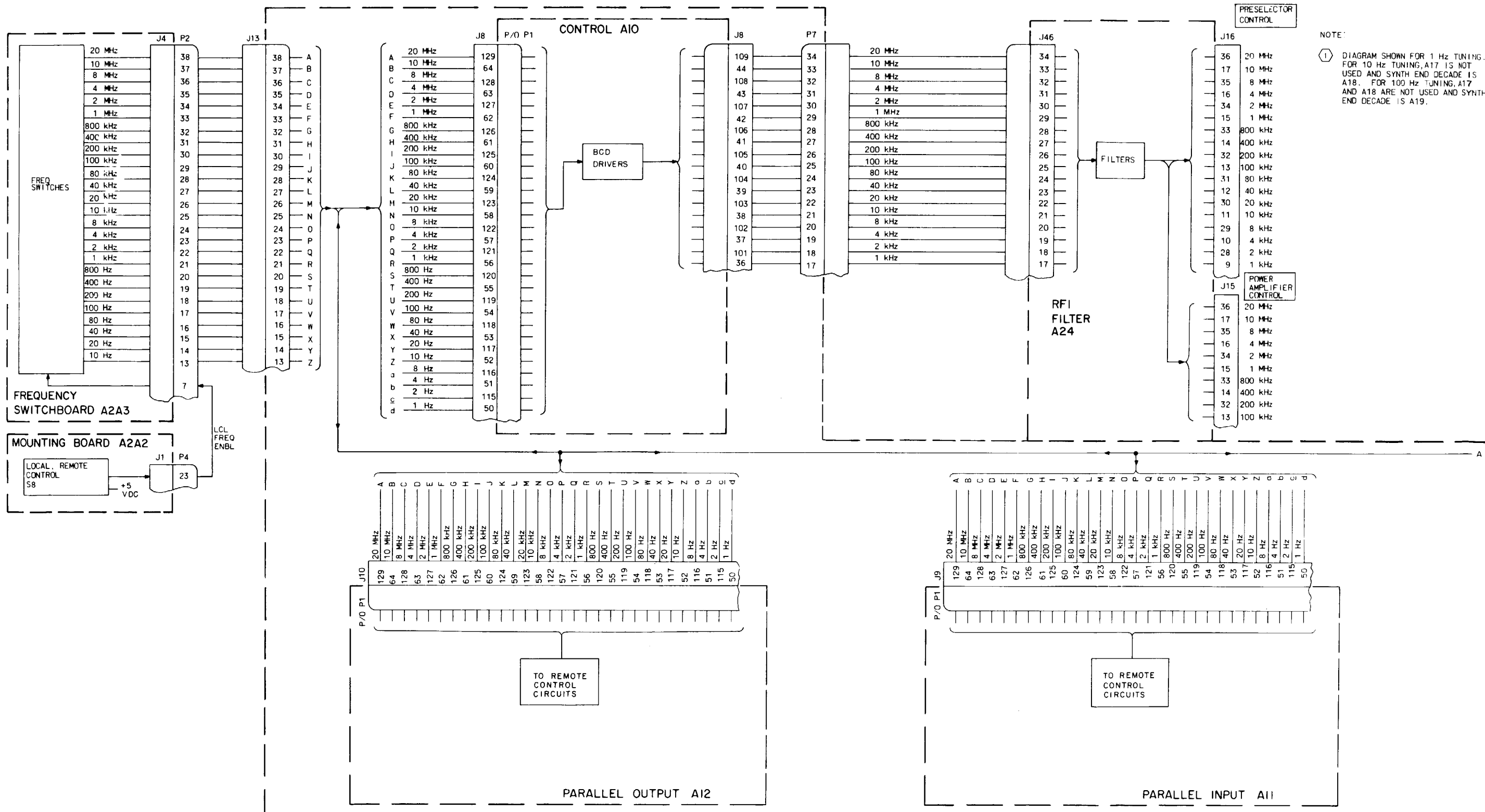

NOTE:  
 ① DIAGRAM SHOWN FOR 1 Hz TUNING. FOR 10 Hz TUNING, A17 IS NOT USED AND SYNTH END DECADE IS A18. FOR 100 Hz TUNING, A17 AND A18 ARE NOT USED AND SYNTH END DECADE IS A19.

Frequency Control Function, Block Diagram Figure 8 (Sheet 1 of 2)

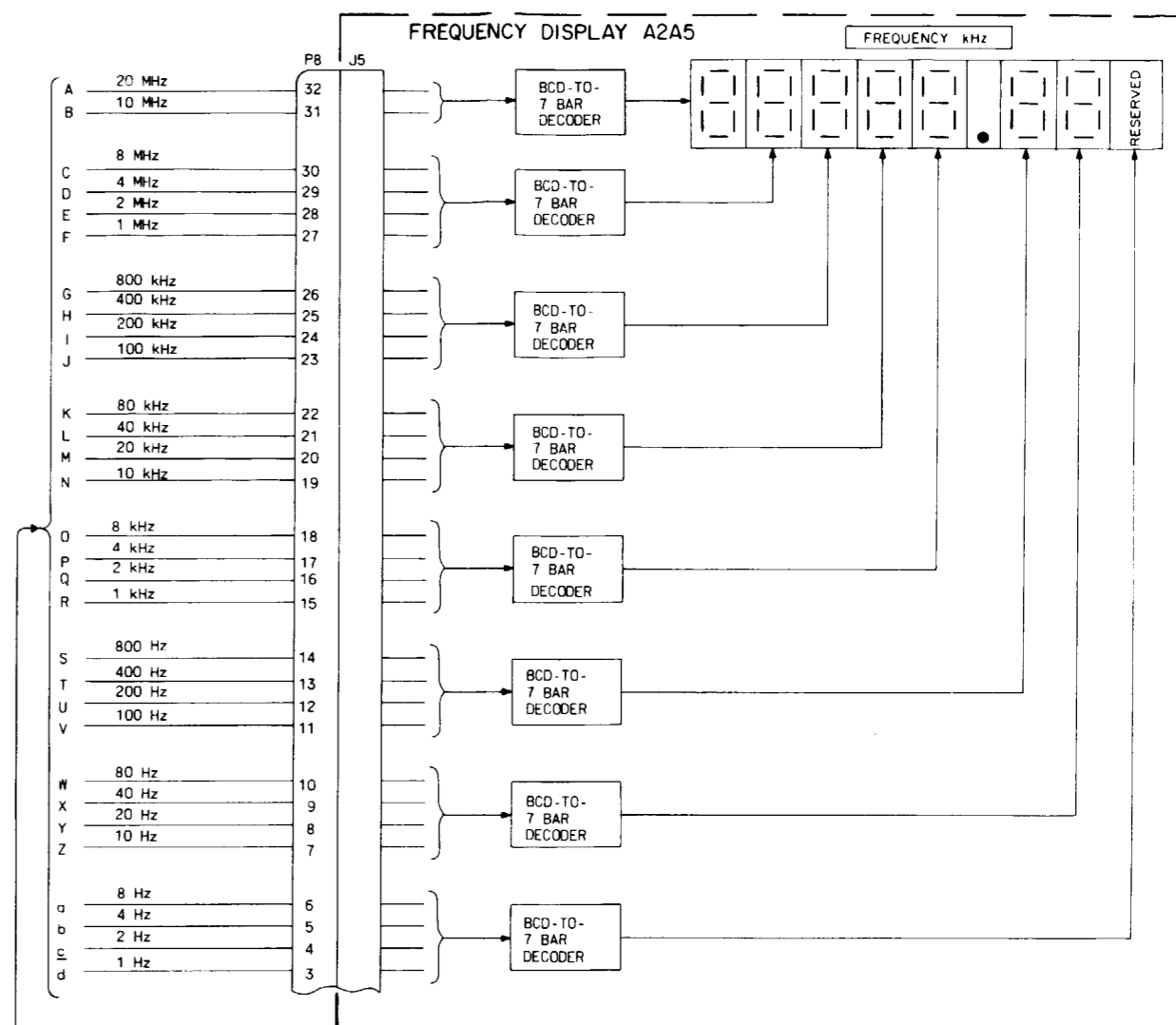
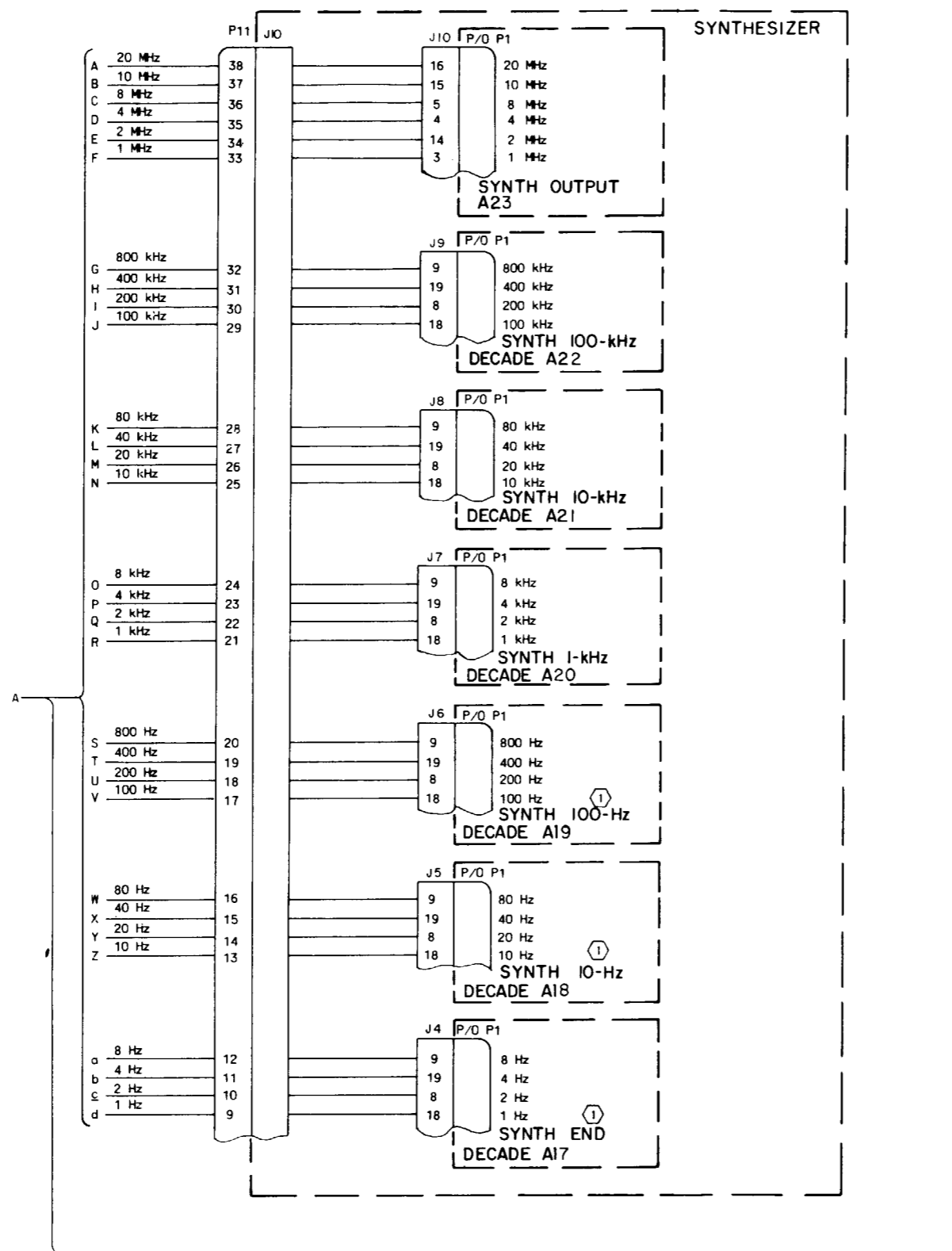

Frequency Control Function, Block Diagram  
Figure 8 (Sheet 2)

buses are switch selectable on serial interface A13. Transmission rates are 75, 109, 150, 300, 600, 1200, 2400, 4800, 9600, and 19 200 bauds. The usable data rates for the FSK signaling method are limited to not more than 600 bauds. Each remote exciter must be set for the same data rate and parity as the associated exciter control or processor.

Data transmitted and received on the control and monitor buses is serial, asynchronous, and organized in one of two formats, ASCII or 8-bit character. In the ASCII format, the characters are made up of 9, 10, or 11 bits, consisting of one start bit, seven data bits, one parity bit (optional) and one or two (optional) stop bits, in that order. The ASCII characters are then organized into 13 character words. In the 8-bit character format, the characters are made up of 11 bits, consisting of one start bit, eight data bits, one parity bit, and one stop bit, in that order. The 8-bit characters are then formed into 5 character words. Control data bits are determined by settings of the front panel switches and controls on the exciter control, or by program control for processor control applications. Monitor data bits are determined by the current operational status of the exciter.

Except for those monitor bits that have no corresponding control functions (such as fault bits and performance monitoring bits), the control and monitor words have identical data formats. The formats are explained in detail in paragraphs 4.3.1 and 4.3.2 of the operation section of this manual.

### **2.3.2 Exciter Serial Control Operation**

#### **2.3.2.1 Control Inputs (Refer to figure 9.)**

Control data signals generated by the HF-8093 Exciter Control or processor are applied to the exciter as control information. These control signals are transferred over the control bus in serial format. If the exciter CONT switch is in the REM position, the serial information received controls the operation of the exciter.

Control data is applied to serial interface A13. Word and status information is decoded from the control data and is used to determine strobe address information. The control data is then applied to the data input of four word serial-to-parallel converters on parallel output A12. Each serial-to-parallel converter is enabled before it accepts and processes the control data. This occurs when the strobe address input is decoded and an enable signal is generated by the word enable circuit.

The serial-to-parallel converters decode the serial input information and convert it to parallel output levels. These outputs provide all control signals necessary to control the exciter remotely. These outputs are also supplied to parallel input A11 where they are processed and returned to the exciter control or processor as monitor data. This provides an indication on the front panel of the exciter control or to the processor of the control information received by the exciter. When the exciter CONT switch is in the LCL or MON position, the register outputs of parallel output A12 are disabled, and the internal parallel control lines are controlled by the exciter front panel controls.

#### **2.3.2.2 Monitor Outputs (Refer to figure 9.)**

With the exciter CONT switch in the REM position, monitor signals indicating frequency, power level, mode, and related control and enable signals are applied, in parallel, from parallel output A12 to parallel input A11 for processing and application to serial interface A13. Fault and performance monitor indications are applied from appropriate areas of the exciter to parallel input A11 for processing and application to serial interface A13. Serial interface A13 output to the exciter control is a series of monitor words in serial format. (The monitor word format is identical to the control word format.)

Four separate words are required to supply a complete status report to the exciter control. These four words are independent of each other, thus can be transmitted at any time and in any sequence.

Monitor (and control) word timing is accomplished by a crystal-controlled oscillator on serial interface A13. A divider reduces the frequency to the desired values. Switches permit selection of the baud rate for clock inputs to the various circuits. Selection is from 75, 109, 150, 300, 600, 1200, 2400, 4800, 9600, and 19,200 bps.

Monitor information (performance monitors and faults) from the exciter cards is fed to multiplexers on parallel input A11. This monitor data is clocked out through serial interface A13 which shifts the serial data through the FSK keyer or RS-232C driver circuit to the external monitor bus and exciter control.

With the exciter CONT switch in the LCL or MON position, operation of the monitor circuits is identical to that described above. However, the outputs of the storage registers on parallel output A12 (which store the exciter control data) are disabled and internal control lines (mode, frequency, bandwidth, etc) are

controlled by the exciter front panel controls. Thus, the exciter front panel controls determine exciter operation and their control signals are applied to parallel input A11 for processing and application to the exciter control as monitor data. Because of this the monitor data from the exciter always contains the applied operational status of the exciter, whether it is operated locally or remotely.

The LCL and MON positions of the CONT switch are identical except that in the LCL position the local control bit of the monitor data is set to logic 1. In the MON position both the local control bit and the monitor bit of the monitor data are set to logic 1. The monitor bit is used as a flag in processor control applications, indicating that some programmed action needs to be initiated by the processor control.

## **2.4 Frequency Synthesizer**

### **2.4.1 General (Refer to figure 10.)**

The frequency synthesizer used in the HF-8014( ) Exciter can be accurately tuned in 1-, 10-, or 100-Hz steps. The tuning increment is determined by the use and placement of the associated frequency decade circuit cards. The frequency synthesizer uses a 9.9-MHz txco (temperature-compensated crystal oscillator) as a base for generating the required synthesizer frequencies. Using dividers and multipliers, the synthesizer produces the following fixed frequencies.

- a. 9.9-MHz injection frequency
- b. 118.8-MHz injection frequency
- c. 100-kHz synthesizer reference frequency
- d. 450-kHz USB and LSB injection frequency
- e. 456.29-kHz UUSB injection frequency
- f. 443.71-kHz LLSB injection frequency

Using the 100-kHz synthesizer reference frequency and the associated decades, the variable injection frequency for the selected output frequency is generated. The variable injection frequency is 109.350000 to 79.350001 MHz (the higher the selected output frequency, the lower the variable injection frequency). Note that figure 10 shows the synthesizer complement for 1-, 10-, and 100-Hz tuning.

### **2.4.2 Synthesizer Reference (Refer to figure 11.)**

Synthesizer reference A16 uses a 9.9-MHz txco as a base for generating the required synthesizer frequencies. When used with an external reference, the 9.9-MHz txco is supplied with a tracking voltage generated by the 100-kHz reference signal and the ex-

ternal frequency standard. When not used with the external reference, an internal temperature compensation network is used to maintain a constant frequency output from the txco.

The 9.9-MHz txco output is supplied through an output amplifier and used as 9.9-MHz fixed injection output and applied to a times-12 circuit that produces a 118.8-MHz fixed injection input.

The 9.9-MHz txco output is applied to a divide-by-11 circuit that produces a 900-kHz base frequency. The 900-kHz base frequency is applied to a divide-by-2 circuit that produces a 450-kHz USB and LSB injection frequency. The 900-kHz base frequency is also applied to a divide-by-9 circuit that produces two 100-kHz reference outputs. The 100-kHz reference frequency outputs are applied to each of the synthesizer decades as a reference for variable injection frequency generation and to synthesizer subcarrier generator A15. In addition, the 450-kHz signal is applied to synthesizer subcarrier generator A15.

Frequency standard switch A30 (optional) applies the external reference signal to synthesizer reference A16. If the external standard malfunctions or the signal is interrupted, frequency standard switch A30 automatically switches to the internal standard, preventing loss of service.

### **2.4.3 Synthesizer Subcarrier Generator (Refer to figure 11.)**

Synthesizer subcarrier generator A15 uses three phase-locked loops to produce output frequencies of 456.29 kHz and 443.71 kHz. These frequencies are used in the exciter when using channel A2 (upper-upper sideband) and channel B2 (lower-lower sideband) modes of operation.

Synthesizer subcarrier generator A15 receives input reference signals of 450-kHz and 100-kHz in addition to the 450-kHz enable signal. The output signals are the 456.29-kHz injection signal, the 443.71-kHz injection signal, and a synthesizer subcarrier generator status signal.

The 456.29 kHz phase-locked loop consists of loop mixer Q5, squaring amplifier U6D, E, F; phase/frequency detector U1, U2, U3; integrator-filter U4A, B; and vco-buffer Q1, Q2, Q3.

The 443.71-kHz phase-locked loop consists of loop mixer Q7; squaring amplifier U6A, B, C; phase/frequency detector U17, U18, U19; integrator-filter U20A, B; and vco-buffer Q8, Q9, Q10.



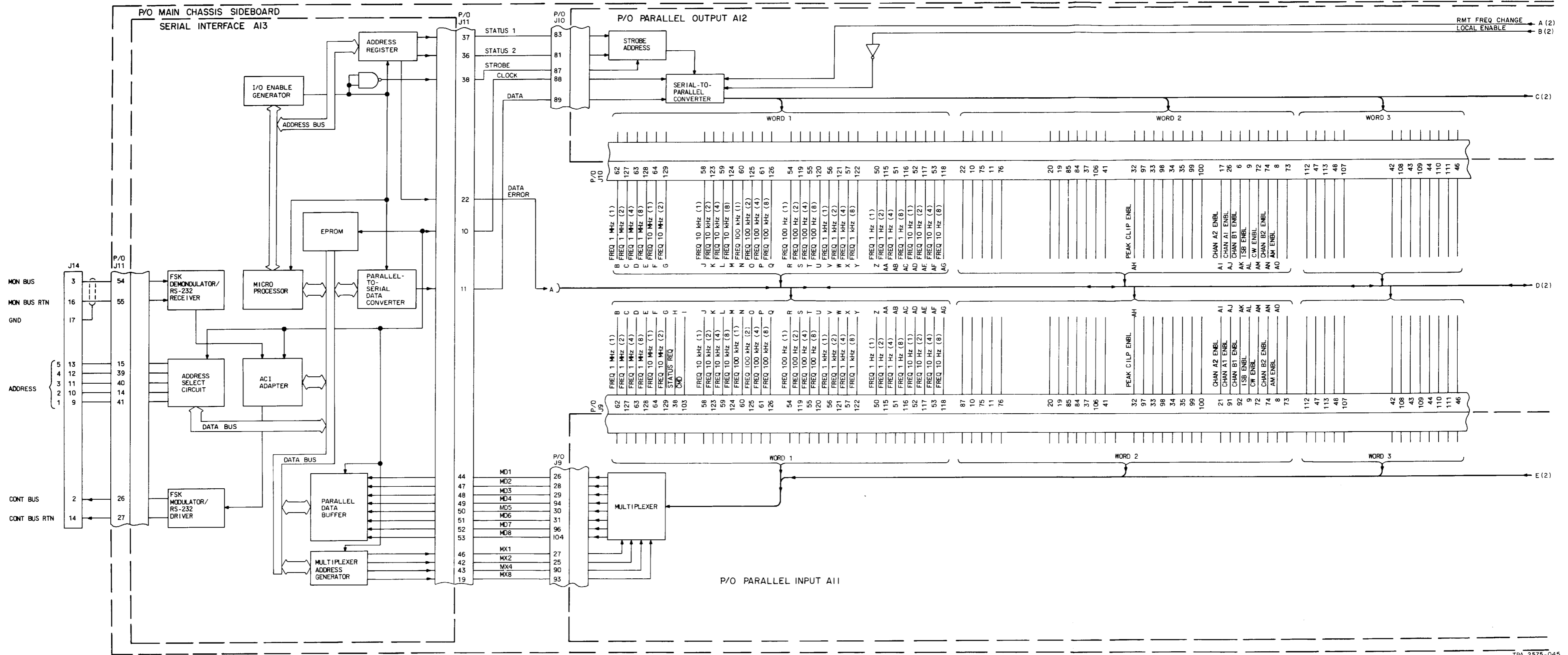

TPA-2575-045

Remote Control Function, Block Diagram  
Figure 9 (Sheet 1 of 4)

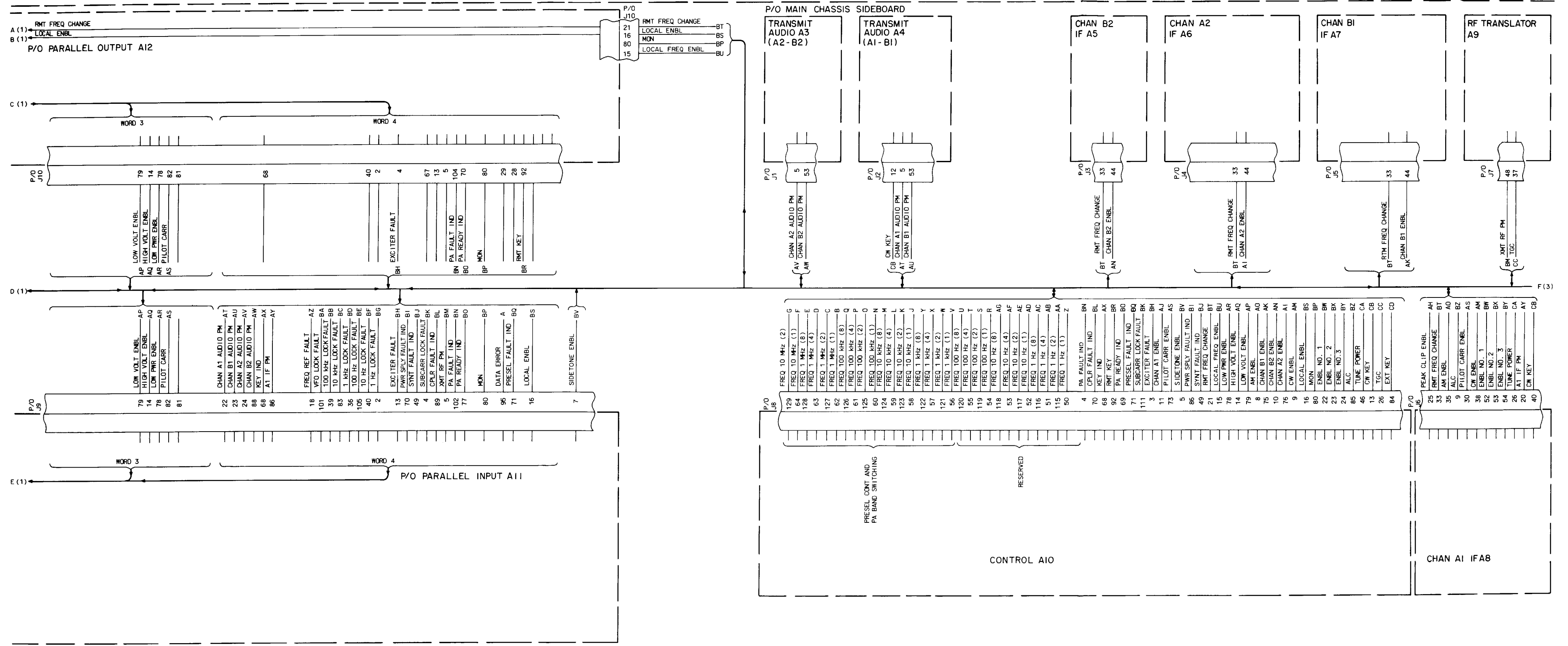

Remote Control Function, Block Diagram  
Figure 9 (Sheet 2)

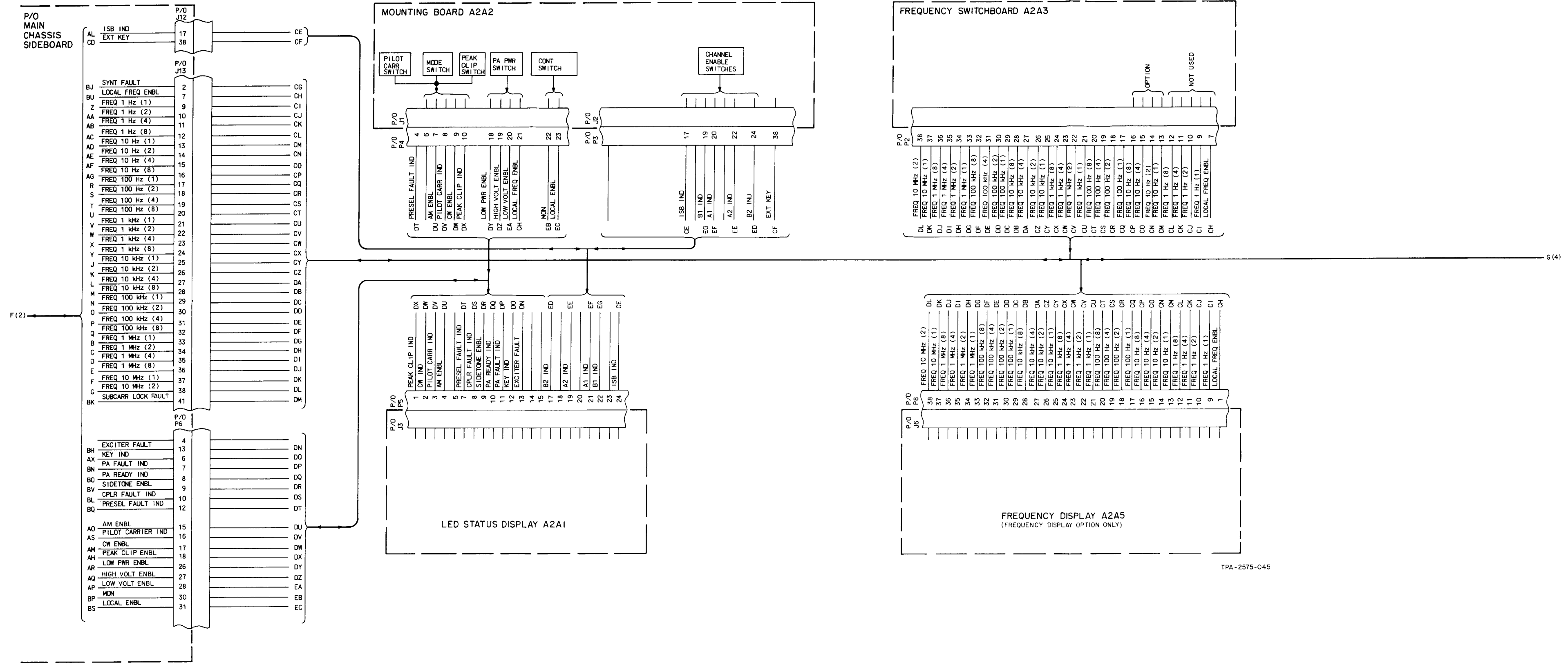

TPA-2575-045

Remote Control Function, Block Diagram  
Figure 9 (Sheet 3)

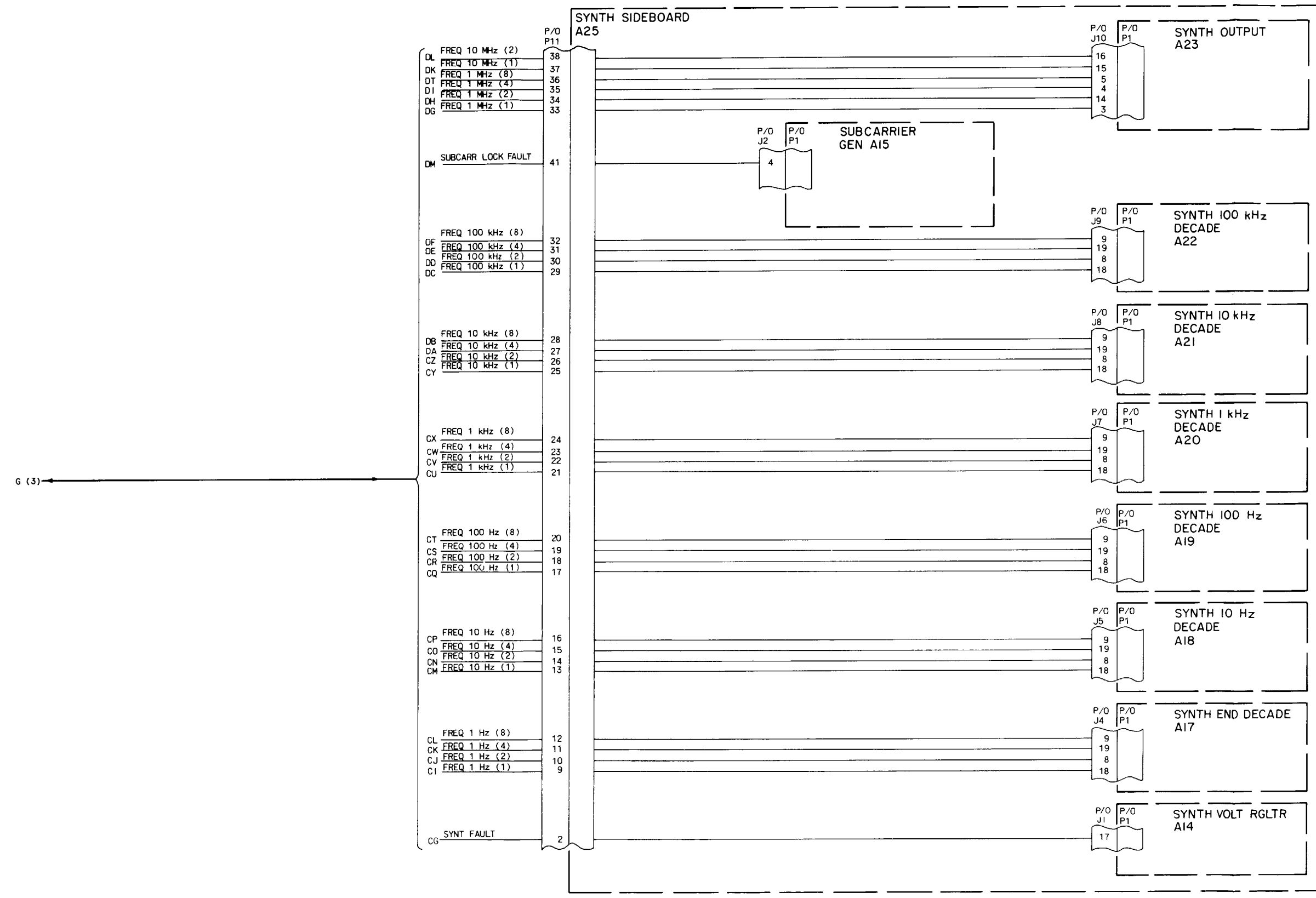

NOTES:

- 1 SYNTHESIZER SHOWN IS OPTIONAL 1 Hz TUNING. 10 Hz TUNING-A16 IS NOT INSTALLED AND A17 IS SYNTHESIZER END DECADE 635-0657-001. 100 Hz TUNING-A16 AND A17 ARE NOT INSTALLED AND A18 IS SYNTHESIZER END DECADE 635-0657-001. THIS IN NORMAL EXCITER AND RECEIVER-EXCITER CONFIGURATION.
- 2 NONSTANDARD ABBREVIATIONS:  
 PM-PERFORMANCE MONITOR  
 SYNT-SYNTHESIZER

TPA-2575-045

Remote Control Function, Block Diagram  
 Figure 9 (Sheet 4)

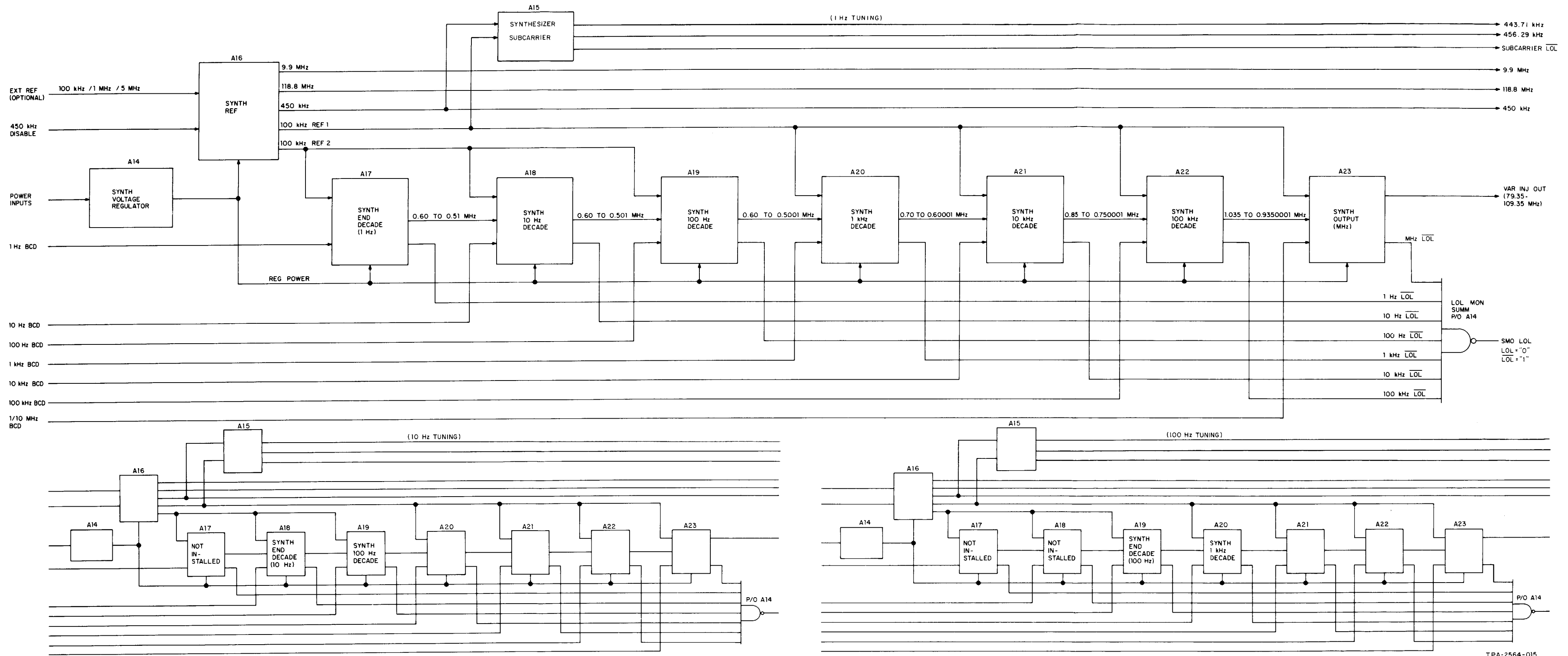

TPA-2564-015

Frequency Synthesizer, Simplified Block Diagram  
Figure 10

The 6.29-kHz phase-locked loop consists of divide-by-100 circuit U7, U13; phase/frequency detector U8, U9, U10; divide-by-629 circuit U15, U16; integrator-filter U11A; 629-kHz vco U12 and logic converter Q4.

#### 2.4.4 Synthesizer End Decade (Refer to figure 11.)

The synthesizer end decade receives bcd inputs and a fixed 100-kHz reference signal and provides a 0.60- to 0.51-MHz variable reference output to the next decade step.

The synthesizer end decade can be used as the 1-, 10-, or 100-Hz decade to provide the appropriate reference frequency to the next decade in the synthesizer. As implied by its name, it is the end decade; that is, if used as a 1-Hz decade it provides 1-Hz tuning (accuracy), if used as a 10-Hz decade it provides 10-Hz tuning (accuracy), and if used as a 100-Hz decade it provides 100-Hz tuning (accuracy).

The synthesizer end decade contains a phase-lock loop consisting of a phase/frequency discriminator, variable vco, variable divider, and a lock detector. The 100-kHz reference signal is applied to the phase/frequency discriminator where it is compared with the 100-kHz signal from the variable divider. The phase/frequency discriminator develops a tracking voltage output (based on the phase/frequency difference of the 100-kHz signals). The tracking voltage drives the variable vco to the frequency as determined by the bcd input (programmed division ratio of variable divider).

The variable vco signal is divided (division ratio of the variable divider) and applied as 100-kHz variable reference to the phase/frequency discriminator. When the inputs to the phase/frequency discriminator are the same frequency and in phase, a lock signal output is supplied.

The variable vco signal is applied to the fixed divide-by-10 output circuit and the 0.60- to 0.51-MHz end decade output signal is supplied to the next decade step.

#### 2.4.5 Synthesizer Decades (Refer to figure 11.)

The synthesizer decade bcd inputs, a fixed 100-kHz reference signal, and a variable high reference signal, and provides a variable reference signal to the next decade step. Refer to table 1 for the input/output difference of the synthesizer decades.

The synthesizer decades differ only in strapping and vco coils. These differences result in the different input and output frequencies as shown in table 1.

These synthesizer decades can be used as the 10- and 100-Hz decades and are used on the 1-, 10-, and 100-kHz decades to provide the appropriate reference frequency for the next decade in the synthesizer. For 1-Hz tuning, two 100/10-Hz decades are used, one as the 10-Hz decade and one as the 100-Hz decade. For 10-Hz tuning, one 100/10-Hz decade is used as the 100-Hz decade. For 100-Hz tuning, no 100/10-Hz decade is used.

The synthesizer decade contains two phase-lock loops. The translator phase-lock loop consists of a phase/frequency discriminator, variable vco, variable divider, and a lock detector. The 100-kHz reference signal is applied to the phase/frequency discriminator where it is compared with the 100-kHz signal from the variable divider. The phase/frequency discriminator develops a tracking voltage output based on the phase/frequency difference of the 100-kHz signals. The tracking voltage drives the variable vco to the frequency, as determined by the bcd input (programmed division ratio of variable divider). The tracking voltage is also applied as a reference voltage to the variable vco in the output phase-lock loop. The variable vco signal output in the translator phase-lock loop is applied to the mixer in the output phase-lock loop.

The variable vco signal output in the translator phase-lock loop is also divided (division ratio of the variable divider) and applied as 100-kHz variable reference to the phase/frequency discriminator. When the inputs to the phase/frequency discriminator are the same frequency and in phase, a translator lock signal output is supplied.

The output phase-lock loop consists of a phase/frequency discriminator, variable vco, mixer and squaring amplifier, and a lock detector. A high reference

Table 1. Decade Versus Input/Output Frequencies.

DECADE	HI REF INPUT FREQ (MHz)	HI REF OUTPUT FREQ (MHz)
100 kHz	0.85 to 0.750001	1.035 to 0.935001
10 kHz	0.70 to 0.60001	0.85 to 0.750001
1 kHz	0.60 to 0.5001	0.70 to 0.60001
100 Hz	0.60 to 0.501	0.60 to 0.5001
10 Hz	0.60 to 0.51	0.60 to 0.501

signal (refer to table 1) is applied to the phase/frequency discriminator where it is compared with the difference frequency from the mixer. The phase/frequency discriminator develops a tracking voltage output based on the phase/frequency difference of the high reference signal and the difference frequency from the mixer. The tracking voltage drives the variable vco to the frequency, as determined by the high reference input and the reference voltage supplied by the translator phase-lock loop. The variable vco signal, in the output phase-lock loop, is supplied to a fixed divide-by-10 output circuit, and the output of the divide-by-10 network is supplied to the next decade step.

The variable vco signal, in the output phase-lock loop, is also mixed with the variable vco signal of the translator phase-lock loop, and a difference frequency reference is supplied through a squaring amplifier and applied to the phase/frequency discriminator. When the inputs to the phase/frequency discriminator are the same frequency and in phase, an output lock signal output is supplied.

When lock signals are supplied by both the translator and output phase-lock loops, they are ANDed and supply a decade lock signal output.

#### **2.4.6 Synthesizer Output (Refer to figure 11.)**

Synthesizer output A23 receives units/tens MHz bcd inputs, a fixed 100-kHz reference signal, and a variable high reference signal, and provides a 109.35- to 79.350001-MHz variable injection signal output to the unit under control.

Synthesizer output A23 contains two phase-lock loops. The translator phase-lock loop consists of a phase/frequency discriminator, variable vco, variable divider, voltage/gain control, and a lock detector. The 100-kHz reference signal is applied to the phase/frequency discriminator where it is compared with the 100-kHz signal from the variable divider. The phase/frequency discriminator develops a tracking voltage based on the phase/frequency difference of the 100-kHz signals and the operation of the voltage/gain control circuit caused by the 10- and 20-MHz bcd inputs. The tracking voltage drives the

variable vco to the frequency as determined by the bcd input (programmed division ratio of variable divider). The tracking voltage is also applied as a reference voltage to the voltage/gain control in the output phase-lock loop. The variable vco signal output in the translator phase-lock loop is applied to the mixer in the output phase-lock loop.

The variable vco signal output in the translator phase-lock is also divided (division ratio of the variable divider) and applies as 100-kHz variable reference to the phase/frequency discriminator. When the inputs to the phase/frequency discriminator are the same frequency and in phase, a translator lock signal output is supplied.

The output phase-lock loop consists of a phase/frequency discriminator, variable vco, mixer and squaring amplifier, voltage/gain control, and a lock detector. A high reference signal is applied to the phase/frequency discriminator where it is compared with the difference frequency from the mixer. The phase/frequency discriminator develops a tracking voltage output based on the phase/frequency difference of the high reference signal and the difference frequency from the mixer, and the operation of the voltage/gain control circuit caused by the translator phase-lock loop tracking voltage. The tracking voltage drives the variable vco to the frequency, as determined by the high reference input, and the reference voltage supplied by the translator phase-lock loop is supplied to the unit under control as the variable injection control signal.

The variable vco signal, in the output phase-lock loop, is also mixed with the variable vco signal of the translator phase-lock loop, and the difference frequency reference is supplied through a squaring amplifier and applied to the phase/frequency discriminator. When the inputs to the phase/frequency discriminator are the same frequency and in phase, an output lock signal output is supplied.

When lock signals are supplied by both the translator and output phase-lock loops, they are ANDed and supply a MHz decade lock signal output.

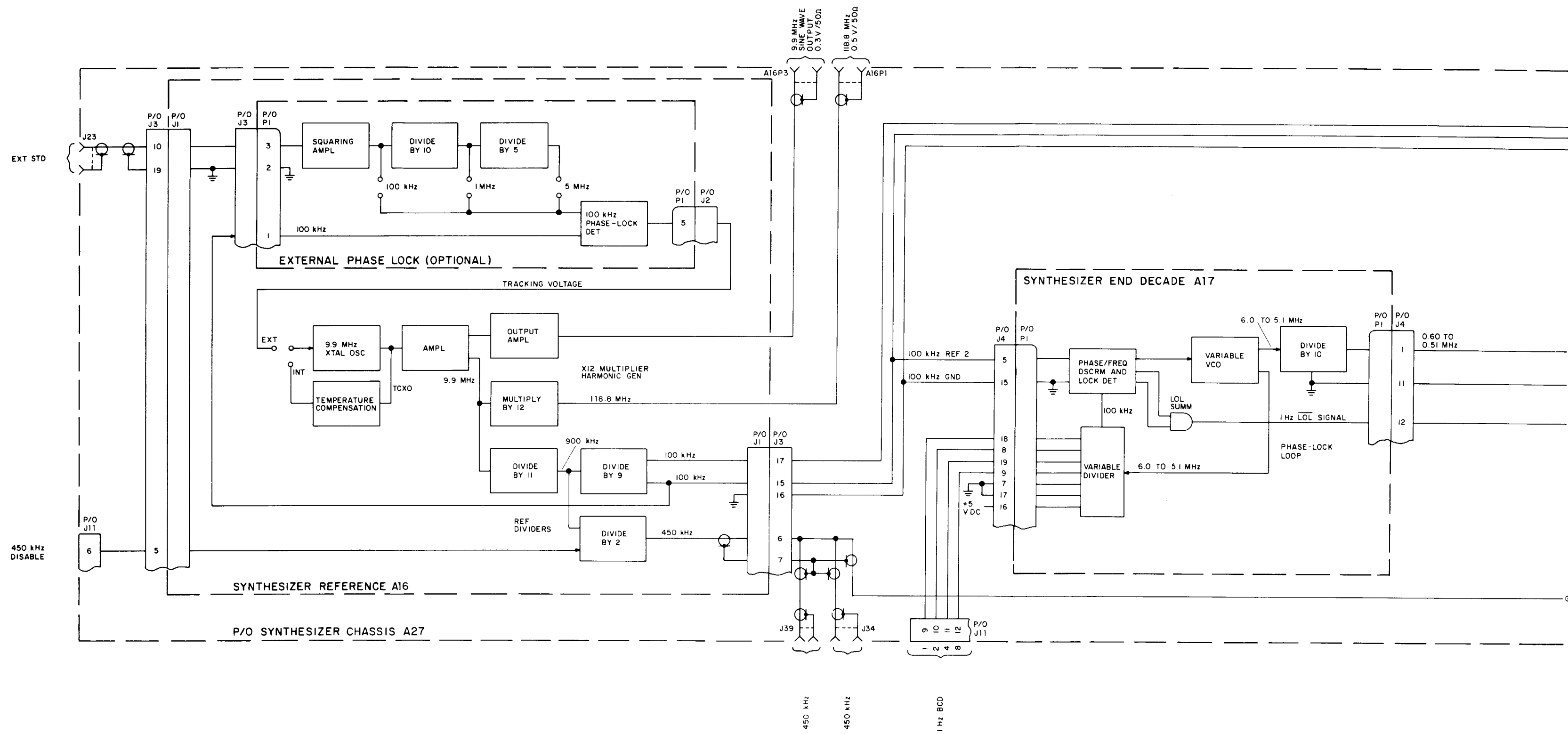

TPA-2572-045

Frequency Synthesizer, Block Diagram  
Figure 11 (Sheet 1 of 4)



P/O SYNTHESIZER CHASSIS A27

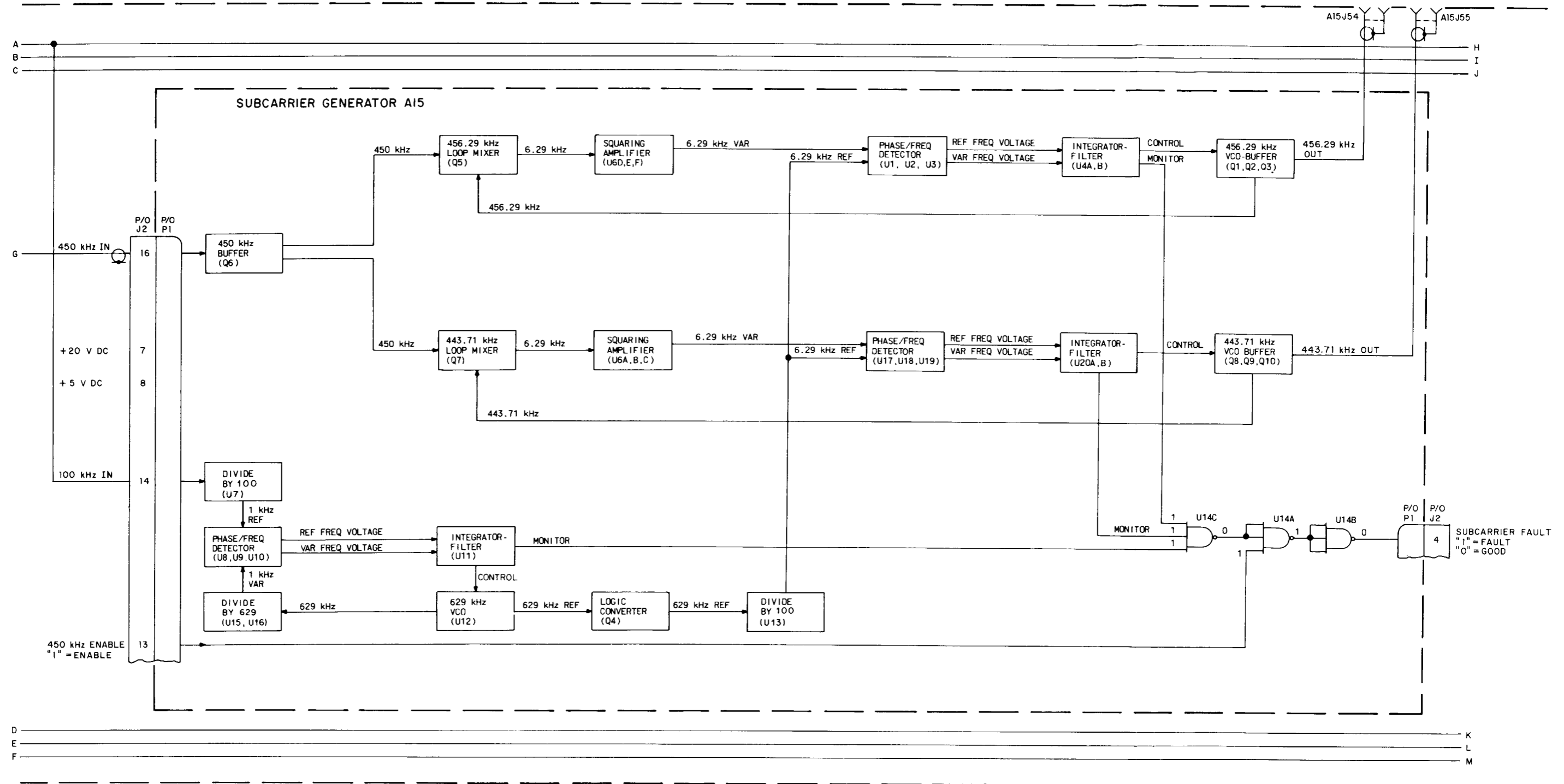

TPA-2572-045

Frequency Synthesizer, Block Diagram Figure 11 (Sheet 2)

P/O SYNTHESIZER CHASSIS A27

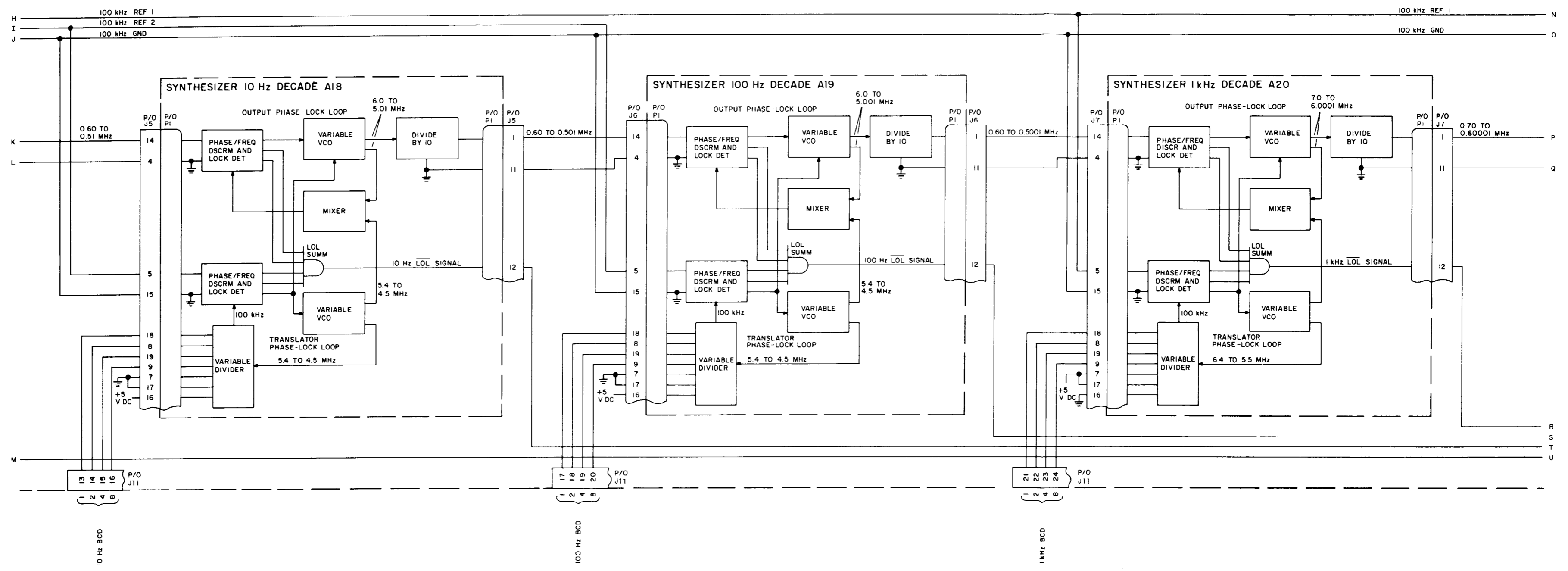

TPA-2572-045

Frequency Synthesizer, Block Diagram  
Figure 11 (Sheet 3)

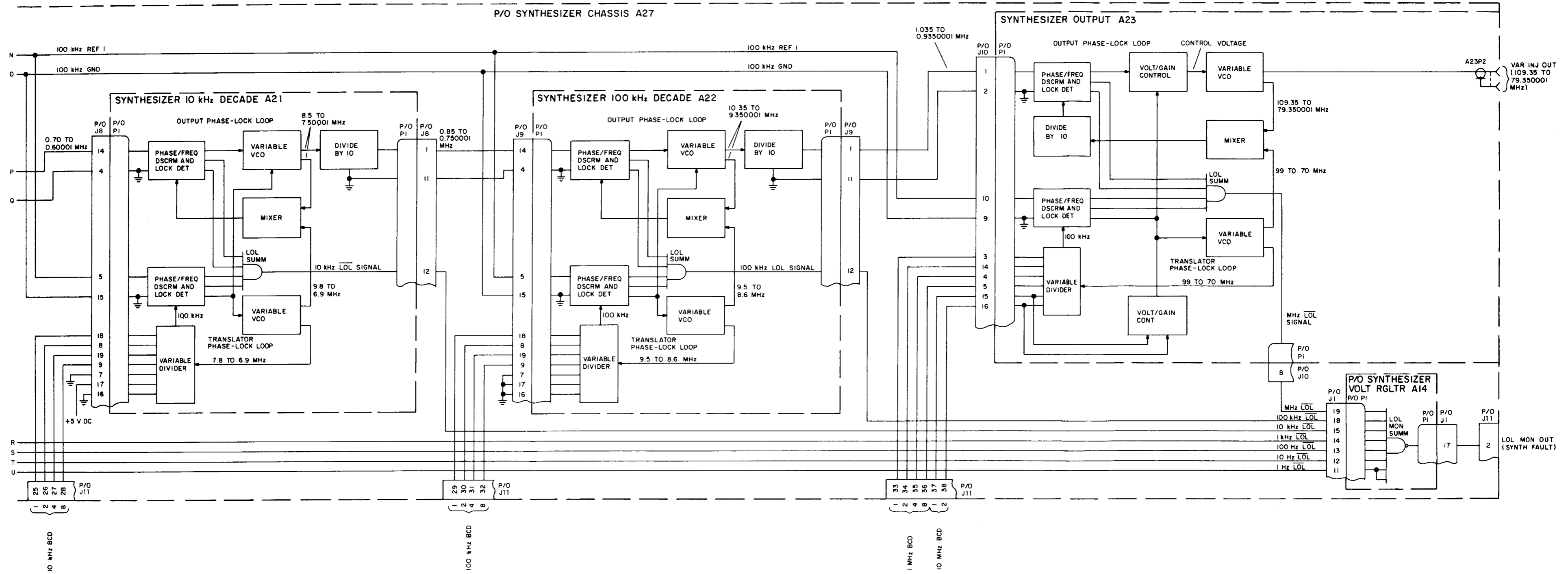

TPA-2572-045

Frequency Synthesizer, Block Diagram  
 Figure 11 (Sheet 4)

## 2.5 Monitor Functions (Refer to figure 12.)

Local monitors in the HF-8014( ) Exciter consist of the lamps on LED status display A2A1 and the meter on the front panel. Monitor information is also contained in the monitor data supplied by the HF-8014A Exciter.

### 2.5.1 Fault and Status Indicators

All indicators are lit by a logic signal to LED status display A2A1. Refer to the LED status display A2A1 instruction section for detailed information on LED status display A2A1. Refer to the operation section, paragraph 4.3, for monitor word format (remote exciter only).

- a. RF OUT (DS1) is lit by a sidetone enable signal at A2J3-9. The logic 1 sidetone enable signal is supplied by control A10. In the HF-8014A Exciter, the sidetone enable signal is also supplied to the parallel input A11 and generates an rf out indication in word 4 of the monitor data. The sidetone enable signal from control A10 is supplied as a logic 0 from the associated power amplifier and inverted by control A10.
- b. PA READY (DS2) is lit by a power amplifier signal at A2J3-10. The logic power amplifier ready signal is supplied by control A10. In the HF-8014A Exciter, the power amplifier ready signal is also supplied to parallel input A11 and generates a power amplifier ready indication in word 4 of the monitor data. The power amplifier ready signal from control A10 is supplied as a logic 0 from the associated power amplifier and inverted by control A10.
- c. PA FAULT (DS3) is lit by a power amplifier fault signal at A2J3-11. The logic 1 power amplifier fault signal is supplied by control A10. In the HF-8014A Exciter, the power amplifier fault signal is also supplied to parallel input A11 and generates a power amplifier fault indication in word 4 of the monitor data. The power amplifier fault signal from control A10 is supplied as a logic 1 from the associated power amplifier and through a driver in control A10.
- d. KEY (DS4) is lit by a key indication signal at A2J3-12. The logic 1 key indication signal is supplied by control A10. In the HF-8014A Exciter, the key indication signal is also supplied to parallel input A11 and generates a key indication in word 4 (system key) of the monitor data. The key indication signal from control A10 is supplied as a logic 0 (key) and is inverted by control A10. Note that the key indication signal, through an internal jumper

on control A10, is supplied as rf transmit signal to channel B2 if A5, channel B1 if A7, channel A2 if A6, channel A1 if A8, and rf translator A9.

- e. EXCITER FAULT (DS5) is lit by an exciter fault signal at A2J3-13. The logic 1 exciter fault signal is supplied by control A10. In the HF-8014A Exciter, the exciter fault signal is also supplied to parallel input A11 and generates a fault indication in word 4 of the monitor data. The exciter fault signal from control A10 is a summary of a power supply fault signal and synthesizer fault signal.

A logic 0 power supply fault signal is supplied by power supply A1. In the HF-8014A Exciter, the power supply fault signal is also supplied to parallel input A11 and generates a fault signal in word 4 of the monitor data. The power supply fault signal from power supply A1 is a summary fault signal resulting from the loss of +8-, +24-, or -15-V dc power supply outputs. The power supply fault is inverted and summed with a synthesizer fault signal and supplied as an exciter fault. When caused by a power supply fault, it is cleared only by changing frequency.

A logic 1 synthesizer fault signal is supplied to voltage regulator A14 in the frequency synthesizer. In the HF-8014A Exciter, the synthesizer fault signal is also supplied to parallel input A11 and generates a fault indication in word 4 of the monitor data. The synthesizer fault signal from the synthesizer subassembly is a summary fault signal resulting from loss of lock on any of the synthesizer decades (1-, 10-, or 100-Hz end decade, 10-Hz decade, 100-Hz decade, 1-kHz decade, 10-kHz decade, 100-kHz decade, and 1-MHz output module). The synthesizer fault signal is summed with a power supply signal and supplied as an exciter fault signal from control A10, as described above.

- f. COUPLER FAULT (DS8) is lit by a coupler fault signal at A2J3-8. The logic 1 coupler fault signal is supplied by control A10. In the HF-8014A Exciter, the coupler fault signal is also supplied to parallel input A11 and generates a coupler fault indication in word 4 of the monitor data. The coupler fault signal from control A10 is supplied as a logic 1 from the associated power amplifier.
- g. AM (DS9) is lit by the AM enable signal at A2J3-4. The logic 1 AM enable signal is supplied from the front panel. In the HF-8014A Exciter, the AM enable signal is also supplied to parallel input A11 and generates an AM indication in word 2 of the monitor data. The AM enable is supplied through the front-panel MODE and CONT switches.

- h. CW (DS10) is lit by the CW enable signal at A2J3-2. The logic 1 CW enable signal is supplied from the front panel. In the HF-8014A Exciter, the CW enable signal is also supplied to parallel input A11 and generates a CW indication in word 2 of the monitor data. The CW enable signal is supplied through the front-panel MODE and CONT switches.
- i. PEAK CLIP (DS11) is lit by the peak clip enable signal at A2J3-1. The logic 1 peak clip enable signal is supplied from the front panel. In the HF-8014A Exciter, the peak clip enable signal is also supplied to parallel input A11 and generates a peak clip indication in word 2 of the monitor data. The peak clip enable signal is supplied through the front panel PEAK CLIP and CONT switches.
- j. PILOT CARR (DS13) is lit by the pilot carrier enable signal at A2J3-3. The logic 1 pilot carrier enable signal is supplied from the front panel. In the HF-8014A Exciter, the pilot carrier enable signal is supplied to parallel input A11 and generates a pilot carrier indication in word 3 of the monitor data. The pilot carrier enable signal is supplied through the front panel PILOT CARR and CONT switches.
- k. ISB (DS14) is lit by the ISB enable signal at A2J3-24. The logic 1 ISB enable signal is supplied from the front panel. In the HF-8014A Exciter, the ISB enable signal is supplied to parallel input A11 and generates an ISB enable indication in word 2 of the monitor data. The ISB enable signal is supplied through the front panel MODE and CONT switches. The ISB enable signal is also supplied to the channel enable switches.
- l. B1 (DS15) is lit by the B1 indicator signal at A2J3-22. The logic 1 B1 indicator signal is supplied from the front panel. In the HF-8014A Exciter, the B1 indicator signal is supplied to parallel input A11 and generates a B1 indicator in word 2 of the monitor data. The B1 indicator signal is supplied through the front-panel CHANNEL ENABLE switch, S5.
- m. A1 (DS16) is lit by the A1 indicator signal at A2J3-21. The logic 1 A1 indicator signal is supplied from the front panel. In the HF-8014A Exciter, the A1 indicator signal is supplied to parallel input A11 and generates an A1 indicator in word 2 of the monitor data. The A1 indicator signal is supplied through the front-panel CHANNEL ENABLE switch, S6.
- n. B2 (DS18) is lit by the B2 indicator signal at A2J3-17. The logic 1 B2 indicator signal is supplied from the front panel. In the HF-8014A Exciter, the B2 indicator is supplied to parallel input A11 and generates a B2 indicator in word 2 of the monitor

- data. The B2 indicator signal is supplied through the front-panel CHANNEL ENABLE switch, S4.
- o. A2 (DS19) is lit by the A2 indicator signal at A2J3-19. The logic 1 A2 indicator signal is supplied from the front panel. In the HF-8014A Exciter, the A1 indicator signal is supplied to parallel input A11 and generates an A2 indicator in word 2 of the monitor data. The A2 indicator signal is supplied through the front-panel CHANNEL ENABLE switch, S7.
- p. PRESEL FAULT (DS23) is lit by a preselector fault signal at A2J3-7. The logic 1 preselector fault signal is supplied by control A10. In the HF-8014A Exciter, the preselector fault signal also is supplied to parallel input A11 and generates a preselector fault indication in word 4 of the monitor data. The preselector fault signal from control A10 is supplied as a logic 1 by the associated preselector and through a driver on control A10.

### 2.5.2 Metering

The front-panel meter is controlled by the METER switch. METER switch A2A2S1 in the HF-8014( ) Exciter has five positions: XMT OUT (+23 FS), CH B2 AF (+3 FS), CH B1 AF (+3 FS), CH A1 AF (+3 FS), and CH A2 AF (+3 FS).

- a. In the XMT OUT (+23 FS) position, a dc signal proportional to the exciter transmit rf output is supplied from rf translator A9 through J7-20, J12-45, P3-45, and METER switch A2A2S1 to meter M1. In the XMT OUT (+23 FS) position, the meter is calibrated to effectively read +23-dB mW full-scale deflection.
- b. In the CH B2 AF (+3 FS) position, a dc signal proportional to the channel B2 transmit line of mic audio input to the channel B2 compression amplifier is supplied from transmit audio A3 (A2-B2) through J1-18, J12-44, P3-44, and METER switch A2A2S1 to meter M1. In the CH B2 AF (+3 FS) position, the meter is calibrated for +3-dB mW full-scale deflection. Compression range in the transmit audio amplifier is -15 to 0 dB mW, indicated by the black segment on the meter.
- c. In the CH B1 AF (+3 FS) position, a dc signal proportional to the channel B1 transmit line of mic audio input to the channel B1 compression amplifier is supplied from transmit audio A4 (A1-B1) through J2-18, J12-43, P3-43, and METER switch A2A2S1 to meter M1. In the CH B1 AF (+3 FS) position, the meter is calibrated for +3-dB mW full-scale deflection. Compression range in the

- transmit audio amplifier is -15 to 0 dB mW, indicated by the black segment on the meter.
- d. In the CH A1 AF (+3 FS) position, a dc signal proportional to the channel A1 transmit line or mic audio input to the channel A1 compression amplifier is supplied from transmit audio A4 (A1-B1) through J2-34, J12-42, P3-42, and METER switch A2A2S1 to meter M1. In the CH A1 AF (+3 FS) position, the meter is calibrated for +3-dB mW full-scale deflection. Compression range in the transmit audio amplifier is -15 to 0 dB mW, indicated by the black segment on the meter.
  - e. In the CH A2 AF (+3 FS) position, a dc signal proportional to the channel A2 transmit line or mic audio input to the channel A2 compression amplifier is supplied from transmit audio A3 (A2-B2) through J1-34, J12-41, P3-41, and METER switch A2A2S1 to meter M1. In the CH A2 AF (+3 FS) position, the meter is calibrated for +3-dB mW full-scale deflection. Compression range in the transmit audio amplifier is -15 to 0 dB mW, indicated by the black segment on the meter.

### **2.6 Power Distribution (Refer to figure 13.)**

Primary power distribution in the HF-80 equipments is controlled by power supply A1. Input power to

power supply A1 is connected to P1 on the exciter rear panel, supplied through F1 (rear panel), S2 (front panel), and S1 (rear panel) to the input power transformer (P/O A1). Power supply A1 uses rectifiers and regulators to produce the following base output voltages: +5, +8, +15, +18, +24, and -15 V dc. These voltages are supplied to cards and modules in the exciter and are the only voltages used except for the following special applications.

In the channel B1, channel B2, channel A1, and channel A2 if's the -15-V dc input is used with a 10-V dc regulator to produce -10-V dc B- for the filter switches.

In control A10, the -15-V dc input is used with a 10-V dc regulator to produce -10.0-V dc reference voltage for TGC.

In parallel output A12, the +15-V dc input is used with a 5.6-V dc regulator to produce +5.6 V dc B+ for output storage registers.

In synthesizer voltage regulator A14, the +24- and +8-V dc inputs are used with series regulators to produce regulated +20- and +5.2-V dc outputs for synthesizer control and B+ voltages.

AD-1.

\* ALL LED'S IN THE STATUS DISPLAY ARE TO BE REVERSED theory 523-0770724

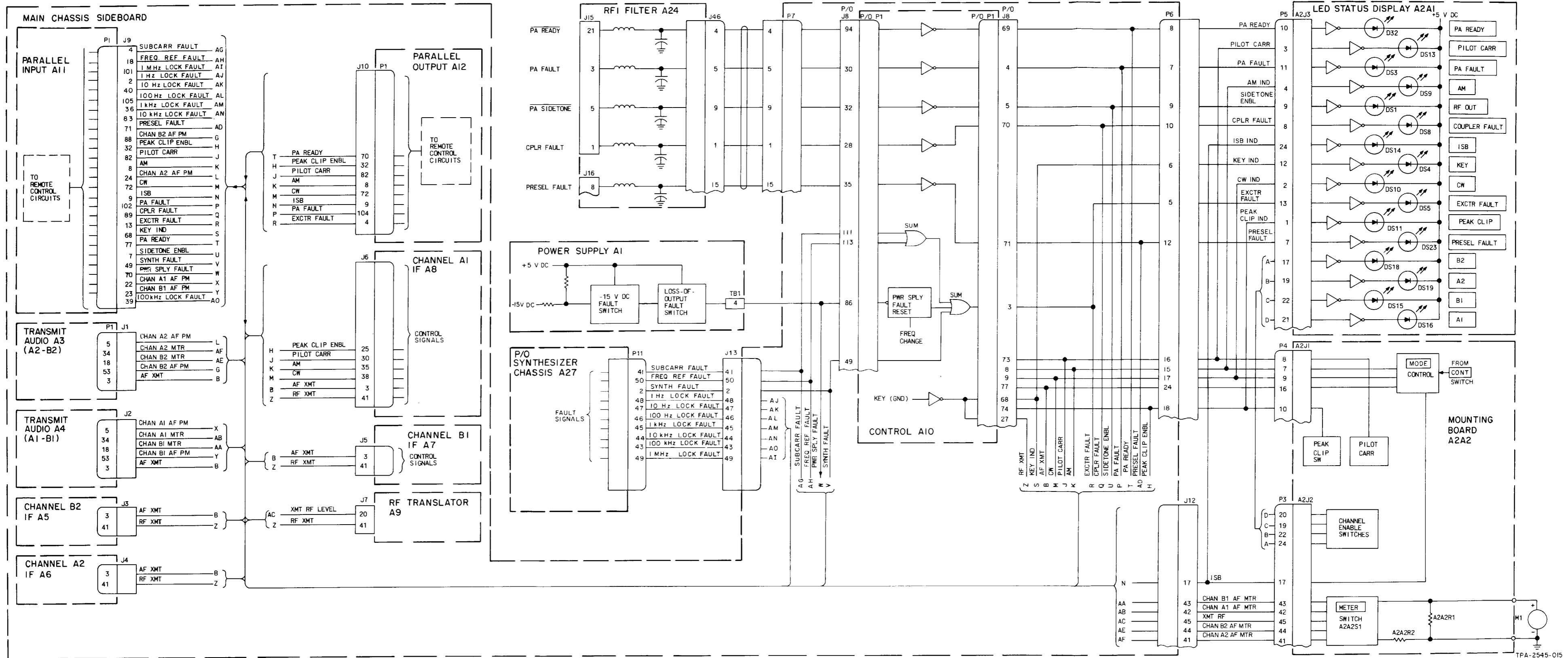

Monitor Functions, Block Diagram Figure 12

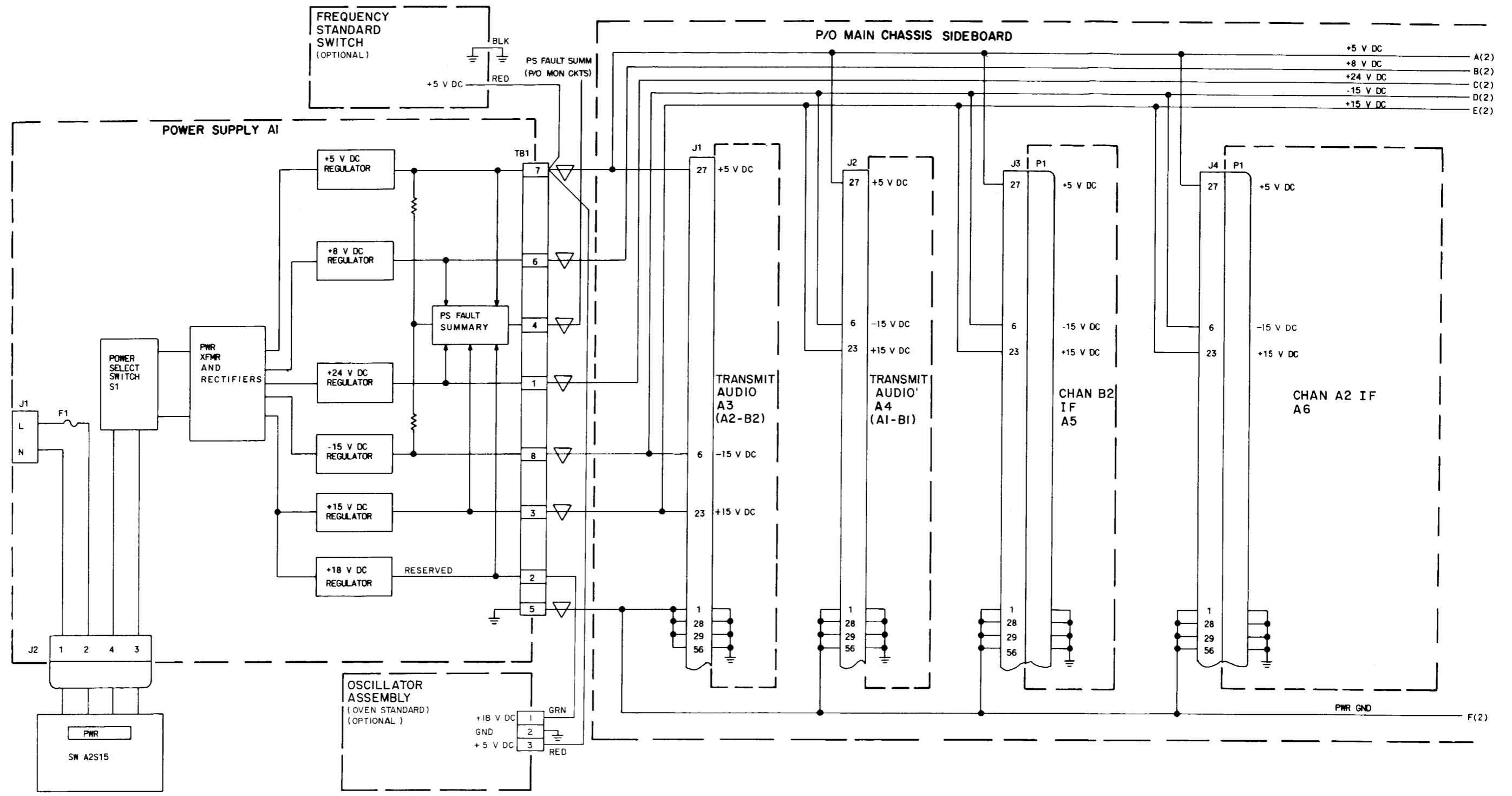

TPA-2565-044

Power Distribution, Block Diagram  
Figure 13 (Sheet 1 of 4)



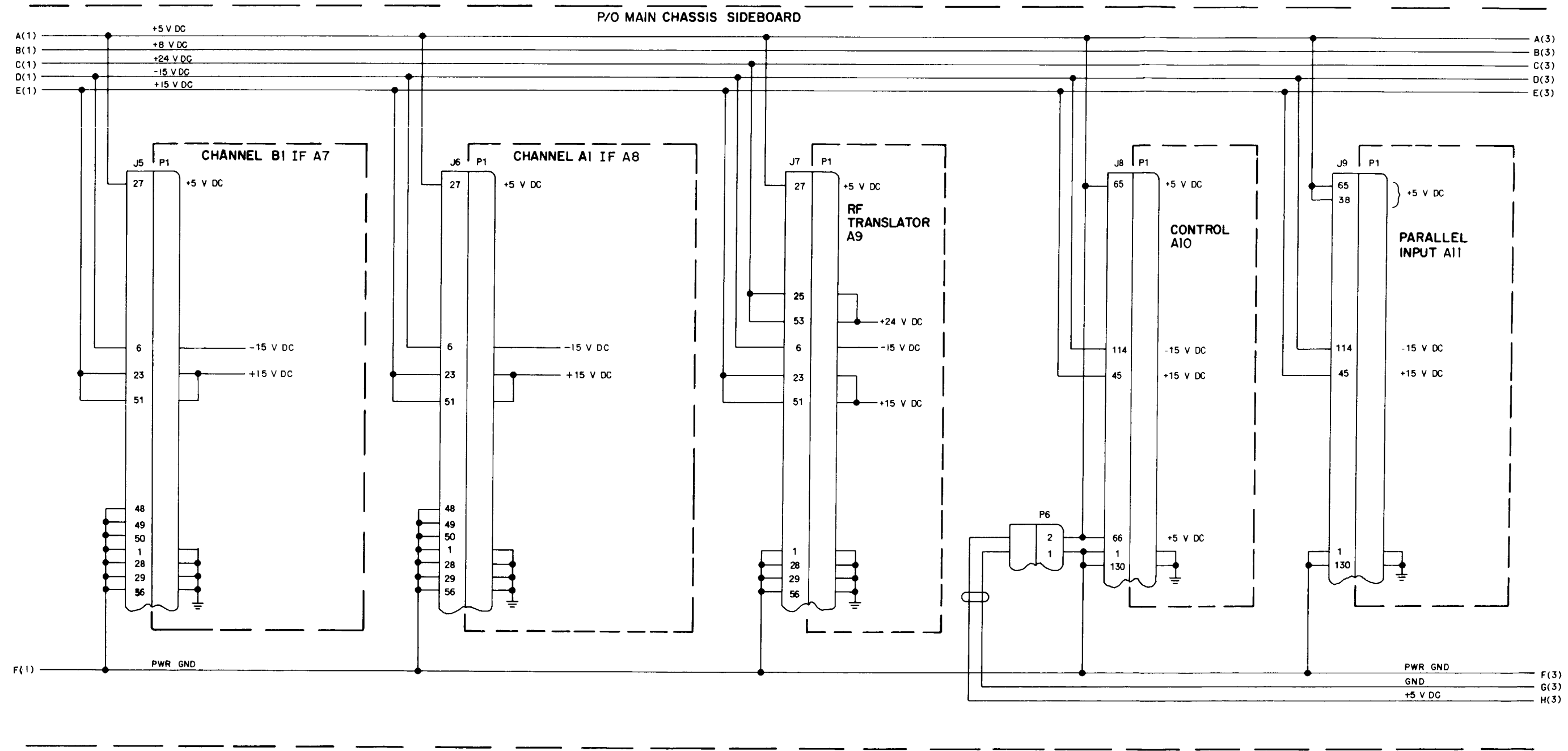

TPA-2565-044

Power Distribution, Block Diagram  
Figure 13 (Sheet 2)

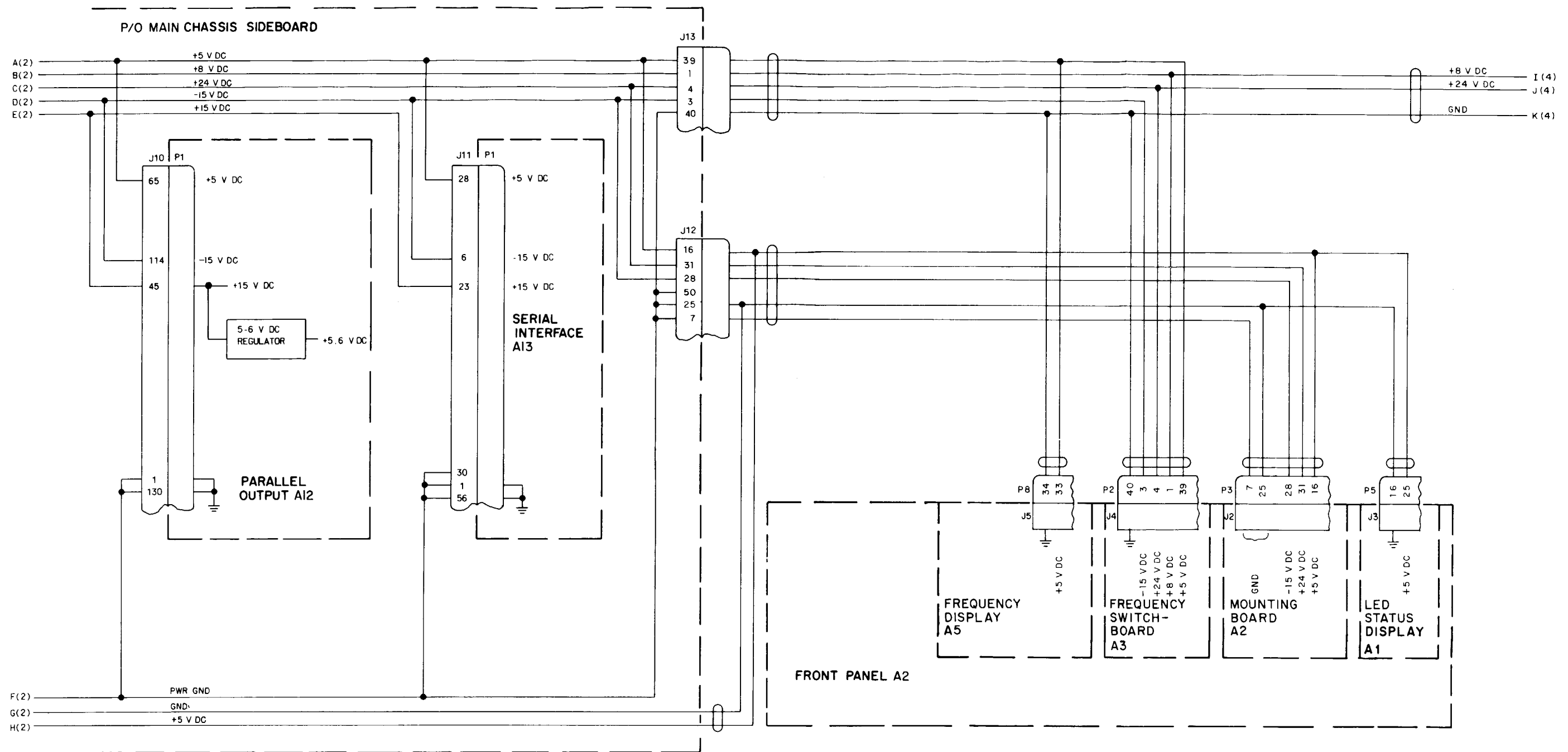

Power Distribution, Block Diagram  
Figure 13 (Sheet 3)

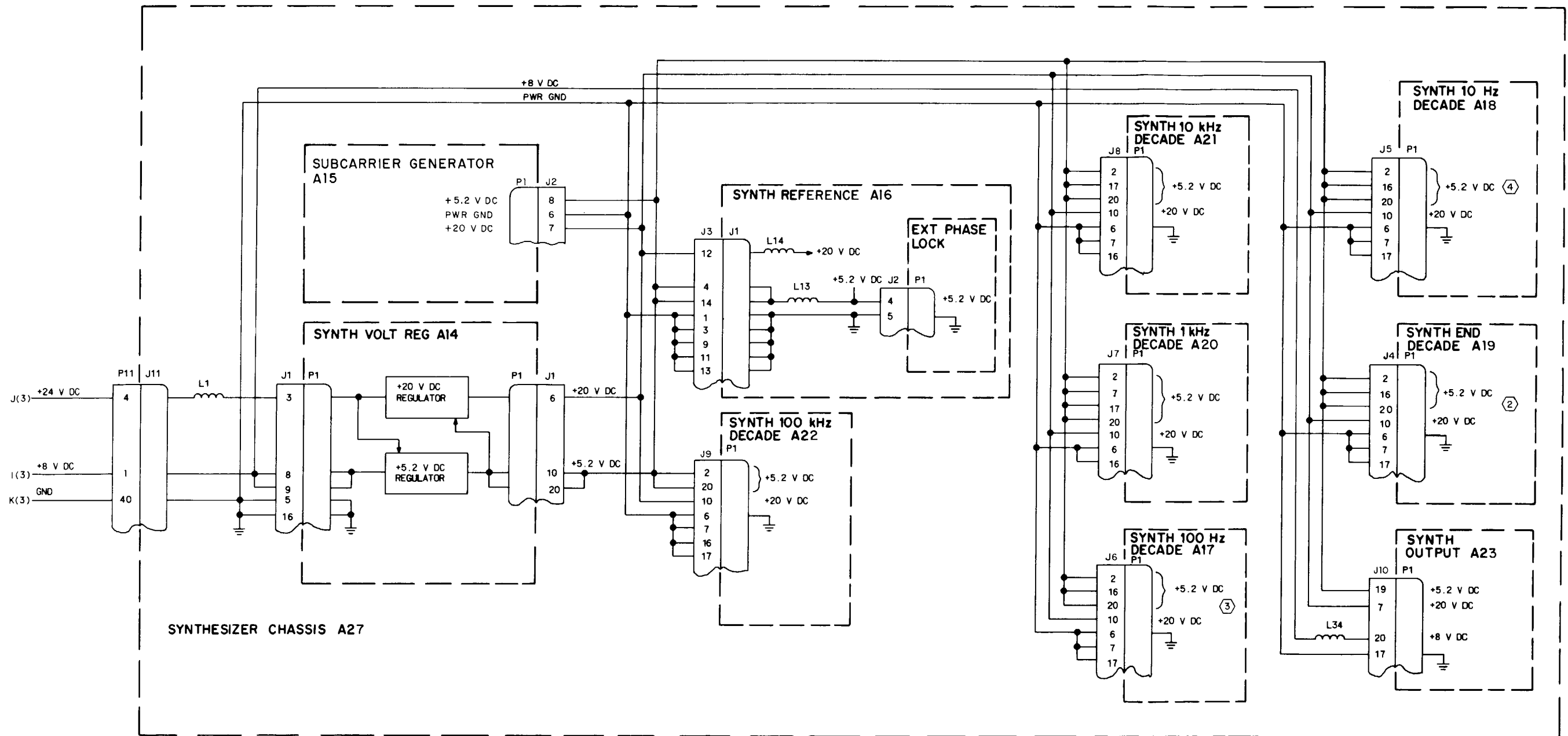

NOTES:

- ① NONSTANDARD SYMBOLS INDICATES HARD WIRED
- ② INDICATES RIBBON CABLE

- ② INSTALLED AS A18 PROVIDES 10 Hz TUNING, AS A19 PROVIDES 100 Hz TUNING, AS A17 PROVIDES 1 Hz TUNING.
- ③ INSTALLED AS A19 FOR 10 Hz TUNING AND 1 Hz TUNING. NOT USED FOR 100 Hz TUNING.

- ④ INSTALLED AS A18 FOR 1 Hz TUNING. NOT USED FOR 10 Hz OR 100 Hz TUNING.

- ⑤ PARTIAL REFERENCE DESIGNATIONS ARE SHOWN; FOR COMPLETE DESIGNATIONS, PREFIX WITH UNIT AND/OR ASSEMBLY DESIGNATION.

Power Distribution, Block Diagram  
Figure 13 (Sheet 4)



**Rockwell  
International**

**maintenance**

# HF-8014( ) Exciter

Collins Telecommunications Products Division

523-0770725-001218

1 January 1981

Printed in USA

## table of contents

<i>Paragraph</i>	<i>Page</i>	<i>Paragraph</i>	<i>Page</i>
<b>1. General</b> .....	1	<b>5. Disassembly/Assembly</b> .....	40
<b>2. Test Equipment and Tools</b> .....	1	5.1 Disassembly .....	40
<b>3. Testing/Troubleshooting</b> .....	1	5.1.1 Meter Lamp Replacement .....	40
3.1 Fault Isolation .....	1	5.1.2 LED Status Display A2A1 Removal .....	40
3.2 Test Point, Voltage, and Signal Levels .....	5	5.1.3 Switch Mounting Board A2A2 Removal .....	40
3.3 Testing/Troubleshooting Procedures .....	5	5.1.4 Frequency Display A2A5 Removal .....	41
<b>4. Alignment/Adjustment</b> .....	36	5.1.5 Frequency Switchboard A2A3 Removal .....	41
4.1 Line Audio Adjustments (Transmit Audio A3 and A4) .....	36	5.2 Assembly .....	41
4.1.1 CHAN A1 XMT LINE ADJ (A4R53) .....	36	5.2.1 Frequency Switchboard A2A3 Installation .....	41
4.1.2 CHAN B1 XMT LINE ADJ (A4R130) .....	36	5.2.2 Frequency Display A2A5 Installation .....	41
4.1.3 CHAN A2 XMT LINE ADJ (A3R53) .....	36	5.2.3 Switch Mounting Board A2A2 Installation .....	42
4.1.4 CHAN B2 XMT LINE ADJ (A3R130) .....	36	5.2.4 LED Status Display A2A1 Installation .....	42
4.2 MIC LVL ADJ (A4R1) (Transmit Audio A4) .....	36	<b>6. Repair</b> .....	42
4.3 Transmit RF Output Level Adjustments (Channel A1 IF A8) .....	37	<b>7. Circuit Card Repair</b> .....	42
4.3.1 Tune Power Adjustment .....	37	7.1 General .....	42
4.3.2 ISB Power Adjustment .....	38	7.2 Replacement of Resistors, Diodes, and Capacitors .....	42
4.3.3 AM Power Adjustment .....	38	7.2.1 Removal .....	42
4.3.4 CW Power Adjustment .....	38	7.2.2 Installation .....	43
4.3.5 Pilot Carrier Adjustment .....	38	7.3 Replacement of Multilead Components (Transistors, Transformers, Dual-in-Line Packages, Relays, Etc) .....	44
4.4 CW Hang Time Adjustment (Control A10) .....	38	7.3.1 Removal .....	44
4.5 Frequency Adjustment (Synthesizer Reference A16) .....	38	7.3.2 Installation .....	44
4.6 Meter Adjustments .....	39	7.4 Electrostatic Discharge Sensitive Devices Precautions .....	45
4.6.1 Transmit Audio Meter Adjustment (Transmit Audio A4) .....	39	7.4.1 Handling of ESDS Devices .....	46
4.6.2 Transmit Audio Meter Adjustments (Transmit Audio A3) .....	39	7.4.2 Storage of ESDS Devices .....	47
4.6.3 Transmit Output Meter Adjustment (RF Translator A9) .....	40	7.4.3 Testing of Subassemblies Containing ESDS Devices .....	47
		7.4.4 Replacement of ESDS Devices .....	47

Maintenance  
HF-8014( ) Exciter

523-0770725-001218



# maintenance

## 1. GENERAL

This section contains information necessary to maintain the HF-8014( ) Exciter. Testing and troubleshooting procedures isolate a fault to a circuit card or chassis-mounted components. Refer to the appropriate circuit card section in this instruction book for fault isolation and repair of components on circuit cards. Figure 1 shows the location of HF-8014( ) Exciter subassemblies.

**Caution**

This equipment contains electrostatic discharge sensitive (ESDS) devices. Special handling methods and materials must be utilized to prevent equipment damage. Refer to paragraph 7.4 Electrostatic Discharge

Sensitive Devices Precautions, before performing maintenance on the equipment.

## 2. TEST EQUIPMENT AND TOOLS

Table 1 lists all test equipment and tools required to test, troubleshoot, align, and repair the HF-8014( ) Exciter.

## 3. TESTING/TROUBLESHOOTING

### 3.1 Fault Isolation

Some failures that may occur in the HF-8014( ) Exciter can be isolated quickly to a faulty card or assembly by using the front panel control and monitor features. Table 2 contains a brief description of indications and isolation of apparent failures.

*Table 1. Test Equipment and Tools.*

ITEM	MINIMUM SPECIFICATIONS	REPRESENTATIVE TYPE
<b>TEST EQUIPMENT</b>		
Vom		Any
Audio voltmeter		Any
Storage oscilloscope		Tektronix 549
Card/module extenders	1-to-1 card/module extenders sufficient to extend card/module above chassis configuration (need 130-pin edge-on extender, 56-pin edge-on extender, rf module extender, synthesizer extender, seven subminiax coax extenders, and a subminiax to BNC coax extender)	Collins TS-8010 (622-3431-001) Includes: One 635-0913-001 One 635-0915-001 One 635-0915-002 Seven 635-9686-001 One 635-9686-002 One 637-2843-001
20-dB pad (2)		Weinschel 50120
Rf signal generator		HP 8640B-001
Dvm		Fluke 8000A
Rf voltmeter		Boonton 92C

Table 1. Test Equipment and Tools (Cont).

ITEM	MINIMUM SPECIFICATIONS	REPRESENTATIVE TYPE
<b>TEST EQUIPMENT</b>		
Counter Dc power supply Variable attenuator Spectrum analyzer Audio oscillator (2) Hybrid transformer Audio generator, 2-tone	0 - 28 V dc, 0 - 5 A 0 to 50 dB mW, 2 to 30-MHz frequency response	Anadex CF735 with option C Any Any HP 141T HP 204C Any Marconi TF-2005R
<b>TOOLS</b>		
Flux Solder Solvent Soldering iron Solder sucker Needle-nose pliers Diagonal cutters Small brush Pipe cleaners	Resin type 0.5 mm (0.020 in) diameter, 63/37 rosin flux core TF/methylene chloride azeotrope 40-watt, 1.5-mm (0.06-in) tip Plunger type with sufficient vacuum to draw molten solder from work area 10.2 cm (4 in) long, with 3-cm (1.125-in) nose 12 cm (4.75 in) long, with 1.3-cm (0.5-in) cutting edge Nylon bristles, 1.3 cm (0.5 in), typical length 12.7 cm (5 in), typical length, industrial quality	Kester 1544 Gardiner type QQS571E SN63 WRMA P-2 Du Pont, Freon TMC Weller model WP-40; with model ST-1 tip Soldavac model SV-026 Utica model 46 Kraeuter model 83 Trumball McFall model Keller-Hull No 1 B. L. Long, industrial pipe cleaners

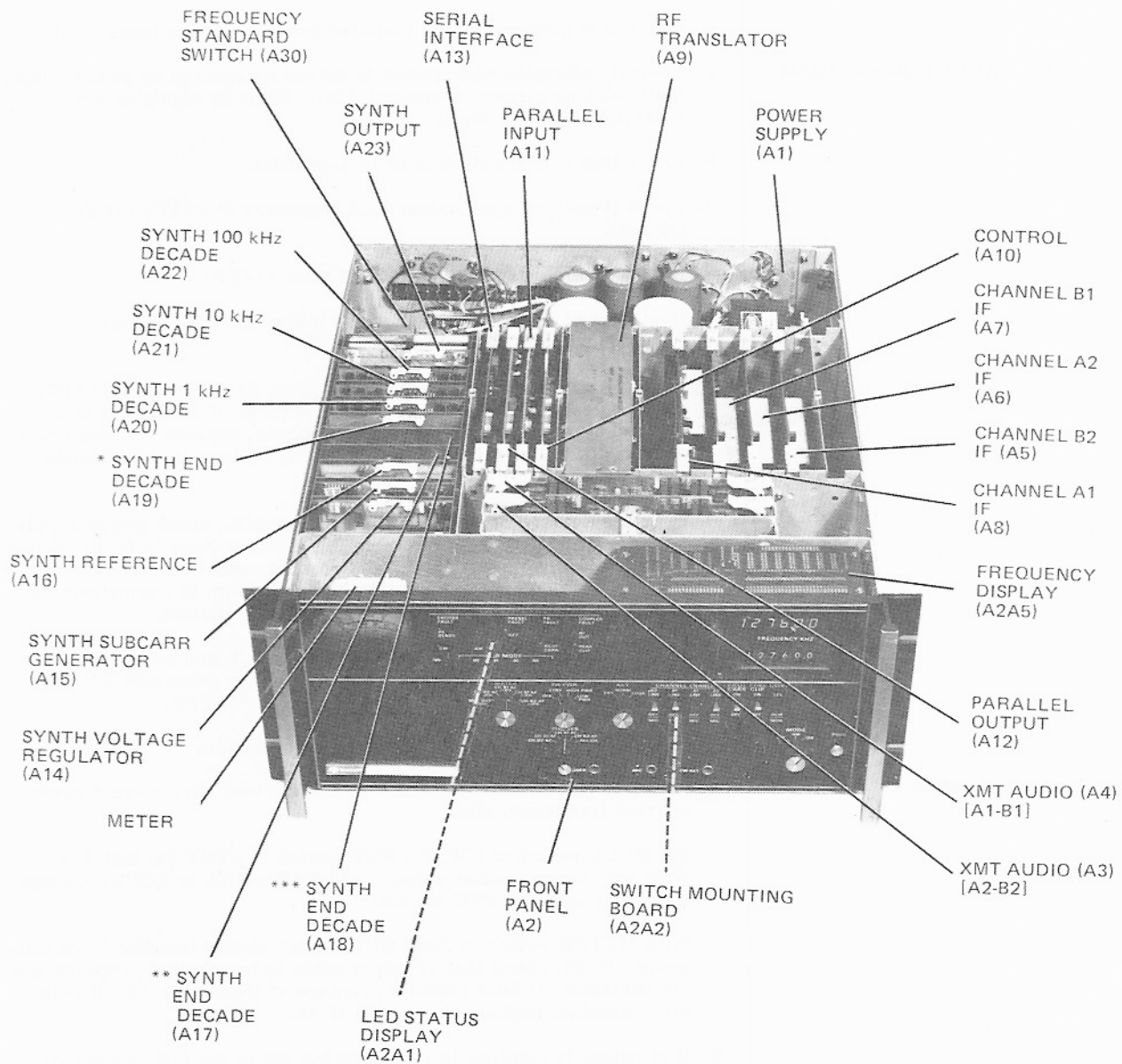

\*100 Hz TUNING  
 \*\*10 Hz TUNING  
 \*\*\*1 Hz TUNING

TPA-2784-017

Subassembly Location  
 Figure 1



Table 2. Fault Isolation.

INDICATION	ISOLATION OF APPARENT FAILURE
<p>Meter lights are dim or fuse fails</p> <p>EXCITER FAULT indicator lights</p> <p>No transmit rf output</p> <p>(Cont)</p>	<p>a. Check that rear panel power selector switches are set to the line voltage being used.</p> <p>b. Check that correct fuse is installed for line voltage being used.</p> <p>a. Normal indication when power is turned on (caused by power supply fault latching circuit on control A10). Clear by changing any FREQUENCY KHZ digit.</p> <p>b. Check that CONT switch is in LCL position.</p> <p>c. Check frequency synthesizer LOL summary at A14TP8 (refer to table 3).</p> <p>If LOL is indicated, check A14TP1 thru A14TP7.</p> <p>If LOL input is not indicated at any test point A14TP1 thru A14TP7, replace control card A10.</p> <p>If LOL input is indicated at any test point A14TP1 thru A14TP7, replace associated decade or output module. If LOL input is not cleared by replacing the associated decade, replace the next lower decade (ie, if 100-kHz LOL is indicated, replace 10-kHz decade, etc).</p> <p>d. If LOL summary at A14TP8 indicates no LOL, check power supply voltages at A1TB1 (refer to table 3). If any voltage is faulty, determine if a short circuit exists in a card by removing one card at a time (refer to power distribution block diagram in theory section of this instruction book as an aid in power isolation).</p> <p>e. If LOL summary at A14TP8 indicates no LOL and power supply checks indicate no fault, check the subcarrier generator LOL at A15TP2 and synthesizer reference LOL at A16TP2.</p> <p>If LOL is indicated, replace appropriate module.</p> <p>a. Check for proper setup (local control, correct key, correct mode, correct frequency, etc).</p> <p>Set MODE switch to CW, PA PWR switch to STBY (so that TGC does not reduce exciter output), and KEY switch to LOCK. Change frequency to reset TGC circuit.</p> <p>With METER switch to XMT OUT, meter should indicate about full-scale. If not, check that rf output cable is terminated properly and not damaged. If fault remains, replace rf translator A9. If fault still remains, replace channel A1 if A8.</p> <p>b. If rf output is obtained in CW mode but not in the ISB channel A1 mode, check that A1 CHANNEL ENABLE switch is in LINE position. Check that audio input signal is within compression range on the front panel meter (METER switch to CH A1 AF (+3FS)). If not, check audio connections. Check audio input level adjustment A4R53. Replace transmit audio A4 (A1-B1).</p> <p>c. If rf output is obtained in ISB channel A1 and channel B1 modes but not in channel A2 or channel B2, replace transmit audio A3 (A2-B2).</p>

Table 2. Fault Isolation (Cont).

INDICATION	ISOLATION OF APPARENT FAILURE
	<p>d. If rf output is obtained in ISB channel A1 mode but not in one of the other ISB channels (A2, B1, B2) replace the applicable if card(s) (A5, A6, A7).</p>

**3.2 Test Point, Voltage, and Signal Levels**

As an additional aid in testing and troubleshooting, voltage and signal levels that are easily accessible are given in table 3. These levels, when used with tables 2, 4, and 5, further enable the user to isolate and identify faults.

**Note**

To check signal levels on power supply A1, the bottom dust cover must be removed from the exciter. To check all other signal levels, the top dust cover must be removed from the exciter. In addition, to check synthesizer signal levels on cards A14 through A23, the synthesizer top cover must be removed.

**Caution**

This equipment contains electrostatic discharge sensitive (ESDS) devices. Special handling methods and materials must be utilized to prevent equipment damage. Refer to paragraph 7.4 Electrostatic Discharge Sensitive Devices Precautions, before performing maintenance on this equipment.

Test procedures in tables 4 and 5 are presented in a manner that allows complete testing or testing of specific characteristics only. After completion of setup (test 1), test procedures may be entered at any numbered test.

**3.3 Testing/Troubleshooting Procedures**

Testing/troubleshooting procedures isolate a fault to a circuit card or chassis-mounted component. A test setup diagram is shown in figure 2. Testing/troubleshooting procedures are presented in tabular format. Table 4 presents a minimum performance test procedure that permits a quick check of the performance of the receiver using a minimum amount of test equipment. Table 5 presents a detailed performance test procedure that permits complete repair of the unit and returns the unit to satisfactory operation.

**Note**

Unless otherwise specified in testing, all rf signal inputs are open-circuit inputs (in series with 6-dB pad), rf signals are not modulated, rf outputs are loaded with 50 ohms, and audio outputs are loaded with 600 ohms.

Meter level readings in testing apply with factory level settings. Readings may not be valid if field level adjustments have been made.

Table 3. Test Point, Voltage, and Signal Levels.

CARD/MODULE	TEST POINT	FUNCTION	SIGNAL, DESCRIPTION
Power supply A1	TB1-1	+24 V dc	+24 V dc.
	TB1-2	+18 V dc	+18 V dc.
	TB1-3	+15 V dc	+15 V dc.
	TB1-4	Power supply fault	Fault $\cong$ +5 V dc (indicates low voltage in +24-, +18-, +15-, +8-, or -15-V dc supplies), no fault $\cong$ 0 V dc.
	TB1-5	Ground	0 V dc (signal common).
	TB1-6	+8 V dc	+8 V dc.
	TB1-7	+5 V dc	+5 V dc.
	TB1-8	-15 V dc	-15 V dc.
Transmit audio A3 (A2-B2)	TP1	Ground	0 V dc (signal common).
	TP2	Channel A2 transmit line	35 to 200 mV in compression range (200 mV $\cong$ top of compression range on front panel meter with METER switch in CH A2 AF (+3FS) position).
	TP3	Channel A2 transmit af	30 mV nominal across compression range.
	TP4	Not used	
	TP5	Channel B2 transmit af	30 mV nominal across compression range.
	TP6	Channel B2 transmit line	35 to 200 mV in compression range (200 mV $\cong$ top of compression range on front panel meter with METER switch in CH B2 AF (+3FS) position).
Transmit audio A4 (A1-B1)	TP1	Ground	0 V dc (signal common).
	TP2	Channel A1 transmit line	35 to 200 mV in compression range (200 mV $\cong$ top of compression range on front panel meter with METER switch in CH A1 AF (+3FS) position).
	TP3	Channel A1 transmit af	30 mV nominal across compression range.
	TP4	Mic af	15 to 850 mV in compression range.
	TP5	Channel B1 transmit af	30 mV nominal across compression range.
	TP6	Channel B1 transmit line	35 to 200 mV in compression range (200 mV $\cong$ top of compression range on front panel meter with METER switch in CH B1 AF (+3FS) position).
Channel B2 if A5	TP1	Ground	0 V dc (signal common).
	TB2	Channel B2 enable	Enable $\cong$ 0 V dc; disable $\cong$ -10 V dc.

Table 3. Test Point, Voltage, and Signal Levels (Cont).

CARD/MODULE	TEST POINT	FUNCTION	SIGNAL, DESCRIPTION
Channel A2 if A6	TP1	Ground	0 V dc (signal common).
	TP2	Channel A2 enable	Enable $\cong$ 0 V dc; disable $\cong$ -10 V dc.
Channel B1 if A7	TP1	Ground	0 V dc (signal common).
	TP2	Channel B1 enable	Enable $\cong$ 0 V dc; disable $\cong$ -10 V dc.
Channel A1 if A8	TP1	Ground	0 V dc (signal common).
	TP2	CW enable	Enable $\cong$ 0 V dc; disable $\cong$ -9.5 V dc.
	TP3	Channel A1 enable	Enable $\cong$ 0 V dc; disable $\cong$ -9.5 V dc.
Control A10	TP1	Ground	0 V dc (signal common).
	TP2	System key	Key $\cong$ 0 V dc; unkey $\cong$ +5 V dc.
	TP3	Exciter tune	Tune $\cong$ 0 V dc (pa tune cycle only); normal $\cong$ +5 V dc.
	TP4	ALC input	Range = 0 to -5.0 V dc.
	TP5	Clock	5-V p-p clock signal (1000 to 1800 Hz) during pa tune cycle only.
			<div style="border: 1px solid black; display: inline-block; padding: 2px;">Note</div>
			TGC input active only during exciter tune.
	TP6	TGC input	TGC input more negative than -5.25 V dc reduces exciter output; TGC input more positive than -4.75 V dc increases exciter output; TGC input between -4.75 and -5.25 V dc holds exciter output.
	TP7	TGC threshold	-5.25 $\pm$ 0.05 V dc.
	TP8	ALC output	Range = 0 to +9.0 V dc.
	TP9	Pa ready	Ready $\cong$ 0 V dc; not ready $\cong$ +5 V dc.
	TP10	Tune start	Pulse (50 ms min, 150 ms typical) enable $\cong$ 0-V dc pulse. (See note 3.)
	TP11	Pa sidetone enable	Enable $\cong$ 0 V dc; disable $\cong$ +5 V dc.
	TP12	TGC out	Range = 0 to +3.2 V dc (min to max attenuation).
TP13	Pa low-voltage enable	Enable $\cong$ 0 V dc. (See note 3.)	
TP14	Pa high-voltage enable	Enable $\cong$ 0 V dc. (See note 3.)	

Table 3. Test Point, Voltage, and Signal Levels (Cont).

CARD/MODULE	TEST POINT	FUNCTION	SIGNAL, DESCRIPTION
Parallel input A11	TP1	Ground	0 V dc (signal common).
	TP2	WD4G (output)	} Word initiate strobes (gates); initiate $\cong$ +5 V dc, initiate $\cong$ 0 V dc.
	TP3	WD3G (output)	
	TP4	WD1G (output)	
	TP5	WD2G (output)	
Parallel output A12	TP1	Ground	0 V dc (signal common).
	TP2	Data (input)	Serial data from serial interface card (0- or +5-V dc logic levels).
	TP3	Clock (input)	Gated data clock from serial interface A13 (0- or +5-V dc logic levels).
	TP4	Word 4 load strobe	Load pulse ( $\cong$ +5 V dc) generated on reception of word 4 data.
	TP5	Remote rf gain control (output)	Analog dc level (0 to -5.0 V dc), depending on remote RF GAIN setting (MAX $\cong$ 0 V dc). In local operation $\cong$ 0 V dc.
	TP6	Word 2 load strobe	Load pulse ( $\cong$ +5 V dc) generated on reception of word 2 data.
	TP7	ADRG (output)	Address gate pulse ( $\cong$ +5 V dc) generated by a change in address.
	TP8	Remote frequency change (output)	Load pulse ( $\cong$ +5 V dc) generated on reception of word 1 data.
	TP9	Word 3 load strobe	Load pulse ( $\cong$ +5 V dc) generated on reception of word 3 data.
Serial interface A13	TP1	Ground	0 V dc (signal common).
	TP2	Strobe (output)	Strobe pulse ( $\cong$ +5 V dc) to parallel output A12.
	TP3	Clock (output)	Gated data clock (0- or +5-V dc logic levels) to parallel output A12.
	TP4	Data (output)	Serial data (0- or +5-V dc logic levels) to parallel output A12.
	TP5	Serial data (input)	Received serial line data (0- or +5-V dc logic levels). RS-232C or FSK detected data signals.
	TP6	Serial data (output)	Transmitted serial line data (0- or +5-V dc logic levels). Data signals prior to level setting or FSK modulation.
	TP7	Microprocessor clock output	921.6 kHz clock output (0- or +5-V dc logic levels) to frequency divider.
(Cont)			

Table 3. Test Point, Voltage, and Signal Levels (Cont).

CARD/MODULE	TEST POINT	FUNCTION	SIGNAL, DESCRIPTION
Serial interface A13 (Cont)	TP8	Halt input	Ground (0 V dc) applied to this input halts microprocessor program. Normal (+5 V dc) enables microprocessor.
	TP9	Reset input	Power supply interrupt reset ( $\cong +5$ V dc, $\overline{\text{reset}} \cong 0$ V dc) to microprocessor.
Synthesizer voltage regulator A14	TP1	1-Hz $\overline{\text{LOL}}$ (input)	Loss of lock $\cong 0$ V dc, $\overline{\text{loss of lock}} +5$ V dc. Signal received from associated decade card (including output module).
	TP2	10-Hz $\overline{\text{LOL}}$ (input)	
	TP3	100-Hz $\overline{\text{LOL}}$ (input)	
	TP4	1-kHz $\overline{\text{LOL}}$ (input)	
	TP5	10-kHz $\overline{\text{LOL}}$ (input)	
	TP6	100-kHz $\overline{\text{LOL}}$ (input)	
	TP7	MHz $\overline{\text{LOL}}$ (input)	
	TP8	LOL summary (freq synt fault)	Fault $\cong +5$ V dc; $\overline{\text{fault}} \cong 0$ V dc. Supplied to control A10.
	TP9	+5.2 V dc reg (output)	+5.2 V dc.
	TP10	+24 V dc (input)	+24 V dc.
	TP11	+8 V dc (input)	+8 V dc.
	TP12	+20 V dc reg (output)	+20 V dc.
	TP13	Ground	0 V dc (signal common).
Synthesizer subcarrier generator A15	TP1	Ground	0 V dc (signal common).
	TP2	Subcarrier fault  <div style="border: 1px solid black; padding: 2px; display: inline-block; margin: 5px 0;">Note</div> Refer to end of table 3 for fixed injection levels of subcarrier outputs.	Fault $\cong +5$ V dc; $\overline{\text{fault}} \cong 0$ V dc. Fault caused by loss of lock in synthesizer subcarrier generator, A15, loss of 456.29-kHz injection, or loss of 443.71-kHz injection. Subcarrier fault circuit disabled when 450-kHz enable signal is removed.
Synthesizer reference A16  (Cont)	TP1	Ground	0 V dc (signal common).
	TP2	Frequency reference fault	Fault $\cong +5$ V dc; $\overline{\text{fault}} \cong 0$ V dc. Fault caused by loss of 9.9-MHz injection, loss of 118-MHz injection, or (when 450-kHz enable is applied) the loss of the 450-kHz injection. 450-kHz injection fault circuit is disabled when 450-kHz enable signal is removed.

Table 3. Test Point, Voltage, and Signal Levels (Cont).

CARD/MODULE	TEST POINT	FUNCTION	SIGNAL, DESCRIPTION
<div style="border: 1px solid black; display: inline-block; padding: 2px;">Note</div> <p>The following are fixed injection levels that are accessible by extending synthesizer subcarrier generator A15, A16 and synthesizer output module A23. All levels are measured out-of-circuit with a 50-ohm load into an rf voltmeter except as noted.</p>			
Synthesizer subcarrier generator A15	J1-20	456.29-kHz injection	456.29 kHz, 0.3 V rms (measured in circuit with a high impedance load into an rf voltmeter). Supplied to channel A2 if A6 (A6J5).
	J1-1	443.71-kHz injection	443.71 kHz, 0.3 V rms (measured in circuit with a high impedance load into an rf voltmeter). Supplied to channel B2 if A5 (A5J5).
Synthesizer reference A16	J1-6	450-kHz injection	450 kHz, 0.3 V rms (measured in circuit with a high impedance load into an rf voltmeter). Supplied to channel A1 if A8 (A8J5) and channel B1 if A7 (A7J5).
	P1	118.8-MHz injection	118.8 MHz, 0.5 V rms. Supplied to rf translator A9 (A9J6).
	P3	9.9-MHz injection	9.9 MHz, 0.3 V rms. Supplied to channel A1 if A8 (A8J3).
Synthesizer output A22	P2	109.35- to 79.35-MHz variable injection	109.35 to 79.35 MHz, 0.5 V rms. Front panel FREQUENCY kHz of 00 000.00 $\cong$ 109.350 00 MHz, 29 999.99 $\cong$ 79.350 01 MHz. Supplied to rf translator A9 (A9J5).
<div style="border: 1px solid black; display: inline-block; padding: 2px;">Note</div> <ol style="list-style-type: none"> <li>1. All signal levels are rms unless otherwise noted.</li> <li>2. Nominal voltage levels only are given unless otherwise noted.</li> <li>3. Enable <math>\cong</math> 0 V dc; disable <math>\cong</math> the pullup voltage in the pa when the pa control cable is connected (pa control cable not connected presents an open circuit only).</li> </ol>			





Table 4. HF-8014( ) Exciter, Minimum Performance Test Procedure.

PROCEDURE	NORMAL INDICATION	IF INDICATION IS ABNORMAL																				
<p>a. Set front panel controls as follows:</p> <table data-bbox="239 510 690 963"> <tr><td>PWR</td><td>Off</td></tr> <tr><td>METER</td><td>XMT OUT</td></tr> <tr><td>PA PWR</td><td>OFF</td></tr> <tr><td>KEY</td><td>EXT</td></tr> <tr><td>PEAK CLIP</td><td>OFF</td></tr> <tr><td>PILOT CARR</td><td>OFF</td></tr> <tr><td>MODE</td><td>CW</td></tr> <tr><td>CHANNEL ENABLE</td><td>A1 OFF B1 OFF B2 OFF A2 OFF</td></tr> <tr><td>CONT</td><td>LCL</td></tr> <tr><td>FREQUENCY</td><td>18 888.8 kHz</td></tr> </table> <p>b. Verify that power select switches are set to agree with available power-line voltage. Remove top cover from unit.</p> <p>c. Plug in line cord. Connect rf voltmeter through 50-ohm load to XMT OUT jack J22 on rear panel.</p> <p>d. Press PWR switch one time to on position.</p> <p>e. Change frequency to 1888.7 kHz.</p> <p>f. Set KEY to LOCK.</p> <p>g. Plug phones into phone jack. Set PHONE switch to ALL CH.</p> <p>h. Connect a jumper between ground and A10TP3.</p> <p>i. Remove jumper between ground and A10TP3.</p>	PWR	Off	METER	XMT OUT	PA PWR	OFF	KEY	EXT	PEAK CLIP	OFF	PILOT CARR	OFF	MODE	CW	CHANNEL ENABLE	A1 OFF B1 OFF B2 OFF A2 OFF	CONT	LCL	FREQUENCY	18 888.8 kHz	<p>Pilot lamps in meter light.</p> <p>EXCITER FAULT indicator lights.</p> <p>EXCITER FAULT indicator goes out.</p> <p>Frequency display indicates 1888.7 kHz.</p> <p>KEY indicator is lit.</p> <p>Exciter meter indicates off scale.</p> <p>Rf voltmeter indicates more than +20 dB mW.</p> <p>Tone is present in phones.</p> <p>Rf voltmeter indicates +20.5 to +22.5 dB mW.</p> <p>Rf voltmeter indication is same as step f.</p>	<p>Check power supply A1.</p> <p>Check control A10.</p> <p>Check control A10 and power supply A1.</p> <p>Check frequency display A2A5.</p> <p>Check control A10 and LED status display A2A1.</p> <p>Check rf translator A9.</p> <p>Check rf translator A9.</p> <p>Check transmit audio A4 (A1-B1).</p> <p>Check channel A1 if A8.</p> <p>Check control A10.</p>
PWR	Off																					
METER	XMT OUT																					
PA PWR	OFF																					
KEY	EXT																					
PEAK CLIP	OFF																					
PILOT CARR	OFF																					
MODE	CW																					
CHANNEL ENABLE	A1 OFF B1 OFF B2 OFF A2 OFF																					
CONT	LCL																					
FREQUENCY	18 888.8 kHz																					

Table 4. HF-8014( ) Exciter, Minimum Performance Test Procedure (Cont).

PROCEDURE	NORMAL INDICATION	IF INDICATION IS ABNORMAL
<p>j. Set METER switch to CH A1 AF (+3FS).</p> <p>k. Connect microphone to MIC jack.</p> <p>l. Set CHANNEL ENABLE A1 to MIC and MODE to AM.</p> <p>m. Set KEY to NORM.</p> <p>n. Press microphone ptt switch and talk into microphone.</p> <p>o. Set MODE to ISB, CHANNEL ENABLE A2 to MIC, A1 to OFF, and METER switch to CH A2 AF (+3FS).</p> <p>p. Press microphone ptt switch and talk into microphone.</p> <p>q. Repeat steps o thru p for channels B1 and B2.</p> <p>r. Return exciter to operational status.</p>	<p>Exciter meter indicates compression (black segment).</p> <p>Rf voltmeter indicates rf output with amplitude variations as voice input changes.</p> <p>Exciter meter indicates compression (black segment).</p> <p>Rf voltmeter indicates rf output with amplitude variations as voice input changes.</p> <p>Same as step p.</p>	<p>Check transmit audio A4 (A1-B1).</p> <p>Check channel A1 if A8 and rf translator A9.</p> <p>Check transmit audio A3 (A2-B2).</p> <p>Check channel A2 if A6.</p> <p>Check channel B2 if A5 or channel B1 if A7, as applicable.</p>

Table 5. HF-8014( ) Exciter Detailed Performance Test Procedures.

TEST	PROCEDURE	NORMAL INDICATION	IF INDICATION IS ABNORMAL																								
<p>1. Power supply voltages</p> <p>(Cont)</p>	<p>a. Unplug line cord. Remove top and bottom covers.</p> <p>b. Verify that power select switches are set to agree with available power-line voltage.</p> <p>c. Set front panel controls as follows:</p> <table border="0" style="width: 100%;"> <tr> <td style="width: 60%;">PWR</td> <td>Off</td> </tr> <tr> <td>METER</td> <td>XMT OUT</td> </tr> <tr> <td>PA PWR</td> <td>OFF</td> </tr> <tr> <td>KEY</td> <td>EXT</td> </tr> <tr> <td>PEAK CLIP</td> <td>OFF</td> </tr> <tr> <td>PILOT CARR</td> <td>OFF</td> </tr> <tr> <td>MODE</td> <td>CW</td> </tr> <tr> <td>CHANNEL ENABLE</td> <td>A1 OFF</td> </tr> <tr> <td></td> <td>B1 OFF</td> </tr> <tr> <td></td> <td>B2 OFF</td> </tr> <tr> <td></td> <td>A2 OFF</td> </tr> <tr> <td>CONT</td> <td>LCL</td> </tr> </table> <p>d. Plug in line cord.</p> <p>e. Press PWR switch one time to on position. Set FREQUENCY to 8000.0 kHz.</p> <div style="border: 1px solid black; padding: 2px; width: fit-content; margin: 10px auto;"> <p><i>Caution</i></p> </div> <p>Dangerous voltages are present on terminals on the bottom of the exciter.</p> <p>f. Connect a digital multimeter (dmm) between A1TB1-7 and A1TB1-5 (ground).</p> <p>g. Connect dmm between A1TB1-6 and A1TB1-5.</p> <p>h. Connect dmm between A1TB1-1 and A1TB1-5.</p> <p>i. Connect dmm between A1TB1-3 and A1TB1-5.</p> <p>j. Connect dmm between A1TB1-8 and A1TB1-5.</p> <p>k. Turn exciter power off.</p>	PWR	Off	METER	XMT OUT	PA PWR	OFF	KEY	EXT	PEAK CLIP	OFF	PILOT CARR	OFF	MODE	CW	CHANNEL ENABLE	A1 OFF		B1 OFF		B2 OFF		A2 OFF	CONT	LCL	<p>Pilot lamps in meter light.</p> <p>Dmm indicates +4.80 to +5.20 V dc.</p> <p>Dmm indicates +7.60 to +8.40 V dc.</p> <p>Dmm indicates +23.0 to +25.0 V dc.</p> <p>Dmm indicates +14.4 to +15.6 V dc.</p> <p>Dmm indicates -14.6 to -15.4 V dc.</p>	<p>Check power supply A1.</p> <p>Repair or replace power supply A1.</p> <p>Same as step c.</p> <p>Same as step c.</p> <p>Same as step c.</p> <p>Same as step c.</p>
PWR	Off																										
METER	XMT OUT																										
PA PWR	OFF																										
KEY	EXT																										
PEAK CLIP	OFF																										
PILOT CARR	OFF																										
MODE	CW																										
CHANNEL ENABLE	A1 OFF																										
	B1 OFF																										
	B2 OFF																										
	A2 OFF																										
CONT	LCL																										

Table 5. HF-8014( ) Exciter Detailed Performance Test Procedures (Cont).

TEST	PROCEDURE	NORMAL INDICATION	IF INDICATION IS ABNORMAL																								
<p>2. Controls and indicators</p> <p>(Cont)</p>	<p>a. Set front panel controls as follows:</p> <table border="0"> <tr> <td>PWR</td> <td>Off</td> </tr> <tr> <td>METER</td> <td>XMT OUT</td> </tr> <tr> <td>PA PWR</td> <td>OFF</td> </tr> <tr> <td>KEY</td> <td>EXT</td> </tr> <tr> <td>PEAK CLIP</td> <td>OFF</td> </tr> <tr> <td>PILOT CARR</td> <td>OFF</td> </tr> <tr> <td>MODE</td> <td>CW</td> </tr> <tr> <td>CHANNEL ENABLE</td> <td>A1 OFF</td> </tr> <tr> <td></td> <td>B1 OFF</td> </tr> <tr> <td></td> <td>B2 OFF</td> </tr> <tr> <td></td> <td>A2 OFF</td> </tr> <tr> <td>CONT</td> <td>LCL</td> </tr> </table> <p>b. Press PWR switch to ON position.</p> <p>c. Change frequency to 2001.0 kHz.</p> <p>d. Change frequency to 2000.0 kHz.</p> <p>e. Set KEY to LOCK.</p> <p>f. Plug phones into PHONES jack. Set PHONE switch to ALL CH. (Adjust level control to obtain comfortable listening level.)</p> <p>g. Set KEY to NORM.</p> <p>h. Connect a jumper between ground and the following pins on J15:</p> <p>J15-21</p>	PWR	Off	METER	XMT OUT	PA PWR	OFF	KEY	EXT	PEAK CLIP	OFF	PILOT CARR	OFF	MODE	CW	CHANNEL ENABLE	A1 OFF		B1 OFF		B2 OFF		A2 OFF	CONT	LCL	<p>Exciter fault indicator lit.</p> <p>Exciter fault indicator is off.</p> <p>Key indicator is off.</p> <p>Key indicator is lit.</p> <p>Exciter meter indicates off scale.</p> <p>Tone is present in phones.</p> <p>PA READY indicator is lit.</p>	<p>Check A2A3S17.</p> <p>Check control A10, power supply A1, and synthesizer output.</p> <p>Check control A10.</p> <p>Check LED status display A2A1.</p> <p>Check rf translator A9.</p> <p>Check transmit audio A4 (A1-B1).</p> <p>Check control A10 and LED status display A2A1.</p>
PWR	Off																										
METER	XMT OUT																										
PA PWR	OFF																										
KEY	EXT																										
PEAK CLIP	OFF																										
PILOT CARR	OFF																										
MODE	CW																										
CHANNEL ENABLE	A1 OFF																										
	B1 OFF																										
	B2 OFF																										
	A2 OFF																										
CONT	LCL																										

Table 5. HF-8014( ) Exciter Detailed Performance Test Procedures (Cont).

TEST	PROCEDURE	NORMAL INDICATION	IF INDICATION IS ABNORMAL																
2. (Cont)	<p>J15-5</p> <p>i. Connect a dc power supply set at +10 V dc through a 1-kilohm resistor to:</p> <p>J15-1</p> <p>J15-3</p> <p>J16-8</p> <p>j. Place MODE switch in ISB and CHANNEL ENABLE switches:</p> <p>A1 to LINE B1 to LINE A2 to LINE B2 to LINE</p> <p>k. Place MODE switch to AM.</p> <p>l. Place MODE switch to CW.</p> <p>m. Place PEAK CLIP switch to ON.</p> <p>n. Place PEAK CLIP switch to OFF.</p> <p>o. Place PILOT CARR switch to ON.</p> <p>p. Depress PWR switch to turn exciter OFF.</p>	<p>RF OUT indicator is lit.</p> <p>COUPLER FAULT indicator is lit.</p> <p>PA FAULT indicator is lit.</p> <p>PRESEL FAULT indicator is lit.</p> <p>ISB indicator is lit.</p> <p>A1 indicator is lit. B1 indicator is lit. A2 indicator is lit. B2 indicator is lit.</p> <p>AM indicator is lit.</p> <p>CW indicator is lit.</p> <p>PEAK CLIP indicator is lit.</p> <p>PILOT CARR indicator is lit.</p>	<p>Check control A10 and LED status display A2A1.</p> <p>Same as step h.</p> <p>Same as step h.</p> <p>Same as step h.</p> <p>Same as step h.</p> <p>Same as step h.</p> <p>Same as step h.</p> <p>Same as step h.</p> <p>Same as step h.</p> <p>Same as step h.</p>																
3. Frequency display (only for those exciters with frequency display A2A5)  (Cont)	<p>a. Set front panel controls as follows:</p> <table border="0" style="width: 100%;"> <tr> <td style="width: 50%;">PWR</td> <td>Off</td> </tr> <tr> <td>METER</td> <td>XMT OUT</td> </tr> <tr> <td>PA PWR</td> <td>OFF</td> </tr> <tr> <td>KEY</td> <td>EXT</td> </tr> <tr> <td>PEAK CLIP</td> <td>OFF</td> </tr> <tr> <td>PILOT CARR</td> <td>OFF</td> </tr> <tr> <td>MODE</td> <td>CW</td> </tr> <tr> <td>CHANNEL ENABLE</td> <td>A1 OFF B1 OFF</td> </tr> </table>	PWR	Off	METER	XMT OUT	PA PWR	OFF	KEY	EXT	PEAK CLIP	OFF	PILOT CARR	OFF	MODE	CW	CHANNEL ENABLE	A1 OFF B1 OFF		
PWR	Off																		
METER	XMT OUT																		
PA PWR	OFF																		
KEY	EXT																		
PEAK CLIP	OFF																		
PILOT CARR	OFF																		
MODE	CW																		
CHANNEL ENABLE	A1 OFF B1 OFF																		



Table 5. HF-8014( ) Exciter Detailed Performance Test Procedures (Cont).

TEST	PROCEDURE	NORMAL INDICATION	IF INDICATION IS ABNORMAL
<p>4. (Cont)</p> <p>(Cont)</p>	<p>d. Set FREQUENCY thumb wheels to 1600.0 kHz.</p> <p>e. Connect a jumper between ground and J15-24 (exciter tune). Observe rf voltmeter.</p> <p>f. Repeat step e for the following frequencies:</p> <p>4000.00 kHz</p> <p>8000.00 kHz</p> <p>16 000.00 kHz</p> <p>29 900.00 kHz</p> <p>g. Remove jumper between J15-24 and ground.</p> <p>h. Connect af signal generator to channel A1 line input on the rear panel.</p> <p>i. Set af signal generator to 900 Hz.</p> <p>j. Set METER switch to CH A1 AF (+3FS).</p> <p>k. Set MODE switch to ISB.</p> <p>l. Set CHANNEL ENABLE A1 switch to LINE.</p> <p>m. Adjust af signal generator output until exciter meter indicates compression (black segment on meter).</p> <p>n. Set FREQUENCY control to 8000.00 kHz.</p> <p>o. Set KEY to LOCK.</p> <p>p. Adjust output frequency of the af signal generator between 1100 and 900 Hz to obtain minimum reading on the rf voltmeter. Record af signal generator frequency.</p> <p>q. Set KEY to EXT.</p> <p>r. Connect af signal generator to channel B1 line input on rear panel.</p> <p>s. Set CHANNEL ENABLE A1 to OFF and B1 to LINE.</p>	<p>Rf voltmeter indicates +20.5 to +22.5 dB mW. Record rf voltmeter reading.</p> <p>Same as step e.</p> <p>Rf voltmeter indicates +4.5 to +5.5 dB of reading obtained at 8000.00 kHz in step f. Record this reading.</p>	<p>Replace channel A1 if A8.</p> <p>Same as step e.</p> <p>Replace channel A1 if A8 or transmit audio A4 (A1-B1).</p>

Table 5. HF-8014( ) Exciter Detailed Performance Test Procedures (Cont).

TEST	PROCEDURE	NORMAL INDICATION	IF INDICATION IS ABNORMAL														
4. (Cont)	<p>t. Set METER to CH B1 AF (+3FS).</p> <p>u. Adjust af signal generator output until exciter meter indicates compression (black segment of meter). Set af signal generator frequency to that recorded in step p.</p> <p>v. Set KEY to LOCK.</p> <p>w. Repeat steps q thru v for channels A2 and B2.</p> <p>x. Set KEY to EXT.</p> <p>y. Connect af signal generator to front panel MIC jack. Set af signal generator output level to 1 mV at 1 kHz.</p> <p>z. Set CHANNEL ENABLE B2 to OFF and A1 to MIC.</p> <p>aa. Set KEY to LOCK.</p> <p>ab. Press PWR switch one time to turn exciter off.</p>	<p>Rf voltmeter indicates within <math>\pm 0.5</math> dB of reading obtained in step p.</p> <p>Same as step v.</p> <p>Same as step v.</p>	<p>Same as step p.</p> <p>Replace channel A7 if A8 or transmit audio A3 (A2-B2).</p> <p>Same as step p.</p>														
<p>5. Multiplex combiner gain reduction</p> <p>(Cont)</p>	<p>a. Set front panel controls as follows:</p> <table border="0" style="margin-left: 20px;"> <tr><td>PWR</td><td>On</td></tr> <tr><td>METER</td><td>XMT OUT</td></tr> <tr><td>PA PWR</td><td>OFF</td></tr> <tr><td>KEY</td><td>EXT</td></tr> <tr><td>PEAK CLIP</td><td>OFF</td></tr> <tr><td>PILOT CARR</td><td>OFF</td></tr> <tr><td>MODE</td><td>CW</td></tr> </table> <p>b. Set MODE to ISB. Connect rf voltmeter through a 50-ohm probe and 0 - 50 dB attenuator to XMT OUT jack J-22 on rear panel.</p> <p>c. Set CHANNEL ENABLE to A1 LINE and FREQUENCY to 8000.0 kHz.</p>	PWR	On	METER	XMT OUT	PA PWR	OFF	KEY	EXT	PEAK CLIP	OFF	PILOT CARR	OFF	MODE	CW		
PWR	On																
METER	XMT OUT																
PA PWR	OFF																
KEY	EXT																
PEAK CLIP	OFF																
PILOT CARR	OFF																
MODE	CW																







Table 5. HF-8014( ) Exciter Detailed Performance Test Procedures (Cont).

TEST	PROCEDURE	NORMAL INDICATION	IF INDICATION IS ABNORMAL
7. (Cont)	<p>b. Connect audio voltmeter across a 600-ohm load connected to the PHONES jack on the front panel.</p> <p>c. Set PHONE level control fully cw (maximum). Press PWR switch to turn exciter on.</p> <p>d. Set FREQUENCY to 8000.0 kHz.</p> <p>e. Set METER switch to monitor audio of channel under test.</p> <p>f. Connect audio signal generator with a 1-kHz output to rear panel audio line input of the channel under test.</p> <p>g. Connect 50-ohm load to the XMT OUT jack J22 on rear panel.</p> <p>h. Adjust the output level of the audio signal generator to cause the exciter meter to indicate compression (black segment of meter).</p> <p>i. Repeat steps e thru h for each channel below:</p> <p>Channel A2</p> <p>Channel B1</p> <p>Channel B2</p> <p>ALL CH</p> <p>j. Press PWR switch and turn exciter off.</p>	<p>Audio voltmeter reads NLT +10 dB mW.</p> <p>Same as step h.</p> <p>Same as step h.</p> <p>Same as step h.</p> <p>Same as step h.</p>	<p>Replace transmit audio A4 (A1-B1).</p> <p>Replace transmit audio A3 (A2-B2) or A4 (A1-B1).</p> <p>Replace transmit audio A4 (A2-B2) or A3 (A1-B1).</p> <p>Replace transmit audio A4 (A2-B2) or A3 (A1-B1).</p>
8. In-band inter-modulation/ carrier suppression  (Cont)	<p>a. Set front panel controls as follows:</p> <p>PWR                    On</p> <p>METER                XMT OUT</p> <p>PA PWR               OFF</p> <p>KEY                    EXT</p> <p>PEAK CLIP           OFF</p>		

Table 5. HF-8014( ) Exciter Detailed Performance Test Procedures (Cont).

TEST	PROCEDURE	NORMAL INDICATION	IF INDICATION IS ABNORMAL
<p>8. (Cont)</p> <p>(Cont)</p>	<p>PILOT CARR            OFF</p> <p>MODE                    ISB</p> <p>CHANNEL ENABLE    A1 OFF</p> <p>                                  B1 OFF</p> <p>                                  B2 OFF</p> <p>                                  A2 OFF</p> <p>CONT                    LCL</p> <p>b. Connect a spectrum analyzer thru a 0 - 50-dB attenuator to XMT OUT jack, J-22, on rear panel.</p> <p>c. Connect 2-tone generator to rear panel audio input lines of channel under test, as indicated in table, at frequencies of 900 and 1100 Hz. <i>ADJUST THE CIP OF THE 2 TONE GENERATOR TO CAUSE THE EXCITER METRE TO INDICATE COMPRESSION. (BLACK SEGMENT OF METRE)</i></p> <p><b>Note</b> 2-tone generator must have a low-distortion output. If two audio signal generators are used they must be isolated with 20-dB attenuators and connected through a hybrid transformer.</p> <p>d. Set CHANNEL ENABLE switch of channel under test to LINE.</p> <p>e. Set KEY to LOCK. Set unit frequency to frequency listed in table.</p> <p>f. Set rf output into spectrum analyzer at 200-mW pep (1.6 V per tone) by adjusting 0 - 50 dB attenuator.</p> <p>g. Calibrate spectrum analyzer and measure third order intermodulation distortion and carrier suppression for each channel and frequency listed.</p> <p><b>Note</b></p> <p>Third order intermodulation frequencies = <math>2f_1 \pm f_2</math> or <math>2f_2 \pm f_1</math> where <math>f_1</math> and <math>f_2</math> are applied tone frequencies.</p>	<p>Distortion is within tolerance shown in table.</p>	<p>Replace channel B2 if A5, channel A2 if A6, channel B1 if A7, or channel A1 if A8, as applicable.</p>

AD-1





Table 5. HF-8014( ) Exciter Detailed Performance Test Procedures (Cont).

TEST	PROCEDURE	NORMAL INDICATION	IF INDICATION IS ABNORMAL														
10. (Cont)	<p>b. Connect rf voltmeter through a 50-ohm probe to XMT OUT jack J-22 on rear panel.</p> <p>c. Connect the dc power supply through a 1-kΩ resistor to J15-23 (TGC input) (A10 TP6).</p> <p>d. Press PWR switch to turn exciter on. Set FREQUENCY to 10 000.0 kHz.</p> <p>e. Set output of the dc power supply to -5.00 V dc.</p> <p>f. Connect a jumper between A10TP3 (on control A10) and ground. Record dB mW reading on rf voltmeter.</p> <p>g. Lower output of the dc power supply until an increase is noted on rf voltmeter.</p> <p>h. Set the dc power supply at -5.00 V dc.</p> <p>i. Increase output of the dc power supply (in a negative direction) until a decrease is noted on rf voltmeter.</p> <p style="text-align: center;"><b>Caution</b></p> <p>Do not let dc power supply output exceed -12.0 V dc in following step.</p> <p>j. Continue to increase output of the dc power supply (in a negative direction) until maximum decrease in rf output is reached.</p> <p>k. Press PWR switch to turn exciter off.</p>	<p>Power supply output is -4.85 to -4.65 V dc.</p> <p>Power supply output is -5.35 to -5.15 V dc.</p> <p>Rf output is -24 to -30 dB down from reading obtained in step f.</p>	<p>Replace control A10.</p> <p>Replace control A10.</p> <p>Replace control A10.</p>														
<p>11. ALC</p> <p>(Cont)</p>	<p>a. Set front panel controls as follows:</p> <table border="0" style="width: 100%;"> <tr> <td style="width: 50%;">PWR</td> <td>On</td> </tr> <tr> <td>METER</td> <td>XMT OUT</td> </tr> <tr> <td>PA PWR</td> <td>OFF</td> </tr> <tr> <td>KEY</td> <td>EXT</td> </tr> <tr> <td>PEAK CLIP</td> <td>OFF</td> </tr> <tr> <td>PILOT CARR</td> <td>OFF</td> </tr> <tr> <td>MODE</td> <td>CW</td> </tr> </table>	PWR	On	METER	XMT OUT	PA PWR	OFF	KEY	EXT	PEAK CLIP	OFF	PILOT CARR	OFF	MODE	CW		
PWR	On																
METER	XMT OUT																
PA PWR	OFF																
KEY	EXT																
PEAK CLIP	OFF																
PILOT CARR	OFF																
MODE	CW																

★









Table 5. HF-8014( ) Exciter Detailed Performance Test Procedures (Cont).

TEST	PROCEDURE	NORMAL INDICATION	IF INDICATION IS ABNORMAL																																																	
14. (Cont)	<p>c. Set KEY to LOCK and check frequency accuracy at each of the following frequencies:</p> <table border="1" data-bbox="370 595 1122 1218"> <thead> <tr> <th rowspan="3">FREQUENCY KHZ</th> <th colspan="3">FREQUENCY COUNTER DISPLAY</th> </tr> <tr> <th rowspan="2">KHZ</th> <th>WITH TCXO</th> <th>WITH OVEN STD</th> </tr> <tr> <th>±HZ</th> <th>*±HZ</th> </tr> </thead> <tbody> <tr> <td>10 000.0</td> <td>10 000.00</td> <td>5.0</td> <td>0.34</td> </tr> <tr> <td>11 111.1</td> <td>11 111.10</td> <td>5.5</td> <td>0.38</td> </tr> <tr> <td>22 222.2</td> <td>22 222.20</td> <td>11.1</td> <td>0.75</td> </tr> <tr> <td>3 333.3</td> <td>3 333.30</td> <td>1.6</td> <td>0.11</td> </tr> <tr> <td>4 444.4</td> <td>4 444.40</td> <td>2.2</td> <td>0.15</td> </tr> <tr> <td>5 555.5</td> <td>5 555.50</td> <td>2.7</td> <td>0.18</td> </tr> <tr> <td>6 666.6</td> <td>6 666.60</td> <td>3.3</td> <td>0.23</td> </tr> <tr> <td>7 777.7</td> <td>7 777.70</td> <td>3.9</td> <td>0.26</td> </tr> <tr> <td>8 888.8</td> <td>8 888.80</td> <td>4.4</td> <td>0.30</td> </tr> <tr> <td>29 999.9</td> <td>29 999.90</td> <td>15.0</td> <td>1.01</td> </tr> </tbody> </table> <p>*This accuracy is only for those exciters equipped with optional oven standard A29.</p> <p>d. Press PWR switch to turn exciter OFF.</p>	FREQUENCY KHZ	FREQUENCY COUNTER DISPLAY			KHZ	WITH TCXO	WITH OVEN STD	±HZ	*±HZ	10 000.0	10 000.00	5.0	0.34	11 111.1	11 111.10	5.5	0.38	22 222.2	22 222.20	11.1	0.75	3 333.3	3 333.30	1.6	0.11	4 444.4	4 444.40	2.2	0.15	5 555.5	5 555.50	2.7	0.18	6 666.6	6 666.60	3.3	0.23	7 777.7	7 777.70	3.9	0.26	8 888.8	8 888.80	4.4	0.30	29 999.9	29 999.90	15.0	1.01		Check synthesizer and frequency switchboard A2A3.
FREQUENCY KHZ	FREQUENCY COUNTER DISPLAY																																																			
	KHZ		WITH TCXO	WITH OVEN STD																																																
		±HZ	*±HZ																																																	
10 000.0	10 000.00	5.0	0.34																																																	
11 111.1	11 111.10	5.5	0.38																																																	
22 222.2	22 222.20	11.1	0.75																																																	
3 333.3	3 333.30	1.6	0.11																																																	
4 444.4	4 444.40	2.2	0.15																																																	
5 555.5	5 555.50	2.7	0.18																																																	
6 666.6	6 666.60	3.3	0.23																																																	
7 777.7	7 777.70	3.9	0.26																																																	
8 888.8	8 888.80	4.4	0.30																																																	
29 999.9	29 999.90	15.0	1.01																																																	
15. Remote control (HF-8014A only)  (Cont)	<p>a. Set front panel controls as follows:</p> <table border="0" data-bbox="402 1451 786 1906"> <tr> <td>PWR</td> <td>Off</td> </tr> <tr> <td>METER</td> <td>XMT OUT</td> </tr> <tr> <td>PA PWR</td> <td>OFF</td> </tr> <tr> <td>KEY</td> <td>EXT</td> </tr> <tr> <td>PEAK CLIP</td> <td>OFF</td> </tr> <tr> <td>PILOT CARR</td> <td>OFF</td> </tr> <tr> <td>MODE</td> <td>CW</td> </tr> <tr> <td>CHANNEL ENABLE</td> <td>A1 OFF</td> </tr> <tr> <td></td> <td>B1 OFF</td> </tr> <tr> <td></td> <td>B2 OFF</td> </tr> <tr> <td></td> <td>A2 OFF</td> </tr> <tr> <td>CONT</td> <td>LCL</td> </tr> </table>	PWR	Off	METER	XMT OUT	PA PWR	OFF	KEY	EXT	PEAK CLIP	OFF	PILOT CARR	OFF	MODE	CW	CHANNEL ENABLE	A1 OFF		B1 OFF		B2 OFF		A2 OFF	CONT	LCL																											
PWR	Off																																																			
METER	XMT OUT																																																			
PA PWR	OFF																																																			
KEY	EXT																																																			
PEAK CLIP	OFF																																																			
PILOT CARR	OFF																																																			
MODE	CW																																																			
CHANNEL ENABLE	A1 OFF																																																			
	B1 OFF																																																			
	B2 OFF																																																			
	A2 OFF																																																			
CONT	LCL																																																			

Table 5. HF-8014( ) Exciter Detailed Performance Test Procedures (Cont).

TEST	PROCEDURE	NORMAL INDICATION	IF INDICATION IS ABNORMAL
<p>15. (Cont)</p> <p>(Cont)</p>	<p>b. Connect a compatible exciter control to unit under test.</p> <p>c. Set unit under test PWR to ON and initiate a FREQUENCY change to clear the EXCITER fault.</p> <p>d. Set exciter control PWR to ON and make changes to the following exciter control front panel controls:</p> <p>MODE switch CHANNEL ENABLE switches PILOT CARR switch PEAK CLIP switch KEY switch</p> <p>e. Set the exciter control front panel controls as follows:</p> <p>PWR to ON CONT to NORM PEAK CLIP to OFF PILOT CARR to OFF CHANNEL ENABLE A1 to OFF A2 to OFF B1 to OFF B2 to OFF KEY to NORM MODE to AM</p> <p>f. Set unit under test CONT switch to REM.</p> <p>g. Make changes to the following unit under test controls:</p> <p>MODE switch PEAK CLIP switch PILOT CARR switch KEY switch FREQUENCY KHZ switches</p>	<p>EXCITER fault indicator is extinguished.</p> <p>Changing of exciter control front panel controls has no effect on the unit under test displays/indicators.</p> <p>Faults do not light. AM indicator lights.</p> <p>Changing of unit under test controls has no effect on the unit under test displays/indicators.</p>	<p>Check control A10 and LED status display A2A5.</p> <p>Check parallel input A11, parallel output A12, and serial interface A13.</p> <p>Same as step d.</p> <p>Same as step d.</p>

Table 5. HF-8014( ) Exciter Detailed Performance Test Procedures (Cont).

TEST	PROCEDURE	NORMAL INDICATION	IF INDICATION IS ABNORMAL														
15. (Cont)	<p>h. Change exciter control FREQUENCY switches.</p> <p>i. Place exciter control PILOT CARR switch to ON.</p> <p>j. Place exciter control PEAK CLIP to ON.</p> <p>k. Place exciter control MODE switch to ISB.</p> <p>l. Place exciter control CHANNEL ENABLE switches:</p> <p style="padding-left: 40px;">A1 to LINE</p> <p style="padding-left: 40px;">A2 to LINE</p> <p style="padding-left: 40px;">B1 to LINE</p> <p style="padding-left: 40px;">B2 to LINE</p> <p>m. Turn off power to exciter control and unit under test.</p>	<p>Unit under test display changes with change in setting of FREQUENCY switches.</p> <p>Unit under test PILOT CARR indicator lights.</p> <p>Unit under test PEAK CLIP indicator lights.</p> <p>Unit under test ISB indicator lights.</p> <p>The following unit under test ISB MODE indicators light:</p> <p>A1</p> <p>A2</p> <p>B1</p> <p>B2</p>	<p>Check serial interface A13 and parallel output A12.</p> <p>Same as step h.</p> <p>Same as step h.</p> <p>Same as step h.</p> <p>Same as step h.</p>														
<p>16. Frequency standard switch</p> <p>(Cont)</p>	<p style="text-align: center;"><b>Note</b></p> <p>This test is only required on those exciters equipped with frequency standard switch A30.</p> <p>a. Set front panel controls as follows:</p> <table style="width: 100%; border: none;"> <tr> <td style="width: 50%;">PWR</td> <td>Off</td> </tr> <tr> <td>METER</td> <td>XMT OUT</td> </tr> <tr> <td>PA PWR</td> <td>OFF</td> </tr> <tr> <td>KEY</td> <td>EXT</td> </tr> <tr> <td>PEAK CLIP</td> <td>OFF</td> </tr> <tr> <td>PILOT CARR</td> <td>OFF</td> </tr> <tr> <td>MODE</td> <td>CW</td> </tr> </table> <p>b. Connect rf signal generator to EXT STD J23 on rear panel.</p>	PWR	Off	METER	XMT OUT	PA PWR	OFF	KEY	EXT	PEAK CLIP	OFF	PILOT CARR	OFF	MODE	CW		
PWR	Off																
METER	XMT OUT																
PA PWR	OFF																
KEY	EXT																
PEAK CLIP	OFF																
PILOT CARR	OFF																
MODE	CW																

Table 5. HF-8014( ) Exciter Detailed Performance Test Procedures (Cont).

TEST	PROCEDURE	NORMAL INDICATION	IF INDICATION IS ABNORMAL												
16. (Cont)	<p>c. Connect frequency counter to XMT OUT jack J22 on rear panel.</p> <p>d. Press PWR switch to turn exciter on.</p> <p>e. Set exciter FREQUENCY KHZ to 10 000.00 and set KEY to LOCK.</p> <p>f. Set frequency switch on frequency standard switch A30 to 100 kHz.</p> <p>g. Set rf signal generator to 0.5-V rms output at 100 kHz.</p> <p>h. Vary rf signal generator output frequency <math>\pm 1</math> Hz.</p> <p>i. Disconnect rf signal generator from J23.</p> <p>j. Repeat steps f thru i with the following test setup.</p> <table border="1" style="width: 100%; margin: 10px 0;"> <thead> <tr> <th style="width: 33%;">RF SIGNAL GENERATOR FREQUENCY</th> <th style="width: 33%;">FREQUENCY STANDARD SWITCH SETTING</th> <th style="width: 33%;">RF SIGNAL GENERATOR VARIANCE</th> </tr> </thead> <tbody> <tr> <td>1 MHz</td> <td>1 MHz</td> <td><math>\pm 10</math> Hz</td> </tr> <tr> <td>5 MHz</td> <td>5 MHz</td> <td><math>\pm 50</math> Hz</td> </tr> </tbody> </table>	RF SIGNAL GENERATOR FREQUENCY	FREQUENCY STANDARD SWITCH SETTING	RF SIGNAL GENERATOR VARIANCE	1 MHz	1 MHz	$\pm 10$ Hz	5 MHz	5 MHz	$\pm 50$ Hz	<p>Frequency counter reads 10 000.00 kHz.</p> <p>Frequency displayed on frequency counter varies <math>\pm 100</math> Hz.</p> <p>Frequency counter continues to indicate 10 000.0 kHz.</p>	<p>Replace frequency standard switch A30.</p> <p>Same as step g.</p> <p>Same as step g.</p>			
RF SIGNAL GENERATOR FREQUENCY	FREQUENCY STANDARD SWITCH SETTING	RF SIGNAL GENERATOR VARIANCE													
1 MHz	1 MHz	$\pm 10$ Hz													
5 MHz	5 MHz	$\pm 50$ Hz													
	<p>k. Connect rf vtvm with a 50-ohm probe to 100-kHz outjack J56 on rear panel.</p> <p>l. Press PWR switch to turn exciter off.</p>	<p>Meter indicates NLT 1.0 V rms.</p>	<p>Same as step g.</p>												
17. Tune start lockout  (Cont)	<div style="border: 1px solid black; padding: 2px; width: fit-content; margin: 0 auto 10px auto;"> <p style="margin: 0;"><b>Note</b></p> </div> <p>This test is only required on those exciters strapped for tune start lockout.</p> <p>a. Set front panel controls as follows:</p> <table style="width: 100%; margin-left: 20px;"> <tr><td>PWR</td><td>Off</td></tr> <tr><td>METER</td><td>XMT OUT</td></tr> <tr><td>PA PWR</td><td>OFF</td></tr> <tr><td>KEY</td><td>EXT</td></tr> <tr><td>PEAK CLIP</td><td>OFF</td></tr> <tr><td>PILOT CARR</td><td>OFF</td></tr> </table>	PWR	Off	METER	XMT OUT	PA PWR	OFF	KEY	EXT	PEAK CLIP	OFF	PILOT CARR	OFF		
PWR	Off														
METER	XMT OUT														
PA PWR	OFF														
KEY	EXT														
PEAK CLIP	OFF														
PILOT CARR	OFF														

Table 5. HF-8014( ) Exciter Detailed Performance Test Procedures (Cont).

TEST	PROCEDURE	NORMAL INDICATION	IF INDICATION IS ABNORMAL
17. (Cont)	<p>MODE CW</p> <p>CHANNEL ENABLE A1 OFF B1 OFF B2 OFF A2 OFF</p> <p>CONT LCL</p> <p>b. Place control A10 on an extender. Ensure that tune start jumper clip is connected to pins 1 and 2 (refer to figure 3).</p> <p>c. Press PWR switch to turn exciter on.</p> <p>d. Set FREQUENCY to 8000.0 kHz.</p> <p>e. Connect dvm to A10TP10.</p> <p>f. Connect +10-V dc signal to A10P1-30 through a 1-kΩ resistor.</p> <p>g. Initiate three frequency changes to attempt to clear PA FAULT.</p> <p>h. Remove +10-V dc signal from A10P1-30.</p> <p>i. Depress PWR switch twice to turn power off and back on.</p> <p>j. Initiate a frequency change to clear the EXCITER FAULT.</p> <p>k. Press PWR switch to turn exciter off.</p>	<p>Dvm indicates logic 0 (0.1 V dc).</p> <p>PA FAULT indicator lights.</p> <p>After third fault clearing attempt, dvm indicates a logic 1 (+5.0 V dc).</p> <p>Dvm continues to indicate a logic 1.</p> <p>Dvm indicates a logic 0.</p>	<p>Replace control A10.</p> <p>Same as step f.</p> <p>Same as step f.</p> <p>Same as step f.</p>

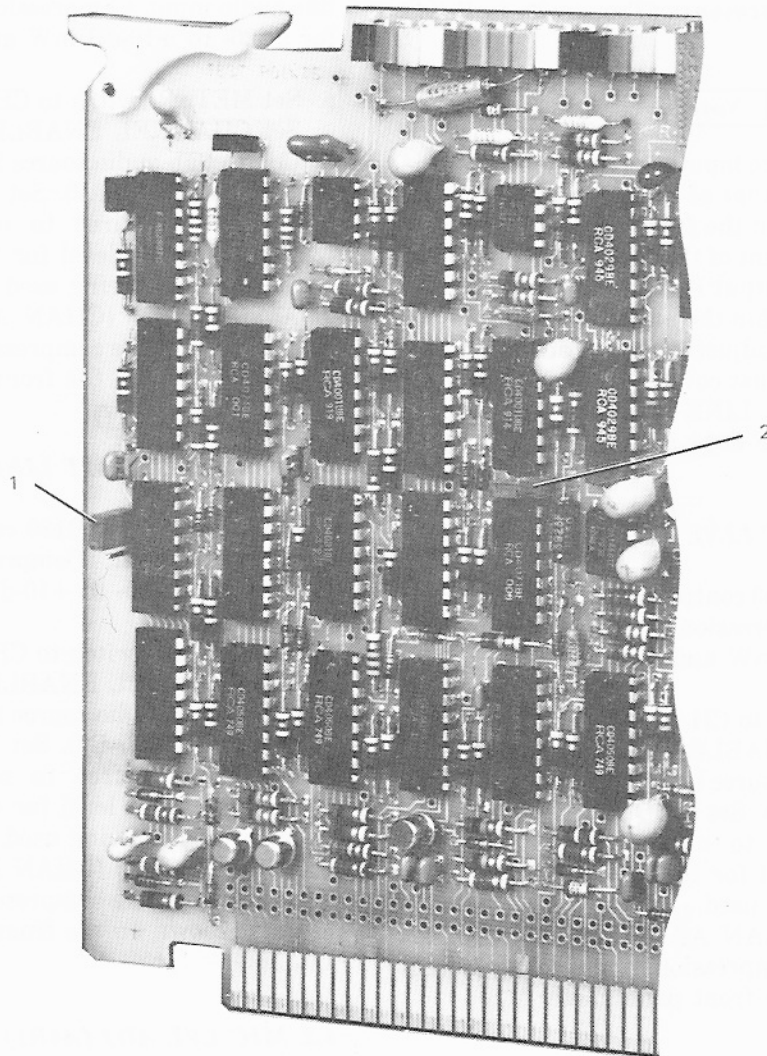

NOTES:

1. TUNE START JUMPER CLIP.
2. TGC CLOCK JUMPER CLIP.
3. BOTH JUMPER CLIPS ARE, AS SHOWN, CONNECTED FOR NORMAL OPERATION..

TPA-2965-017

*Control A10, Jumper Clip Location  
Figure 3*



#### 4. ALIGNMENT/ADJUSTMENT

Procedures in this section are instructions for properly aligning the exciter. It is assumed that no malfunctions exist in the exciter when these procedures are performed. If a malfunction is suspected, refer to detailed performance test procedures for troubleshooting information. All other adjustments are made in card maintenance and repair.

##### 4.1 Line Audio Adjustments (Transmit Audio A3 and A4)

**Note**

Transmit line audio inputs are within the 15-dB compression range of the audio amplifier if the indication on the front panel meter is in the black segment of the meter with audio applied. The rf output is constant when the audio input is within the indicated compression range. These adjustments are accessible through the top dust cover. (Refer to figure 4.) Channel RCV LINE ADJ are not applicable to the HF-8014 and HF-8014A exciters.

##### 4.1.1 CHAN A1 XMT LINE ADJ (A4R53)

Variable resistor A4R53 controls channel A1 transmit line audio input. Compression threshold is adjustable for a -20- to +10-dB mW audio input.

- a. Set METER switch to CH A1 AF (+3FS) position. Set CHANNEL ENABLE A1 switch to LINE.
- b. Connect an audio source between TB<sub>1</sub>-1 and TB<sub>1</sub>-2 (XMT AF 600Ω-A1). Set MODE switch to ISB.
- c. Set audio source to nominal frequency and nominal audio level for the application in which the exciter is being used.
- d. Adjust A4R53 (CHAN A1 XMT LINE ADJ) for midrange of the compression range (darkened segment shown on the front panel meter).

##### 4.1.2 CHAN B1 XMT LINE ADJ (A4R130)

Variable resistor A4R130 controls channel B1 transmit audio input. Compression threshold is adjustable for a -20- to +10-dB mW audio input.

- a. Set METER switch to CH B1 AF (+3FS) position and CHANNEL ENABLE B1 switch to LINE.
- b. Connect an audio source between TB<sub>2</sub>-3 and TB<sub>2</sub>-4 (XMT AF 600Ω-B1). Set MODE switch to ISB.

- c. Set audio source to nominal frequency and nominal audio level for the application in which the exciter is being used.
- d. Adjust A4R130 (CHAN B1 XMT LINE ADJ) for midrange of the compression range (darkened segment shown on the front panel meter).

##### 4.1.3 CHAN A2 XMT LINE ADJ (A3R53)

Variable resistor A3R53 controls channel A2 transmit line audio input. Compression threshold is adjustable for a -20- to +10-dB mW audio input.

- a. Set METER switch to CH A2 AF (+3FS) position. Set CHANNEL ENABLE A2 switch to LINE.
- b. Connect an audio source between TB<sub>1</sub>-1 and TB<sub>1</sub>-2 (XMT AF 600Ω-A2). Set MODE switch to ISB.
- c. Set audio source to nominal frequency and nominal audio level for the application in which the exciter is being used.
- d. Adjust A3R53 (CHAN A2 XMT LINE ADJ) for midrange of the compression range (darkened segment shown on the front panel meter).

##### 4.1.4 CHAN B2 XMT LINE ADJ (A3R130)

Variable resistor A3R130 controls channel B2 transmit audio input. Compression threshold is adjustable for a -20- to +10-dB mW audio input.

- a. Set METER switch to CH B2 AF (+3FS) position and CHANNEL ENABLE B2 to LINE.
- b. Connect an audio source between TB<sub>2</sub>-3 and TB<sub>2</sub>-4 (XMT AF 600Ω-B2). Set MODE switch to ISB.
- c. Set audio source to nominal frequency and nominal audio level for the application in which the exciter is being used.
- d. Adjust A3R130 (CHAN B2 XMT LINE ADJ) for midrange of the compression range (darkened segment shown on the front panel meter).

##### 4.2 MIC LVL ADJ (A4R1) (Transmit Audio A4)

**Note**

Microphone level is set so that when spoken into, in a normal voice, it causes the front panel meter to indicate between -5 to 0-dB mW. Avoid setting the microphone gain too high to prevent excessive background noise from being transmitted. This adjustment is accessible through the top dust cover. (Refer to figure 4.)

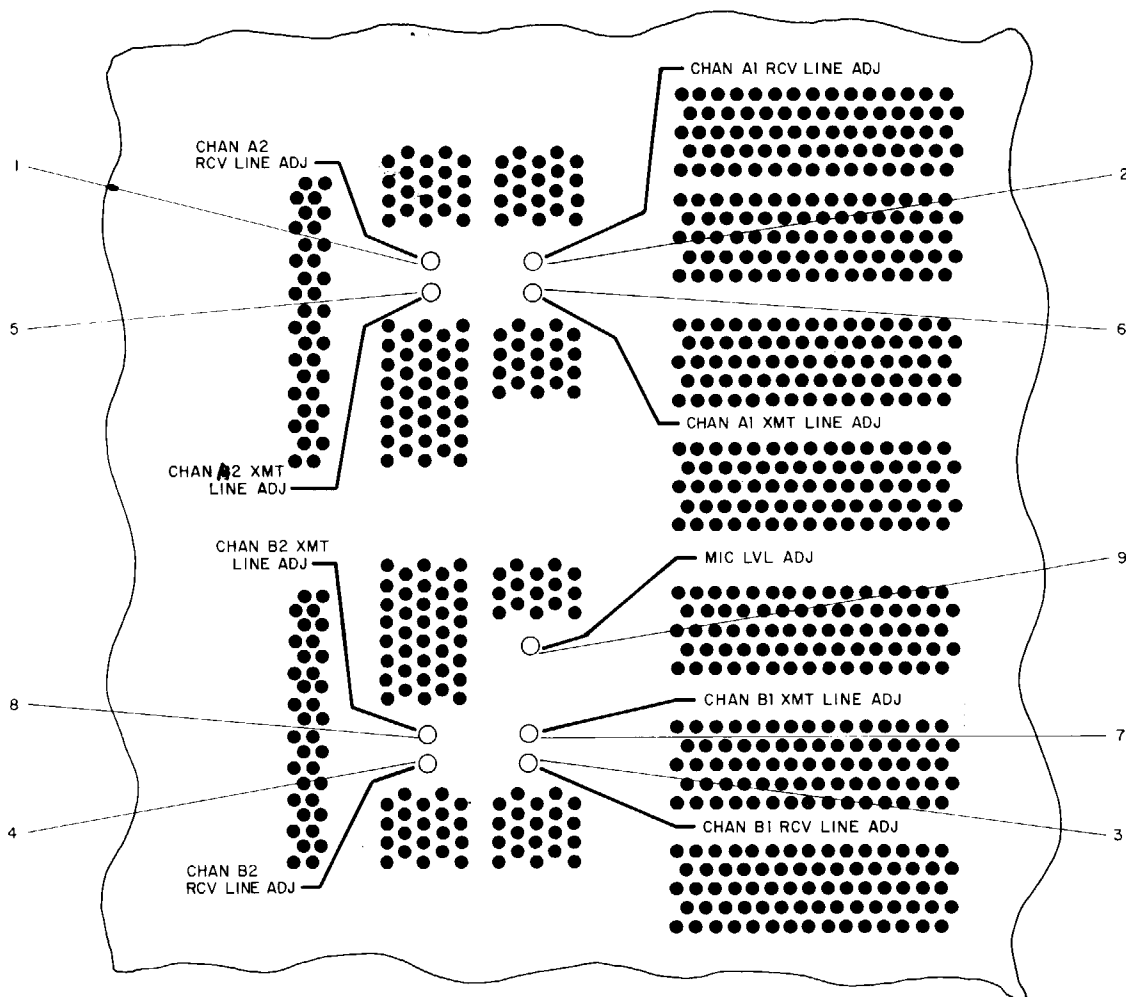

TPA-2719-014

Top Cover Adjustments  
Figure 4

Variable resistor A4R1 (MIC LVL ADJ) adjusts the microphone input audio level which permits considerable variation in speaking levels and microphone-to-mouth distance while still delivering full rf output. Microphone compression range is 30 dB.

- a. Set METER switch to CH A1 AF (+3FS) position. Set CHANNEL ENABLE A1 switch to MIC. Set MODE switch in any position except CW.
- b. Press ptt key and speak into microphone in a normal voice.
- c. While speaking into microphone (keyed), adjust A4R1 (MIC LVL ADJ) into area between -5 and 0 dB (as read on front panel meter).
- d. Release ptt key.

#### 4.3 Transmit RF Output Level Adjustments (Channel A1 IF A8)

**Note**

Transmit rf output level adjustments are accessible only by extending channel A1 if A8. If any of the following adjustments cannot be made, refer to channel A1 if instructions section of this instruction book.

##### 4.3.1 Tune Power Adjustment

- a. Connect an rf voltmeter (with a 50-ohm load) through a 6-dB pad to XMT OUT jack J22 on rear panel.

- b. Apply a ground to J15-24 (or A10TP3) to enable tune power.
- c. Set KEY switch to LOCK.
- d. Note rf voltmeter reading (record this reading for use in other power adjustments); it should be NLT +14 dB mW for any frequency 1.6 to 29.9999 MHz.
- e. If rf output is too low, adjust A8R152 for an rf output of NLT +14 dB mW. Repeat step d.
- f. Set KEY switch to NORM.
- g. Remove J15-24 (or A10TP3) ground.

#### 4.3.2 ISB Power Adjustment

- a. Perform tune power adjustment (paragraph 4.3.1).
- b. Set MODE switch to ISB.
- c. Set METER switch to CH A1 AF (+3FS) and CHANNEL ENABLE A1 to LINE.
- d. Connect an audio oscillator XMT AF 600Ω-CH A1 terminals TB~~1~~-1, ~~1~~-2 on rear panel.
- e. Set KEY switch to LOCK; adjust audio oscillator output for 700 to 1100 Hz and in the compression range as indicated on the front panel meter.
- f. Adjust audio oscillator to frequency between 700 and 1100 Hz that produces a minimum rf output as indicated on rf voltmeter.
- g. Note rf voltmeter reading; it should be NLT 5 dB greater than reading noted in step 4.3.1.d.
- h. If rf output is too low, adjust A8R77 for an rf output of 5 dB greater than the reading noted in step 4.3.1.d.
- i. Set KEY switch to NORM.
- j. Remove audio oscillator from TB~~1~~-1, ~~1~~-2.

#### 4.3.3 AM Power Adjustment

- a. Perform tune power adjustment (paragraph 4.3.1).
- b. Set MODE switch to AM.
- c. Set KEY switch to LOCK.
- d. Note rf voltmeter reading; it should be 2 to 4 dB less than the reading noted in step 4.3.1.d.
- e. If rf output is out of range, adjust A8R142 for an rf output of 3 dB below the reading noted in step 4.3.1.d.
- f. Set KEY switch to NORM.

#### 4.3.4 CW Power Adjustment

- a. Perform tune power adjustment (paragraph 4.3.1).
- b. Set MODE switch to CW.
- c. Set KEY switch to LOCK.
- d. Note rf voltmeter reading; it should be NLT 5 dB greater than the reading noted in step 4.3.1.d.
- e. If rf output is too low, adjust A8R168 for an rf output 5 dB above the reading noted in step 4.3.1.d.
- f. Set KEY switch to NORM.

#### 4.3.5 Pilot Carrier Adjustment

- a. Perform tune power adjustment (paragraph 4.3.1).
- b. Set MODE switch to ISB and PILOT CARR switch to ON. Set CHANNEL ENABLE A1 to LINE.
- c. Set KEY switch to LOCK.
- d. Note rf voltmeter reading; it should be 16 to 18 dB less than the reading noted in step 4.3.1.d.

**Note**

A level of -17 dB from tune power level of step 4.4.1.d corresponds to -20 dB from pep when the exciter is TGC/ALC controlled by the pa. The pilot carrier may be adjusted to any level over the range of -13 to -23 dB from pep.

- e. If rf output is out of range, adjust A8R148 for an rf output 17 dB below the reading noted in step 4.3.1.d or to the level predetermined by the installation.
- f. Set KEY switch to NORM.

#### 4.4 CW Hang Time Adjustment (Control A10)

**Note**

CW hang time is the time that the exciter/power amplifier circuits remain keyed after the release of the input key when in CW mode. The CW hang time determines the receive break-in characteristics. The variable resistor for this adjustment is accessible by removing the top cover.

The CW hang time is factory-set for 250 ms (0.25 s) nominal. If the operator desires a longer or shorter CW hang time, it may be adjusted as follows, however, do not shorten the CW hang time so that the tr relay in the pa operates excessively during normal CW keying.

- a. Set MODE switch to CW. Set the associated receiver to receive an on-the-air CW keying.
- b. Operate the CW key. Adjust A10R46 to obtain the desired hang time characteristic.

#### 4.5 Frequency Adjustment (Synthesizer Reference A16)

**Note**

The trim capacitor for this adjustment is accessible through a hole in the top of the shield can on the synthesizer reference A16.

The accuracy of the frequency counter used for this adjustment must be  $\pm 1$  Hz at 10 MHz.

- a. Connect a frequency counter through a 6-dB pad to XMT OUT jack 22 on the rear panel.
- b. Set MODE switch to CW and FREQUENCY KHZ to 10 000.0(0).
- c. Set KEY switch to LOCK.
- d. Frequency output should read 10.0000 MHz  $\pm$ 5 Hz.
- e. If step d is out of tolerance, adjust A16C1 for 10.0000 MHz  $\pm$ 1 Hz.

**Note**

After a period of time (several years), trim capacitor A16C1 may not have sufficient range to restore frequency as required. If not, refer to testing/troubleshooting paragraph in synthesizer reference A16 instructions section of this instruction book.

#### 4.6 Meter Adjustments

##### 4.6.1 Transmit Audio Meter Adjustment (Transmit Audio A4)

**Note**

The variable resistors for these adjustments are accessible by extending transmit audio A4 (A1-B1).

- a. Perform line audio adjustments according to paragraphs 4.1.1 and 4.1.2.
- b. Set METER switch to CH A1 AF (+3FS) position. Set CHANNEL ENABLE A1 to LINE.
- c. Connect an audio source between TB2-1 and TB2-2 (XMT AF 600 $\Omega$ -A1).
- d. Set audio source to nominal frequency and nominal audio level for the application in which the exciter is being used.
- e. Set KEY switch to LOCK.
- f. Connect an audio voltmeter to A4TP3; note the audio voltmeter level; it should be 30  $\pm$ 0.5 mV rms.
- g. Adjust audio source output level downward until there is a sharp drop in the audio voltmeter reading. Slowly increase the audio source output level until the audio voltmeter reading just flattens out. Note the audio source output level.
- h. Increase the audio source output level by 15 dB. Adjust A4R88 for 0-dB reading on front panel meter, using the +3 DBM full-scale markings.
- i. Set KEY switch to NORM.
- j. Set METER switch to CH B1 AF (+3FS) position and CHANNEL ENABLE B1 to LINE.
- k. Connect an audio source between TB2-3 and TB2-4 (XMT AF 600 $\Omega$ -B1).

- l. Set audio source to nominal frequency and nominal audio level for the application in which the exciter is being used.
- m. Set KEY switch to LOCK.
- n. Connect an audio voltmeter to A4TP5; note the audio voltmeter level; it should be 30  $\pm$ 0.5 mV rms.
- o. Adjust audio source output level downward until there is a sharp drop in the audio voltmeter reading. Slowly increase the audio source output level until the audio voltmeter reading just flattens out; note the audio source output level.
- p. Increase the audio source output level by 15 dB. Adjust A4R140 for 0-dB reading on front panel meter, using the +3 DBM full-scale markings.

##### 4.6.2 Transmit Audio Meter Adjustments (Transmit Audio A3)

**Note**

The variable resistors for these adjustments are accessible by extending transmit audio A3 (A2-B2).

- a. Perform line audio adjustments according to paragraphs 4.1.3 and 4.1.4.
- b. Set METER switch to CH A2 AF (+3FS) position. Set CHANNEL ENABLE A2 switch to LINE.
- c. Connect an audio source between TB1-1 and TB1-2 (XMT AF 600 $\Omega$ -A2).
- d. Set audio source to nominal frequency and nominal audio level for the application in which the exciter is being used.
- e. Set KEY switch to LOCK.
- f. Connect an audio voltmeter to A3TP3; note the audio voltmeter level; it should be 30  $\pm$ 0.5 mV rms.
- g. Adjust audio source output level downward until there is a sharp drop in the audio voltmeter reading. Slowly increase the audio source output level until the audio voltmeter reading just flattens out. Note the audio source output level.
- h. Increase the audio source output level by 15 dB. Adjust A3R88 for 0-dB reading front panel meter, using the +3 DBM full-scale markings.
- i. Set KEY switch to NORM.
- j. Set METER switch to CH B2 AF (+3FS) position and CHANNEL ENABLE B2 to LINE.
- k. Connect an audio source between TB1-3 and TB1-4 (XMT AF 600 $\Omega$ -B2).
- l. Set audio source to nominal frequency and nominal audio level for the application in which the exciter is being used.
- m. Set KEY switch to LOCK.

- n. Connect an audio voltmeter to A3TP5; note the audio voltmeter level; it should be  $30 \pm 0.5$  mV rms.
- o. Adjust audio source output level downward until there is a sharp drop in the audio voltmeter reading. Slowly increase the audio source output level until the audio voltmeter reading just flattens out; note the audio source output level.
- p. Increase the audio source output level by 15 dB. Adjust A3R140 for 0-dB reading on front panel meter, using the +3 DBM full-scale markings.

#### 4.6.3 Transmit Output Meter Adjustment (RF Translator A9)

**Note**

The variable resistor for this adjustment is accessible only by extending rf translator A9 and removing the shield that covers dc control board A9A8 (P/O A9). This adjustment is made with the transmit rf output set for +23 dB mW.

- a. Connect rf voltmeter (with 50- $\Omega$  load) to XMT OUT J22 on the rear panel. Set CHANNEL ENABLE A1 to LINE and MODE switch to ISB.
- b. Connect audio oscillator output between CH A1 XMT AF 600- $\Omega$  inputs (TB2-1, -2). Set KEY switch to LOCK and adjust audio oscillator for +23 dB mW on rf voltmeter.
- c. Set METER switch to XMT OUT (+23FS) position.
- d. Adjust A9A8R85 for +23-dB mW (full-scale) reading on the front panel meter.
- e. Set KEY switch to NORM and return exciter to operational assembly.

### 5. DISASSEMBLY/ASSEMBLY

**Warning**

Do not attempt disassembly or assembly of the unit with primary power applied.

**Caution**

This equipment contains electrostatic discharge sensitive (ESDS) devices. Special handling methods and materials must be utilized to prevent equipment damage. Refer to paragraph 7.4 Electrostatic Discharge Sensitive Devices Precautions, before performing maintenance on this equipment.

### 5.1 Disassembly

After removing the top and bottom cover plates of the exciter, the circuit cards all plug directly into connectors mounted on the chassis. Power supply A1, located at the rear of the unit, is secured to the chassis by screws. Subassemblies located behind the front panel are made accessible by removing the front panel. Subassemblies other than the plug-in circuit cards are interconnected by connectors mounted on ribbon-type cables.

**Note**

Retain hardware removed during disassembly for use in reassembly. Refer to unit parts list as an aid in disassembly and assembly.

#### 5.1.1 Meter Lamp Replacement

- a. Grasp spring-loaded white terminal block and pull block away from back of meter until lamps are clear. Rotate block 90 degrees and gently release.
- b. Remove and replace meter lamps.
- c. Grasp spring-loaded white terminal block and carefully rotate the block back to its original position.

#### 5.1.2 LED Status Display A2A1 Removal

- a. Remove unit top cover.
- b. Remove front panel from unit by removing four hexhead screws and attaching hardware.
- c. Remove four Phillips-head screws that secure LED status display A2A1 to hex screw posts/front panel.
- d. Disconnect plug P5 from LED status display jack A2J3.
- e. Carefully pull LED status display A2A1 from front panel mounted position (pull straight back).

#### 5.1.3 Switch Mounting Board A2A2 Removal

- a. Remove unit top cover.
- b. Remove front panel from unit by removing four hexhead screws and attaching hardware.

**Caution**

Upper overlay panel (plexiglass) is brittle; exercise care during removal of upper overlay panel.

- c. Remove upper overlay panel from front panel by:
  - 1. Removing four Phillips-head screws and lockwashers that secure back of front panel to upper edge bar.
  - 2. Removing four Phillips-head screws and lockwashers that secure back of front panel to panel support (middle bar on front panel).
  - 3. Lifting upper edge bar from front panel.
  - 4. Carefully removing upper overlay panel.
- d. Remove lower overlay panel from front panel by:
  - 1. Removing all knobs from front panel switches and controls.
  - 2. Removing four Phillips-head screws and lockwashers that secure back of front panel to lower edge bar.
  - 3. Lifting lower edge bar from front panel.
  - 4. Removing lower overlay panel.
- e. Remove attaching hardware from all switches, controls, and connectors on front panel.
- f. Disconnect plugs P3 and P4 from switch mounting board A2A2 jacks A2J2 and A2J1, respectively.
- g. Remove switch mounting board A2A2 by removing three Phillips-head screws and attaching hardware (screwheads on front of front panel). Be careful not to damage wiring of wire mounted controls and connectors.

#### **5.1.4 Frequency Display A2A5 Removal**

- a. Remove unit top cover.
- b. Remove four Phillips-head screws and attaching hardware.
- d. Disconnect plug P8 from jack A2J5 on frequency display A2A5.
- d. Carefully pull frequency display A2A5 from front panel mounted position.

#### **5.1.5 Frequency Switchboard A2A3 Removal**

- a. Remove unit top cover.
- b. Remove front panel from unit by removing four hexhead screws and attaching hardware.

#### **Caution**

Upper overlay panel (plexiglass) is brittle; exercise care during removal of upper overlay panel.

- c. Remove upper overlay panel from front panel by:
  - 1. Removing four Phillips-head screws and lockwashers that secure back of front panel to upper edge bar.
  - 2. Removing four Phillips-head screws and lockwashers that secure back of front panel to panel support (middle bar on front panel).
  - 3. Lifting upper edge bar from front panel.

- 4. Carefully removing upper overlay panel.
- d. Remove cover plate on back of front panel by removing five Phillips-head screws and attaching hardware (screwheads on front of front panel).
- e. Disconnect plug P2 from frequency switchboard A2A3 jack A2J4.
- f. Remove frequency switchboard A2A3 by removing four Phillips-head screws and attaching hardware (screwheads on front of front panel).

#### **5.2 Assembly**

Except for the subassemblies required to be mounted to the rear of the front panel before the panel is attached to the chassis, assembly of the unit is not in any certain order. The plug-in circuit cards are keyed so that each card can be inserted in only the correct connector.

##### **5.2.1 Frequency Switchboard A2A3 Installation**

- a. Install frequency switchboard A2A3 in front panel using four Phillips-head screws (screwheads on front of front panel).
- b. Install cover plate to back of front panel using five Phillips-head screws and attaching hardware (screwheads on front of front panel).
- c. Mount panel support (middle bar on front panel) to front panel by using four Phillips-head screws and lockwashers.

#### **Caution**

Upper overlay panel (plexiglass) is brittle; exercise care when installing upper overlay panel.

- d. Carefully install upper overlay panel into slot of middle bar on front panel.
- e. Carefully install upper edge bar and secure to front panel by using four Phillips-head screws and lockwashers.
- f. Plug P2 into frequency switchboard A2A3 jack A2J4.
- g. Install front panel to unit using four hexhead screws and attaching hardware.
- h. Install unit top cover.

##### **5.2.2 Frequency Display A2A5 Installation**

- a. Carefully slide frequency display A2A5 in place in front panel.
- b. Connect plug P8 to jack A2J5 on frequency display A2A5.
- c. Secure frequency display A2A5 using four Phillips-head screws and attaching hardware.
- d. Install unit top cover.

### 5.2.3 Switch Mounting Board A2A2 Installation

- a. Carefully install switch mounting board A2A2 to front panel using three Phillips-head screws and attaching hardware (screwheads on front of front panel). Be careful not to damage wiring of wire-mounted controls and connectors.
- b. Install the necessary attaching hardware on all front panel switches, controls, and connectors.
- c. Mount panel support (middle bar on front panel) to front panel by using four Phillips-head screws and lockwashers.
- d. Install lower overlay panel and speaker overlay panel into slot of middle bar on front panel.
- e. Carefully install lower edge bar and secure to front panel by using four Phillips-head screws and lockwashers.

**Caution**

Upper overlay panel (plexiglass) is brittle; exercise care when installing upper overlay panel.

- f. Carefully install upper overlay panel into slot of middle bar on front panel.
- g. Carefully install upper edge bar and secure to front panel by using four Phillips-head screws and lockwashers.
- h. Install all knobs on front panel switches and controls.
- i. Plug P3 and P4 into switch mounting board A2A2 jacks A2J2 and A2J1, respectively.
- j. Install front panel to unit using four hexhead screws and attaching hardware.
- k. Install unit top cover.

### 5.2.4 LED Status Display A2A1 Installation

**Caution**

LED status display A2A1 must be positioned correctly and pushed straight into front panel slot.

- a. Carefully push LED status display A2A1 into front panel mounted position.
- b. Secure LED status display A2A1 to hexscrew posts/front panel using four Phillips-head screws.
- c. Plug P5 into LED status display A2A1 jack A2J3.
- d. Install front panel to unit using four hexhead screws and attaching hardware.
- e. Install unit top cover.

## 6. REPAIR

Repair of the HF-8014( ) Exciter consists of replacing subassemblies and chassis-mounted components. For replacement of subassemblies, refer to paragraph 5. Use standard shop practices to replace chassis-mounted components.

## 7. CIRCUIT CARD REPAIR

### 7.1 General

**Caution**

This equipment contains electrostatic discharge sensitive (ESDS) devices. Special handling methods and materials must be utilized to prevent equipment damage. Refer to paragraph 7.4 Electrostatic Discharge Sensitive Devices Precautions, before performing maintenance on this equipment.

The following paragraphs provide information for repair and replacement of components mounted on subassemblies or circuit cards. Testing and troubleshooting procedures for circuit cards and subassemblies are included in the individual instruction sections in this instruction book. The following is a list of tools and materials necessary for repair of circuit cards:

- a. Flux, Kester 1544 or equivalent
- b. Solder, 0.5 mm (0.020 in) diameter, 63/37 rosin flux core or equivalent
- c. Solvent, Freon TMC
- d. Soldering iron, 40-watt, 1.588-mm (1/16 in) tip
- e. Solder sucker, plunger type
- f. Needle-nose pliers
- g. Small brush
- h. Pipe cleaners
- i. Diagonal cutters

### 7.2 Replacement of Resistors, Diodes, and Capacitors

#### 7.2.1 Removal

**Note**

Before removing diodes or polarized capacitors, note polarity marking and orientation on the circuit card.

**Caution**

Do not apply heat at a thru hole for more than 8 seconds.

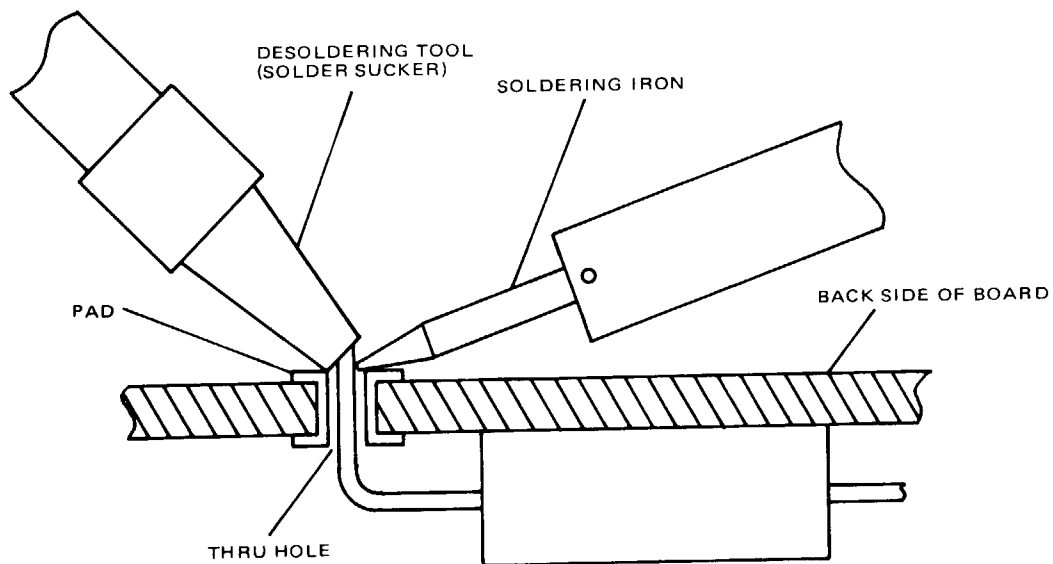

TP5-1226-019

*2-Lead Component Removal Diagram  
Figure 5*

- a. On back side of board (side opposite components), place soldering iron on pad of component to be removed until solder begins to melt. (Refer to figure 5.)
- b. Use a solder sucker and remove solder from hole. More solder may be required to conduct heat into hole and provide better suction for removal.
- c. Use needle-nose pliers to remove lead from hole. It may be necessary to reheat lead, as a certain amount of solder will remain in thru hole.
- d. When component has been removed, reheat thru holes, and, using a solder sucker, remove excess solder. Reheat procedure, as necessary, until holes are clean, as indicated by lack of solder on walls, top, or bottom.

**7.2.2 Installation**

- a. Using a small brush or tip of a pipe cleaner dipped in solvent, carefully clean both sides of surface area, thru holes, and pads.
- b. Observe polarity markings and properly orient component. Shape leads of the replacement component so that leads fit freely into correct thru holes.
- c. Gently maneuver component, inserting leads into proper thru holes, until component is inserted to

proper depth or until body of component makes contact with surface of circuit board.

**Note**

Do not crimp or bend leads to hold component in position for soldering. Protruding portion of lead should remain straight to prevent damage to circuit board if subsequent replacement is required.

- d. Using small diagonal cutters, cut leads so that protruding length (approx 1.5 mm (1/16 in)) matches that of other components.
- e. Using flux and solder sparingly, solder each lead on side opposite component. Ensure that component does not shift position during soldering procedure.
- f. Carefully inspect all new solder joints for evidence of poor connection, cold solder, or short circuit. Solder should completely fill thru hole without excess. (Refer to figure 6.)
- g. Using a small brush or the tip of a pipe cleaner dipped in solvent, thoroughly clean all new soldered joints. Ensure that all flux and rosin are removed. Solder joints should appear clean, smooth, and bright.



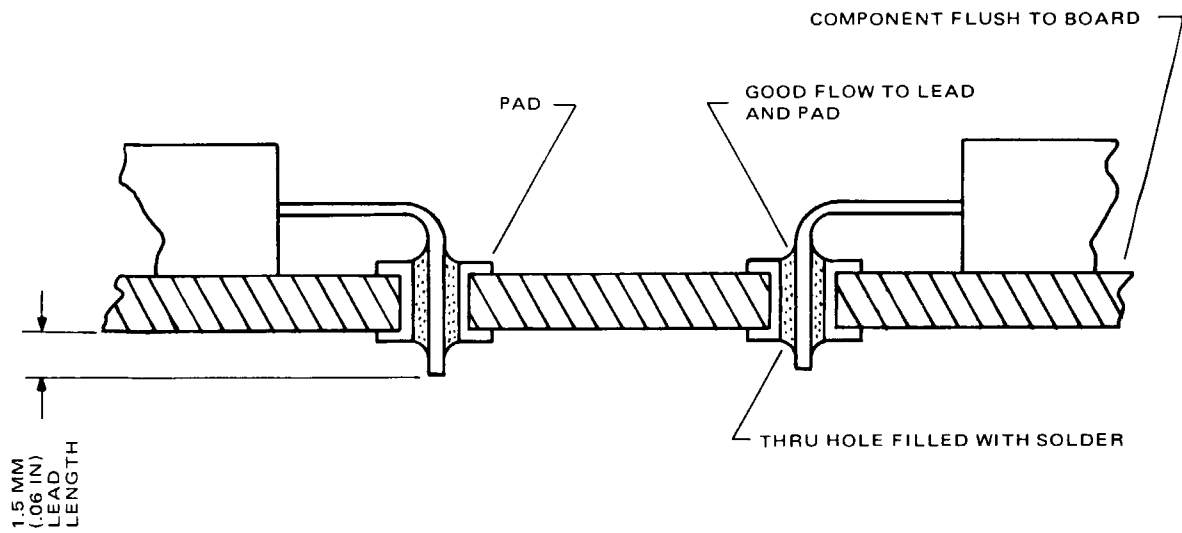

TP5-1227 019

2-Lead Component Installation Diagram  
Figure 6

### 7.3 Replacement of Multilead Components (Transistors, Transformers, Dual-in-Line Packages, Relays, Etc)

#### 7.3.1 Removal

- Locate component to be removed. Note position, lead conformation, and physical alignment of component. Observe position of orientation tab, if any. Determine pads and thru holes used for mounting.
- Lay circuit board flat on a clean surface with component side facing down.

**Caution**

Do not apply heat at a pad or thru hole for longer than 8 seconds.

- Place soldering iron tip to one pad and lead until solder begins to melt. Use a solder sucker to remove excess solder. More solder may be required to conduct heat into hole and to provide better suction for solder removal. (Refer to figure 7.)
- Allow circuit board to cool before applying heat to thru hole in same area. Repeat procedure for each lead.
- When all leads have been unsoldered, remove component from board.

- When component has been removed, reheat each hole. When solder is melted, use a solder sucker to remove excess solder. Allow circuit board to cool before reapplying heat in same area. Repeat procedure, as required, until each thru hole is clean, as indicated by absence of solder on walls, top, and bottom.

#### 7.3.2 Installation

- Using a small brush or tip of a pipe cleaner dipped in solvent, carefully clean both sides of circuit board in mounting area. Clean mounting holes and pads.
- Carefully bend leads of new component to same configuration as old one so that leads fit freely into correct thru holes. Do not cut leads at this time.
- Gently maneuver component, inserting leads into proper thru holes. Continue with rocking movement until component is inserted to proper depth.

**Note**

Do not crimp or bend leads to hold component in position for soldering. The protruding portion of lead should remain straight to prevent damage to circuit board if subsequent replacement is required.

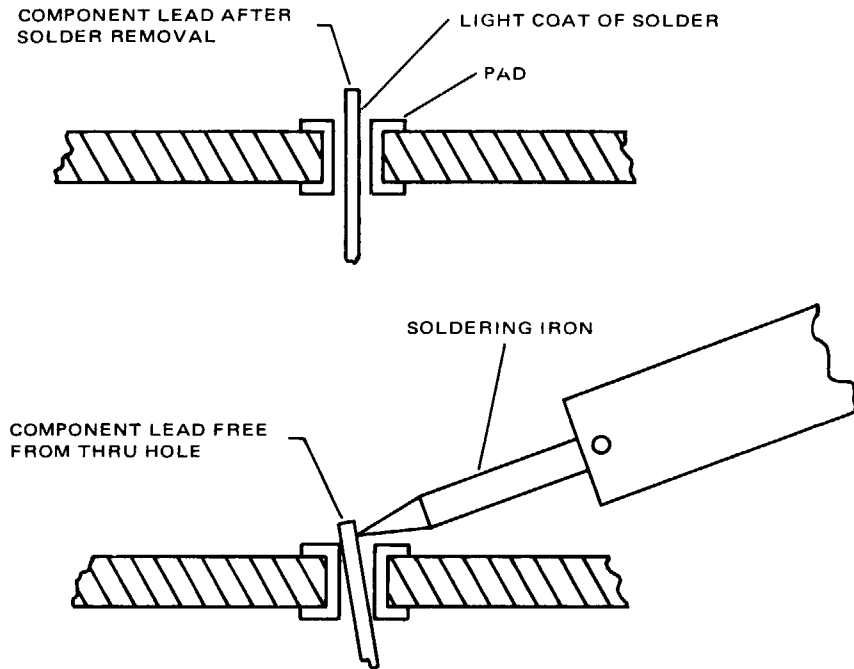

TP2-4252-012

*Multilead Component Removal Diagram  
Figure 7*

- d. Using small diagonal cutters, cut leads so that protruding length (approx 1.5 mm (1/16 in)) matches that of other components.

**Caution**

Do not apply heat at a thru hole for longer than 8 seconds.

- e. Using flux and solder sparingly, solder each lead at side opposite component. Ensure that component does not shift position during soldering procedure.
- f. Allow circuit board to cool before applying heat to other thru holes.
- g. Carefully inspect all new solder joints for evidence of poor connections, cold or excess solder, or short circuits. Solder should completely fill hole without excess. (Refer to figure 8.)
- h. Using a small brush or tip of pipe cleaner dipped in solvent, thoroughly clean all new soldered joints. Ensure that all flux is removed. Solder joints should appear clean, smooth, and bright.

**7.4 Electrostatic Discharge Sensitive Devices  
Precautions**

A static charge is produced by friction between, and separation of, dissimilar materials. Potentials of 1 to 20 kilovolts are commonly generated on the human body or insulated surfaces. Voltages of this magnitude can produce both immediate and latent failure in ESDS devices. Highly sensitive (0 to 400 V) ESDS devices include metal-oxide-semiconductor (MOS) without input protection (C-MOS, D-MOS, N-MOS, P-MOS, V-MOS, etc) and surface acoustic wave (SAW). Most other solid state electronic devices are ESDS and fall in the moderately sensitive (400 to 2500 volts) or marginally sensitive (2500 to 15 000 V) range.

**Note**

Dry weather (relative humidity less than 30 percent) multiplies the accumulation of static charges on a surface. In a low-humidity environment, the handling procedures specified are of greater importance and should be adhered to without exception.

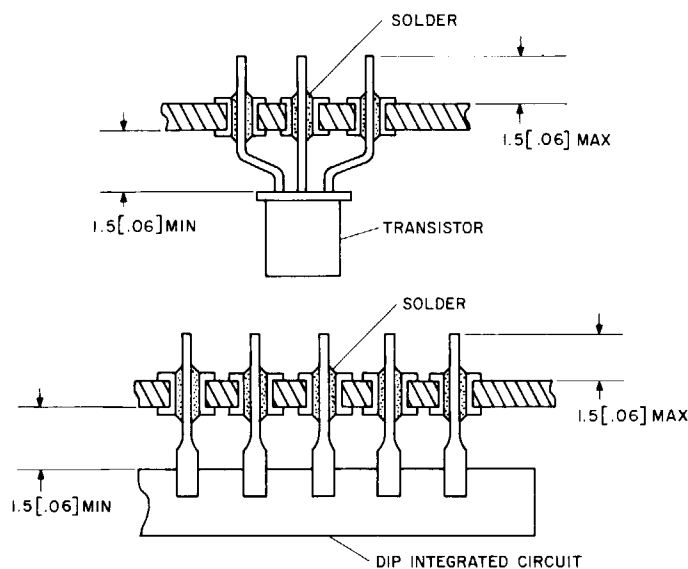

NOTE:  
1. UNLESS OTHERWISE SPECIFIED, DIMENSIONS ARE IN MILLIMETRES [INCHES].

TP5-0981-013

*Multilead Component Installation Diagram  
Figure 8*

#### 7.4.1 Handling of ESDS Devices

**Caution**

Nylon or synthetic gloves should not be used when handling ESDS devices. Excessive static can build up on this type of material. Handle ESDS devices by their case whenever possible. Avoid touching the leads on contacts even though grounded.

The transport of ESDS devices at the component level requires that all device leads be effectively shorted together. This can be accomplished by one of the following methods:

- a. Insert device in high density conductive foam.
- b. Insert device in aluminum foil-lined individual packages.
- c. Insert device in a dual-in-line carrier tube made of aluminum or specially coated plastic. (Must be labeled as static charge dissipative.)

The label shown below shall be shown on all individual part containers:

**Caution**

This component can be damaged by static electricity. Special handling methods and materials must be utilized.

Antistatic protection is required for ESDS devices from the time they are received until they are terminated in a protective subassembly. If ESDS devices are in subassemblies that do not provide adequate ESDS device protection, they are still vulnerable to static damage.

Transport of circuit board or module subassemblies containing ESDS devices requires that contact with exposed subassemblies be prevented. Conductive plastic bags, not clear polyvinyl, are well suited to this purpose. Plastic bags should be adequate in size to enclose the subassembly being transported. After

the subassembly, containing ESDS devices, is installed in the top level unit, normal ESDS devices handling is adequate.

#### **7.4.2 Storage of ESDS Devices**

Methods of handling, described in paragraph 7.4.1, are appropriate for storage.

#### **Caution**

Lead corrosion may result if the device or assembly is stored in a high temperature/high humidity environment.

#### **7.4.3 Testing of Subassemblies Containing ESDS Devices**

Observe the following precautions when testing any subassembly containing ESDS devices:

- a. Remove power from test fixtures or equipment before inserting/removing any ESDS device or subassembly containing an ESDS device.
- b. All test equipment must be well-grounded.
- c. Apply dc source power to ESDS device or subassembly containing an ESDS device before applying any signal voltages.
- d. Remove signal voltages from ESDS device or subassembly containing an ESDS device before removing dc source power.
- e. Dielectric strength or insulation resistance checks are not recommended for any ESDS device or subassembly containing an ESDS device.

#### **7.4.4 Replacement of ESDS Devices**

Protective carriers for ESDS devices should be placed on grounded conductive work station surfaces. This

permits the dissipation of any static charge prior to removal, transfer, or insertion of any ESDS device into a subassembly.

It is recommended that an ionized air blower be used in the work area where personnel are handling ESDS devices, and that personnel work in the path of the ionized air. The blower should be operated for 3 minutes before handling an ESDS device so that residual static charges may be removed. In lieu of an ionized air blower, a grounded wrist strap in contact with bare skin can be used.

#### **Warning**

If a grounded wrist strap is used, make sure that no voltages exist in the area of the work station.

Observe the following precautions when replacing an ESDS device:

- a. Soldering iron tips, special tools, and hand tools should be well-grounded.
- b. Only uninsulated metal hand tools should be used. All hand tools shall be placed on the conductive work station surface when not in use.
- c. The leads of the ESDS devices should be in contact with a conductive material, except when being installed, to avoid buildup of static charge.
- d. ESDS devices should not be installed (inserted) in, or removed from, circuits with the power on because transient voltages may cause damage.
- e. All unused input leads of the ESDS device must be connected to ground or the ESDS device supply, whichever is applicable for the logic circuit involved.



Rockwell  
International

**parts list**

**HF-8014( )  
Exciter**

Collins Telecommunications Products Division

523-0770726-001218

1 January 1981

Printed in USA

**list of illustrations**

<i>Figure</i>		<i>Page</i>
1	HF-8014( ) Exciter .....	4
2	Front Panel A2 .....	11
3	Mounting Board A2A2 .....	15
4	Synthesizer Chassis A27 .....	17
5	Synthesizer Sideboard (P/O A27) .....	19
6	RFI Filter A24 .....	22

Parts List

HF-8014( ) Exciter

523-0770726-001218



# parts list

## 1. INTRODUCTION

### 1.1 General

The purpose of this parts list, prepared by Collins Telecommunications Products Division of Rockwell International, is for identification, requisition, and issuance of parts.

Parts listed meet critical equipment design specification requirements. Use only part numbers specified in this parts list for replacement of parts.

### 1.2 Group Assembly Parts List

FIG-ITEM Column — Digits preceding the dash refer to figure numbers. Digits following the dash are item numbers assigned in sequence to correspond with item numbers on the illustrations.

PART NO Column — Listed are MIL standard, vendor, or Collins part numbers. Collins part numbering system consists of 10 digits as follows: a 3-digit family number, a 4-digit serial number, and a 3-digit dash number.

INDENT Column — Items are coded 1, 2, 3, etc, to indicate the relationship to the next higher assembly.

DESCRIPTION Column — Lists the noun name, modifier, descriptive information, federal manufacturer's code, reference designation, attaching part (AP), reference to other figures, and effectivities.

Attaching parts are identified by (AP) following the part or parts they attach.

Effectivities are identified by the following methods: MCN (Manufacturer Control Number) 101 and up; CI (Configuration Identifier) 5-digit number; REV (Revision Identifier) dash (—) denotes original, letter A first change, letter B second change, etc. One of the above identifiers is listed on each chassis and/or replaceable assembly. Service Bulletins are identified by SB 1, SB 2, etc.

UNITS PER ASSY Column — Quantities specified are per item number. Letters AR denote the selection of parts as required. Letters REF refer to an assembly completely assembled on a preceding figure and illustration.

USABLE ON CODE Column — Part variations within a group of equipment are indicated by a letter code (A, B, C, etc). Absence of a code indicates part applies to all models.

#### **Caution**

This equipment contains electrostatic discharge sensitive devices, indicated in the description column by (ESDS). Special handling methods and materials must be used to prevent equipment damage. Refer to the maintenance section before assembly/disassembly or repair is performed. All illustrations that contain ESDS devices have the following symbol attached.



### 1.3 Numerical Index

PART NUMBER Column — Part numbers are listed in alphanumeric sequence.

FIG-ITEM Column — Digits preceding the dash refer to figure numbers. Digits following the dash are item numbers.

TTL REQ Column — Listed is the total quantity of parts or assemblies covered in the Group Assembly Parts List.

### 1.4 Reference Designation Index

REFERENCE DESIGNATION Column — Reference designations are listed in alphanumeric sequence.

parts list 523-0770726

FIG-ITEM Column — Digits preceding the dash refer to figure numbers. Digits following the dash are item numbers.

PART NUMBER Column — Part numbers listed are for items that have reference designations assigned.

**1.5 How To Use This Parts List**

To locate a part number if the assembly in which the part is used is known, turn to the List of Illustrations and find the page number for the assembly in which the part is used. Locate the part and its index number on the illustration and find the index number on the Group Assembly Parts List page to determine its description and part number.

To locate the illustration for a part if the part number is known, refer to the Numerical Index and find the part number. Turn to the Group Assembly Parts List and find the first figure and index number indicated in the Numerical Index for that part. If this figure shows the part in a section or system of the equipment other than the one desired, refer to the other figure numbers listed in the Numerical Index.

To locate the illustration for a part if the reference designation is known, refer to the Reference Designation Index and find the symbol; turn to the Group Assembly Parts List and find the figure and index number indicated in the index.

**1.6 Manufacturer's Code, Name, and Address.**

<u>CODE</u>	<u>MANUFACTURER'S NAME AND ADDRESS</u>
00779	AMP INC P O BOX 3608 HARRISBURG PA 17105
03508	GENERAL ELECTRIC CO SEMI-CONDUCTOR PRODUCTS DEPT W GENESEE ST AUBURN NY 13021
05574	VIKING INDUSTRIES INC DATACON DIV 21001 NORDHOFF ST CHATSWORTH CA 91311
08664	ACCO INDUSTRIES INC BRISTOL DIV 40 BRISTOL ST WATERBURY CT 06720
09353	C AND K COMPONENTS INC 103 MORSE STREET WATERTOWN MA 02172
12294	ERIE TECHNOLOGICAL PRODUCTS OF CANADA LTD 5 FRASER AVE TRENTON ONTARIO CAN K8V 5S1
12998	QUALITY NAME PLATE INC MILL ROAD EAST GLASTONBURY CT 06025
13499	ROCKWELL INTERNATIONAL CORP COLLINS TELECOMMUNICATIONS PRODUCTS DIV PO BOX 728 855 35TH STREET NE CEDAR RAPIDS IA 52406
18677	SCANBE MFG CO 3445 FLETCHER AVE EL MONTE CA 91731
23730	MARK EYELET AND STAMPING INC 63 WAKELEE RD WOLCOTT CT 06716
27478	HARBOUR INDUSTRIES INC WIRE DIVISION P O BOX 188 SHELBURNE VT 05482
28520	HEYMAN MANUFACTURING CO 147 MICHIGAN AVE KENILWORTH NJ 07033
31918	ITT SCHADOW INC 8081 WALLACE RD EDEN PRAIRIE MN 55343
34785	DEK INC 1555 HAWTHORNE LN W CHICAGO IL 60185
56289	SPRAGUE ELECTRIC CO NORTH ADAMS MA 01247
65092	WESTON INSTRUMENTS DIV SANGAMO WESTON INC 614 FRELINGHUYSEN AVE NEWARK NJ 07114
70903	BELDEN CORP 2000 S BATAVIA AVE GENEVA IL 60134
71124	BRAND-REX CO RT 32 P O BOX 498 WILLIMANTIC CT 06226
71400	BUSSMANN MFG DIV MCGRAW-EDISON CO 502 EARTH CITY PLAZA P O BOX 14460 ST LOUIS MO 63178
71468	ITT CANNON ELECTRIC DIV INTERNATIONAL TELEPHONE AND TELEGRAPH CO 666 E DYER RD SANTA ANA CA 92702
71590	GLOBE-UNION INC CENTRALAB ELECTRONICS DIV HWY 20 W P O BOX 858 FORT DODGE IA 50501
71785	TRW CINCH CONNECTORS 1501 MORSE AVE ELK GROVE VILLAGE IL 60007



MANUFACTURER'S NAME AND ADDRESS

<u>CODE</u>	<u>MANUFACTURER'S NAME AND ADDRESS</u>
72606	GASKET MFG CO 18001 S MAIN ST GARDENA CA 90248
74970	JOHNSON E F CO 299 10TH AVE S W WASECA MN 56093
76854	OAK INDUSTRIES INC SWITCH DIV 100 S MAIN ST CRYSTAL LAKE IL 60014
77147	PATTON-MACGUYER CO DIV OF AVID CORP 17 VIRGINIA AVE PROVIDENCE RI 02905
77250	PHEOLL MFG CO DIV OF ALLIED PRODUCTS CCRP 5700 W ROOSEVELT RD CHICAGO IL 60650
77969	RUBBERCRAFT CORP OF CALIF LTD 1800 W 220TH ST TORRANCE CA 90507
79807	WROUGHT WASHER MFG INC 2100 S O BAY ST MILWAUKEE WI 53207
79963	ZIERICK MFG CO RADIO CIRCLE MT KISCO NY 10549
81349	MILITARY SPECIFICATION
86797	ROGAN CORP 3455 WOODHEAD DR NORTHBROOK IL 60062
91314	LEWIS SPRING AND MFG CO 2652 W NORTH AVE CHICAGO IL 60647
93790	CORNELL-DUBILIER ELECTRONICS DIV FEDERAL PACIFIC ELECTRIC CO 1605 RODNEY FRENCH BLVD NEW BEDFORD MA 02741
94375	AUTOMATIC CONNECTOR INC 400 MORELAND RD COMMACK NY 11725
96906	MILITARY STANDARD
98291	SEAELECTRO CORP 225 HOYT MAMARONECK NY 10544

**1.7 Usable on Codes**

The following usable on codes have been assigned in this manual:

<u>USABLE ON CODES</u>	<u>UNIT PART NUMBER</u>	<u>FIG-ITEM</u>
A	622-3472-001	1-
B	622-3473-001	1-
C	622-3473-002	1-
D	622-3473-003	1-
E	622-3473-004	1-

**1.8 Reference Designation Prefixes**

The following prefixes have been assigned in this manual:

<u>PREFIX</u>	<u>UNIT PART NUMBER</u>	<u>FIG-ITEM</u>
A1	635-9649-001	1-26
A2	634-8199-001	2-
A2	634-8199-002	2-
A2A1	635-0825-012	2-50
A2A2	638-6597-001	3-
A2A3	635-0830-001	2-48
A2A5	637-1781-006	2-36
A3	638-6476-003	1-106
A4	638-6476-001	1-105
A5	638-6636-003	1-110
A6	638-6636-002	1-111
A7	638-6636-001	1-112
A8	638-6659-001	1-113
A9	637-1768-002	1-114
A10	638-6622-001	1-119
A11	642-3135-001	1-118
A12	642-3137-001	1-117
A13	638-6896-001	1-116
A14	635-0656-001	1-118
A15	638-6962-001	1-119
A16	642-2451-001	1-120
A19	635-0657-001	1-121
A20	623-2080-003	1-122
A21	623-2080-002	1-123
A22	623-2080-001	1-124
A23	635-4930-001	1-125
A23	635-4930-002	1-125
A24	637-2712-001	6-
A25	634-8211-001	1-36
A27	634-8201-001	4-

**1.9 Configuration Identifiers**

The following CI's/REV LTR's were used in compiling data for this manual:

<u>CI/REV LTR</u>	<u>UNIT PART NUMBER</u>	<u>FIG-ITEM</u>
A	622-3472-001	1-
F	622-3473-001	1-
F	622-3473-002	1-
F	622-3473-003	1-
F	622-3473-004	1-
C	634-8199-001	2-
C	634-8199-002	2-
E	638-6597-001	3-
A	634-8201-001	4-
G	638-6973-001	5-
M	637-2712-001	6-

2. GROUP ASSEMBLY PARTS LIST

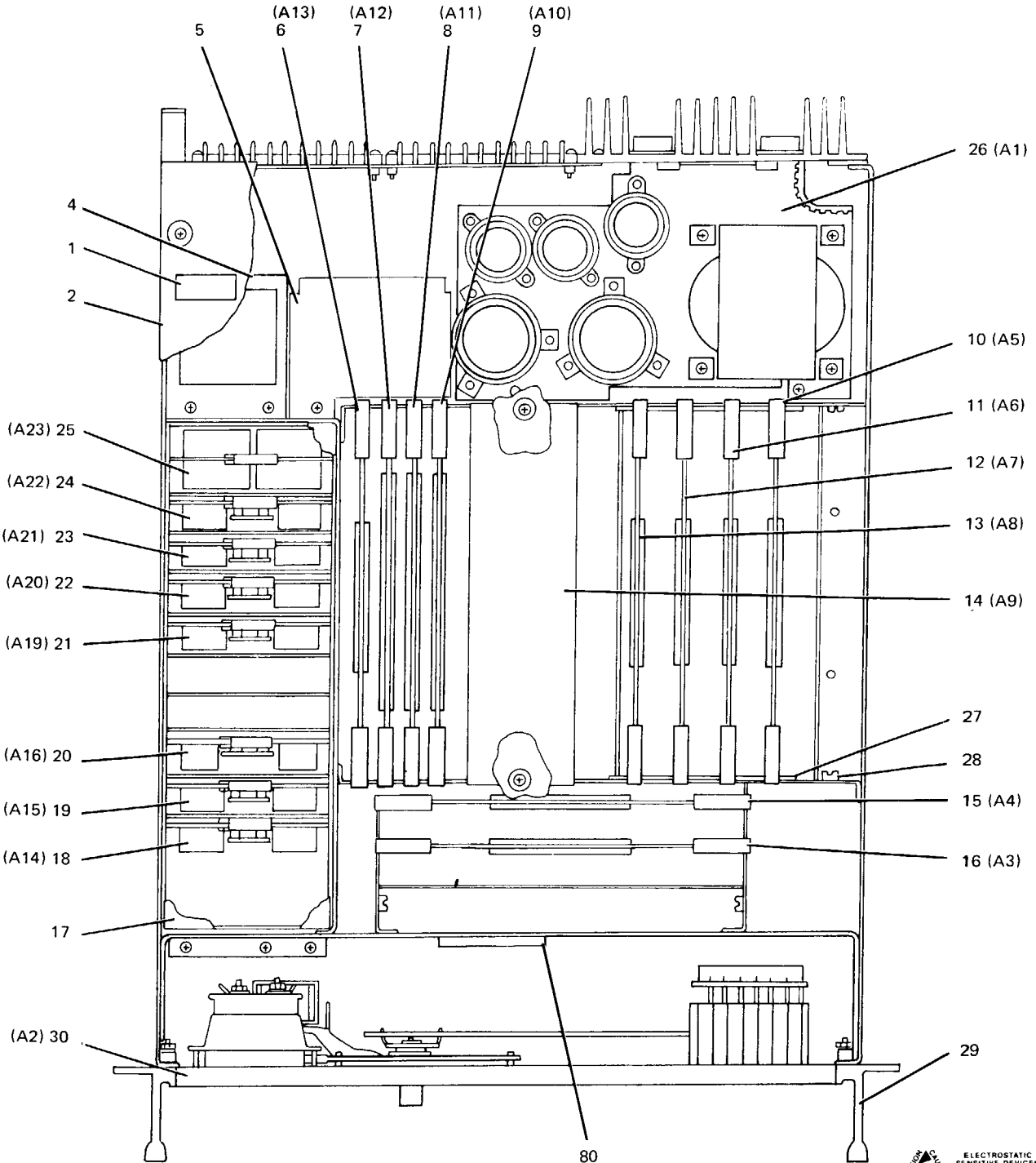

TOP VIEW

CAUTION  
ELECTROSTATIC SENSITIVE DEVICES  
OBSERVE PRECAUTIONS  
FOR HANDLING

TPA-2482-049

HF-8014 ( ) Exciter  
Figure 1 (Sheet 1 of 4)

GROUP ASSEMBLY PARTS LIST

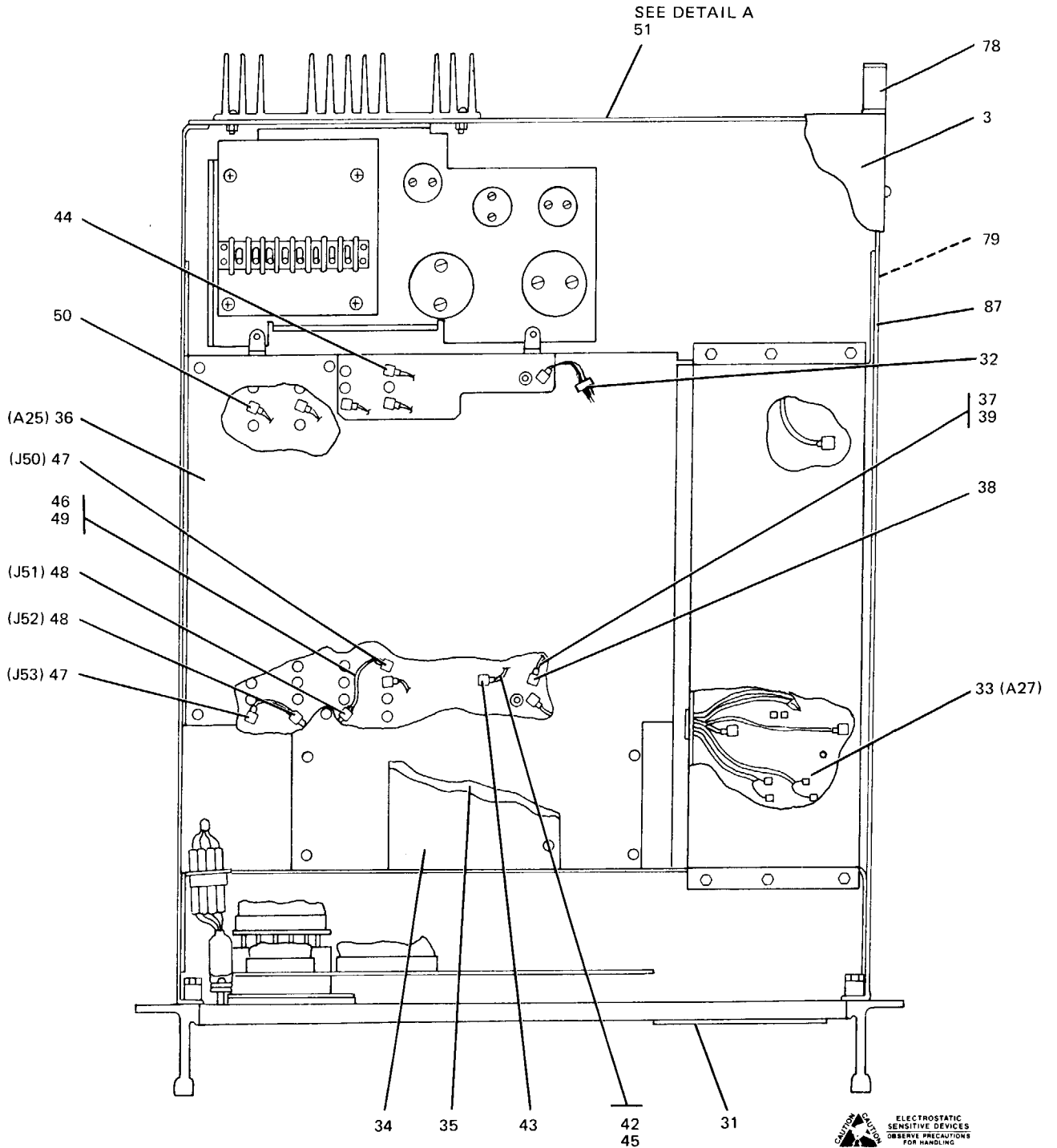

BOTTOM VIEW

CAUTION  
ELECTROSTATIC SENSITIVE DEVICES  
OBSERVE PRECAUTIONS FOR HANDLING

TPA-2482-049

HF-8014( ) Exciter  
Figure 1 (Sheet 2)

GROUP ASSEMBLY PARTS LIST

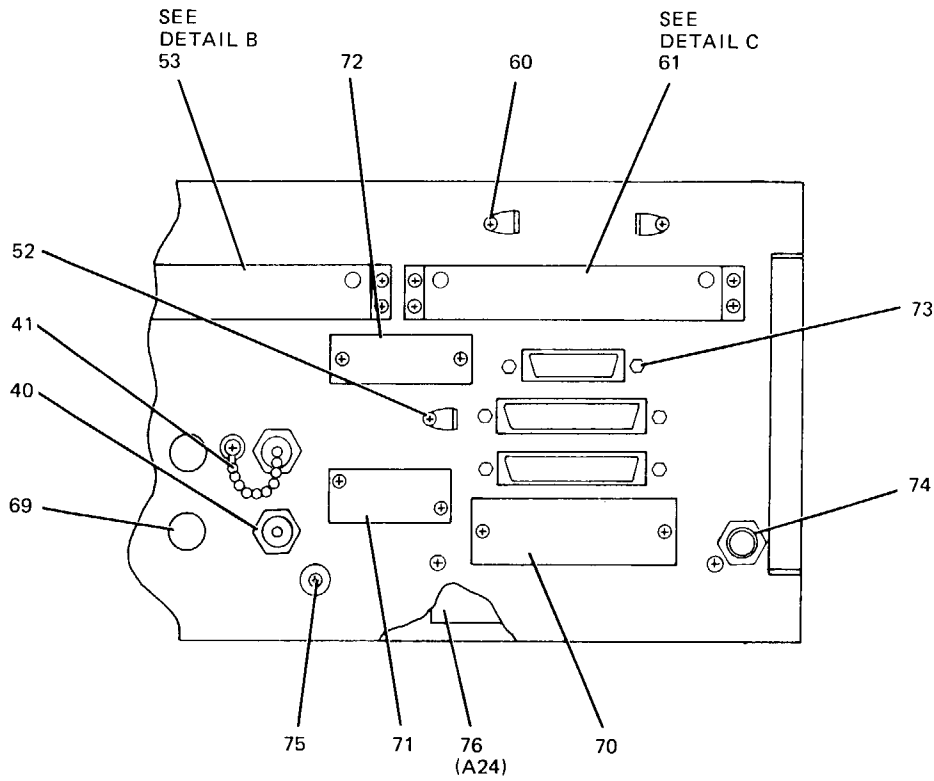

DETAIL A

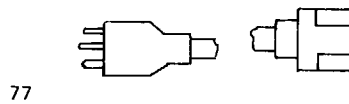

77

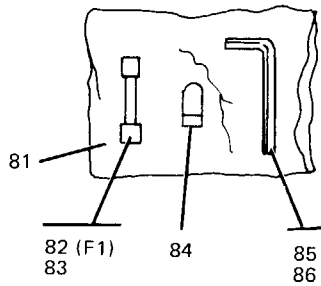

82 (F1)  
83

84

85  
86



TPA-2482-049

HF-8014( ) Exciter  
Figure 1 (Sheet 3)

GROUP ASSEMBLY PARTS LIST

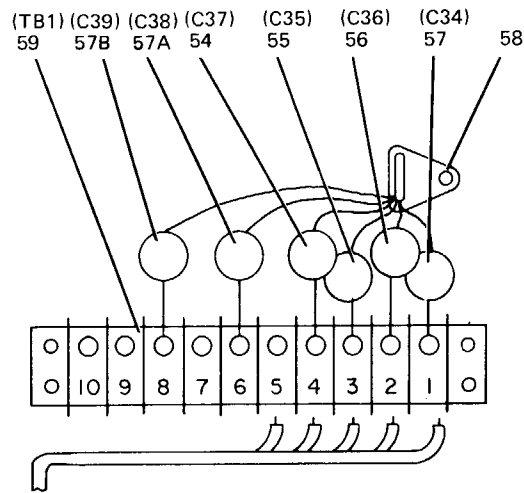

DETAIL B

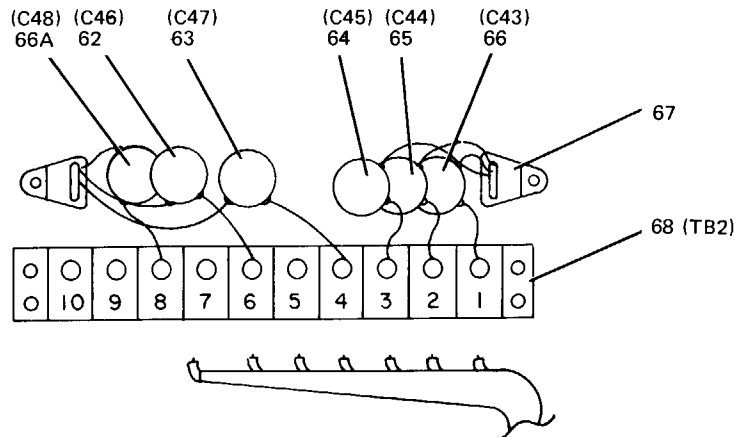

DETAIL C



TPA-2482-049

HF-8014( ) Exciter  
Figure 1 (Sheet 4)

GROUP ASSEMBLY PARTS LIST

FIG-ITEM	PART NO	INDENT	DESCRIPTION	UNITS PER ASSY	USABLE ON CODE
1-	622-3472-001	1	EXCITER, HF-8014 (ESDS)	1	A
	622-3473-001	1	EXCITER, HF-8014A (ESDS)	1	B
	622-3473-002	1	EXCITER, HF-8014A (ESDS)	1	C
	622-3473-003	1	EXCITER, HF-8014A (ESDS)	1	D
	622-3473-004	1	EXCITER, HF-8014A (ESDS)	1	E
1	280-1368-350	2	LABEL,PRESSURE (12998)	1	
2	634-8180-002	2	COVER, TOP	1	A
2	634-8181-002	2	COVER, TOP	1	B, C, D, E
3	634-8179-001	2	COVER, BOTTOM	1	
	MS51957-28	2	SCREW, MACH SST, 6-32 X 3/8 (96906) 343-0169-000 (AP FOR 2,3)	15	
	MS51957-30	2	SCREW, MACH SST, 6-32 X 1/2 (96906) 343-0171-000 (AP FOR 2)	2	
4	622-3460-001	2	KIT, OVEN STANDARD (AC-8012)	1	C, D, E
5	622-3499-001	2	KIT, FREQUENCY STANDARD SWITCH (AC-8015)	1	B, C, D, E
6	638-6896-001	2	SERIAL INTERFACE (ESDS) A13	1	B, C, D, E
7	642-3137-001	2	PARRELL OUTPUT (ESDS) A12	1	B, C, D, E
8	642-3135-001	2	PARRELL INPUT (ESDS) A11	1	B, C, D, E
9	638-6622-001	2	CONTROL (ESDS) A10	1	
10	638-6636-003	2	CHANNEL B2 IF (ESDS) A5	1	A, B, C
11	638-6636-002	2	CHANNEL A2 IF (ESDS) A6	1	A, B, C
12	638-6636-001	2	CHANNEL B1 IF (ESDS) A7	1	A, B, C, D
13	638-6659-001	2	CHANNEL A1 IF (ESDS) A8	1	
14	637-1768-002	2	RF TRANSLATOR A9	1	
15	638-6476-001	2	A1-B1 TRANSMIT AUDIO (ESDS) A4	1	
16	638-6476-003	2	A2-B2 TRANSMIT AUDIO (ESDS) A3	1	
17	642-2409-001	2	COVER, TOP-CARD RACK	1	
	MS51957-3	2	SCREW, MACH CD PL STL, 2-56 X 1/4 (96906) 343-0124-000 (AP)	5	
	MS35338-134	2	WASHER, LOCK SST, 0.088 ID X 0.172 OD (96906) 310-0275-000 (AP)	5	
18	635-0656-001	2	SYNTH VOLTAGE REGULATOR A14	1	
19	638-6962-001	2	SYNTHESIZER SUBCARRIER (ESDS) A15	1	A, B, C
20	642-2451-001	2	SYNTHESIZER REFERENCE A16	1	
21	635-0657-001	2	SYNTH END DECADE A19	1	
22	623-2080-003	2	SYNTH 1KHZ DECADE A20	1	
23	623-2080-002	2	SYNTH 10KHZ DECADE A21	1	
24	623-2080-001	2	SYNTH 100KHZ DECADE A22	1	
25	635-4930-001	2	SYNTHESIZER OUTPUT A23	1	A
25	635-4930-002	2	SYNTHESIZER OUTPUT A23	1	B, C, D, E
26	635-9649-001	2	POWER SUPPLY A1	1	
27	634-8176-001	2	SHEET, CARD GUIDE	2	
	MS35649-244	2	NUT, PLAIN, HEX SST, 4-40 (96906) 313-0043-000 (AP)	8	
	MS35338-135	2	WASHER, LOCK SST, 0.115 ID X 0.209 OD (96906) 310-0279-000 (AP)	8	
	MS51957-13	2	SCREW, MACH STL, 4-40 X 1/4 (96906) 343-0133-000 (AP)	26	A
	MS51957-13	2	SCREW, MACH STL, 4-40 X 1/4 (96906) 343-0133-000 (AP)	22	B, C, D, E
28	23071-4	2	CARD GUIDE, FC (18677) 150-0810-040	16	
29	635-9616-001	2	FLANGE, CHASSIS	2	
	541-6106-002	2	SPACER, SLV (AP)	4	
	MS35650-304	2	NUT, PLAIN, HEX SST, 10-32 (96906) 313-0019-000 (AP)	4	
	MS35338-138	2	WASHER, LOCK SST, 0.194 ID X 0.334 OD (96906) 310-0284-000 (AP)	4	
	P312-0116-000	2	STUD, CONT THD STL, 10-32 X 1 (77250) 312-0116-000 (AP)	4	
30	634-8199-001	2	PANEL, FRONT A2 (SEE FIG 2)	1	A, B
30	634-8199-002	2	PANEL, FRONT A2 (SEE FIG 2)	1	C, D, E
31	634-8191-001	2	INSERT, IDENT	1	A
31	634-8192-001	2	INSERT, IDENT	1	B, C, D, E
32	025-0250	2	CLAMP, CABLE (34785) 150-0873-010	8	
33	634-8201-001	2	CHASSIS, SYNTHESIZER A27 (SEE FIG 4)	1	
	P313-0045-000	2	NUT, PLAIN, HEX SST, 6-32 (77250) 313-0045-000 (AP)	6	
	310-0071-000	2	WASHER, LOCK SST, 0.151 ID X 0.239 OD (79807) (AP)	6	
	MS51957-28	2	SCREW, MACH SST, 6-32 X 3/8 (96906) 343-0169-000 (AP)	6	

## GROUP ASSEMBLY PARTS LIST

FIG-ITEM	PART NO	INDENT	DESCRIPTION	UNITS PER ASSY	USABLE ON CODE
1-34	642-2455-001	2	GUARD,CABLE	1	
35	630-2189-001	2	GUARD, CABLE	1	
	115-0260-003	2	SPACER (74970) 150-1012-030 (AP FOR 34,35)	4	
36	634-8211-001	2	ASSEMBLY, SIDEBOARD A25	1	
	MS51957-13	2	SCREW,MACH STL, 4-40 X 1/4 (96906) 343-0133-000 (AP)	16	
	MS35338-135	2	WASHER,LOCK SST, 0.115 ID X 0.209 OD (96906)	16	
			310-0279-000 (AP)		
	310-6340-000	2	WASHER,FLAT SST, 0.125 ID X 0.281 OD (79807) (AP)	8	
	540-9039-003	2	POST,ELEC-MECH (AP)	8	
37	637-1525-004	2	CABLE ASSY, RF COAXIAL	1	
38	52-312-9094	3	JACK,RA,BLKHD (98291) 357-7207-320	1	
39	RG178BU	3	CABLE,RF (81349) 425-1538-000	AR	
40	801-B3800B75	3	CONNECTOR,RCPT ELEC (94375) 357-7129-010 J22	1	
	MS35649-244	2	NUT,PLAIN,HEX SST, 4-40 (96906) 313-0043-000 (AP)	1 A	
	310-6340-000	2	WASHER,FLAT SST, 0.125 ID X 0.281 OD (79807) (AP)	1 A	
41	M39012-25-0006	2	COVER-CHAIN (81349) 357-9069-000	1 B,C,D,E	
	MS51957-29	2	SCREW,MACH SST, 6-32 X 7/16 (96906) 343-0170-000 (AP)	1 B,C,D,E	
	310-6340-000	2	WASHER,FLAT SST, 0.125 ID X 0.281 OD (79807) (AP)	1 B,C,D,E	
	310-0071-000	2	WASHER,LOCK SST, 0.151 ID X 0.239 OD (79807) (AP)	1 B,C,D,E	
	P313-0045-000	2	NUT,PLAIN,HEX SST, 6-32 (77250) 313-0045-000 (AP)	1 B,C,D,E	
42	637-1526-003	2	CABLE ASSY, RF COAXIAL	1	
43	52-312-9040	3	CONNECTOR,RCPT ELEC (98291) 357-7207-220	1	
44	52-312-9040	3	CONNECTOR,RCPT ELEC (98291) 357-7207-220	1	
45	RG178BU	3	CABLE,RF (81349) 425-1538-000	AR	
46	642-2454-001	2	CABLE ASSY	1	
	055-905-0069	2	FLOAT,CONNECTOR (98291) 357-8985-020 (AP)	2	
47	51-330-3188	3	CONNECTOR,RCPT ELEC (98291) 357-7374-010 J50 J53	2	
48	51-071-0019	3	CONNECTOR,TEE (98291) 357-7533-010 J51 J52	2	
49	12-954	3	CABLE,RF (27478) 425-0217-010	AR	
50	623-1379-001	2	BUSHING,COAX	14	
51	635-9611-003	2	PANEL,REAR	1	
	MS51957-29	2	SCREW,MACH SST, 6-32 X 7/16 (96906) 343-0170-000 (AP)	7	
	MS51958-61	2	SCREW,MACH SST, 10-32 X 3/8 (96906) 343-0226-000 (AP)	2	
52	403	2	TERMINAL,LUG (79963) 304-1089-000	1	
	MS35649-244	2	NUT,PLAIN,HEX SST, 4-40 (96906) 313-0043-000 (AP)	1	
	MS35338-135	2	WASHER,LOCK SST, 0.115 ID X 0.209 OD (96906)	1	
			310-0279-000 (AP)		
	MS51957-30	2	SCREW,MACH SST, 6-32 X 1/2 (96906) 343-0171-000 (AP)	1	
53	642-2408-001	2	HARNES,WIRING	1	
	P313-0045-000	2	NUT,PLAIN,HEX SST, 6-32 (77250) 313-0045-000 (AP)	4	
	310-0071-000	2	WASHER,LOCK SST, 0.151 ID X 0.239 OD (79807) (AP)	4	
	MS51957-30	2	SCREW,MACH SST, 6-32 X 1/2 (96906) 343-0171-000 (AP)	4	
54	CK63AW103M	3	CAPACITOR,FXD CER DIEI, 10000PF, 20%, 500V (81349)	1	
			913-1188-000 C37		
55	CK63AW103M	3	CAPACITOR,FXD CER DIEI, 10000PF, 20%, 500V (81349)	1	
			913-1188-000 C35		
56	CK63AW103M	3	CAPACITOR,FXD CER DIEI, 10000PF, 20%, 500V (81349)	1	
			913-1188-000 C36		
57	CK63AW103M	3	CAPACITOR,FXD CER DIEI, 10000PF, 20%, 500V (81349)	1	
			913-1188-000 C34		
57A	CK63AW103M	3	CAPACITOR,FXD CER DIEI, 10000PF, 20%, 500V (81349)	1	
			913-1188-000 C38		
57B	CK63AW103M	3	CAPACITOR,FXD CER DIEI, 10000PF, 20%, 500V (81349)	1	
			913-1188-000 C39		
58	403	3	TERMINAL,LUG (79963) 304-1089-000	1	
59	353-18-10-001	3	TERMINAL STRIP (71785) 367-0018-000 TB1	1	
60	MS51957-15	2	SCREW,MACH STL, 4-40 X 3/8 (96906) 343-0135-000	3	
	MS35338-135	2	WASHER,LOCK SST, 0.115 ID X 0.209 OD (96906)	3	
			310-0279-000 (AP)		
	MS35649-244	2	NUT,PLAIN,HEX SST, 4-40 (96906) 313-0043-000 (AP)	3	
61	642-2407-001	2	HARNES,WIRING	1	
	P313-0045-000	2	NUT,PLAIN,HEX SST, 6-32 (77250) 313-0045-000 (AP)	4	
	310-0071-000	2	WASHER,LOCK SST, 0.151 ID X 0.239 OD (79807) (AP)	4	

GROUP ASSEMBLY PARTS LIST

FIG-ITEM	PART NO	INDENT	DESCRIPTION	UNITS PER ASSY	USABLE ON CODE
1-	MS51957-30	2	SCREW,MACH SST, 6-32 X 1/2 (96906) 343-0171-000 (AP)	4	
62	CK63AW103M	3	CAPACITOR,FXD CER DIEL, 10000PF, 20%, 500V (81349) 913-1188-000 C46	1	
63	CK63AW103M	3	CAPACITOR,FXD CER DIEL, 10000PF, 20%, 500V (81349) 913-1188-000 C47	1	
64	CK63AW103M	3	CAPACITOR,FXD CER DIEL, 10000PF, 20%, 500V (81349) 913-1188-000 C45	1	
65	CK63AW103M	3	CAPACITOR,FXD CER DIEL, 10000PF, 20%, 500V (81349) 913-1188-000 C44	1	
66	CK63AW103M	3	CAPACITOR,FXD CER DIEL, 10000PF, 20%, 500V (81349) 913-1188-000 C43	1	
66A	CK63AW103M	3	CAPACITOR,FXD CER DIEL, 10000PF, 20%, 500V (81349) 913-1188-000 C48	1	
67	403	3	TERMINAL,LUG (79963) 304-1089-000	2	
68	353-18-10-001	3	TERMINAL STRIP (71785) 367-0018-000 TB2	1	
69	P500	2	BUTTON,PL PLSTC (28520) 308-0312-020	4	A,B
69	P500	2	BUTTON,PL PLSTC (28520) 308-0312-020	2	C,D,E
70	642-0022-000	2	PLATE, IDENT	1	A
70	642-0020-000	2	PLATE, IDENT	1	B,C,D,E
71	MS51957-11	2	SCREW,MACH STL, 4-40 X 1/8 (96906) 343-0131-000 (AP)	2	
	635-9699-001	2	PLATE,COVER	1	
	P313-0045-000	2	NUT,PLAIN,HEX SST, 6-32 (77250) 313-0045-000 (AP)	2	
	310-0071-000	2	WASHER,LOCK SST, 0.151 ID X 0.239 OD (79807) (AP)	2	
	MS51957-28	2	SCREW,MACH SST, 6-32 X 3/8 (96906) 343-0169-000 (AP)	2	
72	634-8219-001	2	PLATE,COVER	1	
	MS35649-244	2	NUT,PLAIN,HEX SST, 4-40 (96906) 313-0043-000 (AP)	2	
	MS35338-135	2	WASHER,LOCK SST, 0.115 ID X 0.209 OD (96906) 310-0279-000 (AP)	2	
	MS51957-15	2	SCREW,MACH STL, 4-40 X 3/8 (96906) 343-0135-000 (AP)	2	
73	M24308-26-1	2	SCREW ASSY (81349) 371-0062-000	10	A
73	M24308-26-1	2	SCREW ASSY (81349) 371-0062-000	6	B,C,D,E
74			NOT USED		
75	P343-0311-000	2	SCREW,MACH NP BRS, 8-32 X 1/2 (77250) 343-0311-000	1	
	MS35338-99	2	WASHER,SPRING CD PL BRZ, 0.168 ID X 0.293 OD (96906) 310-0098-000 (AP)	1	
	310-0057-000	2	WASHER,FLAT BRS, 0.172 ID X 0.375 OD (79807) (AP)	1	
76	637-2712-001	2	RFI FILTER A24 (SEE FIG 6)	1	
	540-9006-003	2	POST,ELEC-MECH (AP)	2	
	MS51957-3	2	SCREW,MACH CD PL STL, 2-56 X 1/4 (96906) 343-0124-000 (AP)	4	
	MS35338-134	2	WASHER,LOCK SST, 0.088 ID X 0.172 OD (96906) 310-0275-000 (AP)	2	
77	17250	2	CABLE ASSY,PWR (70903) 426-1034-010	1	
78	637-9121-001	2	SUPPORT	1	
	P325-0051-000	2	SCREW,MACH STL, 10-32UNF-2A X 1/2 (77250) 325-0051-000 (AP)	2	
79	637-9295-001	2	LABEL,FEATURE	1	
80	280-2745-020	2	LABEL,PRESS SENS (12998)	1	
81	637-1769-001	2	KIT,MAINTENANCE	1	
82	AGC250-1	3	FUSE,CRTG (71400) 264-0721-000 (F1)	5	
83	AGC250-2	3	FUSE,CRTG (71400) 264-0723-000 (F1)	5	
84	MS25237-327-15	3	LAMP,INCAND (96906) 262-1106-000	1	
85	024-0057-000	3	KEY,SCH SCR (08664)	1	
86	024-0058-000	3	KEY,SCH SCR (08664)	1	
87	634-8177-001	2	CHASSIS	1	

1

1 CAUTION USE PROPER AMP FUSE FOR CORRECT VOLTAGE.



GROUP ASSEMBLY PARTS LIST

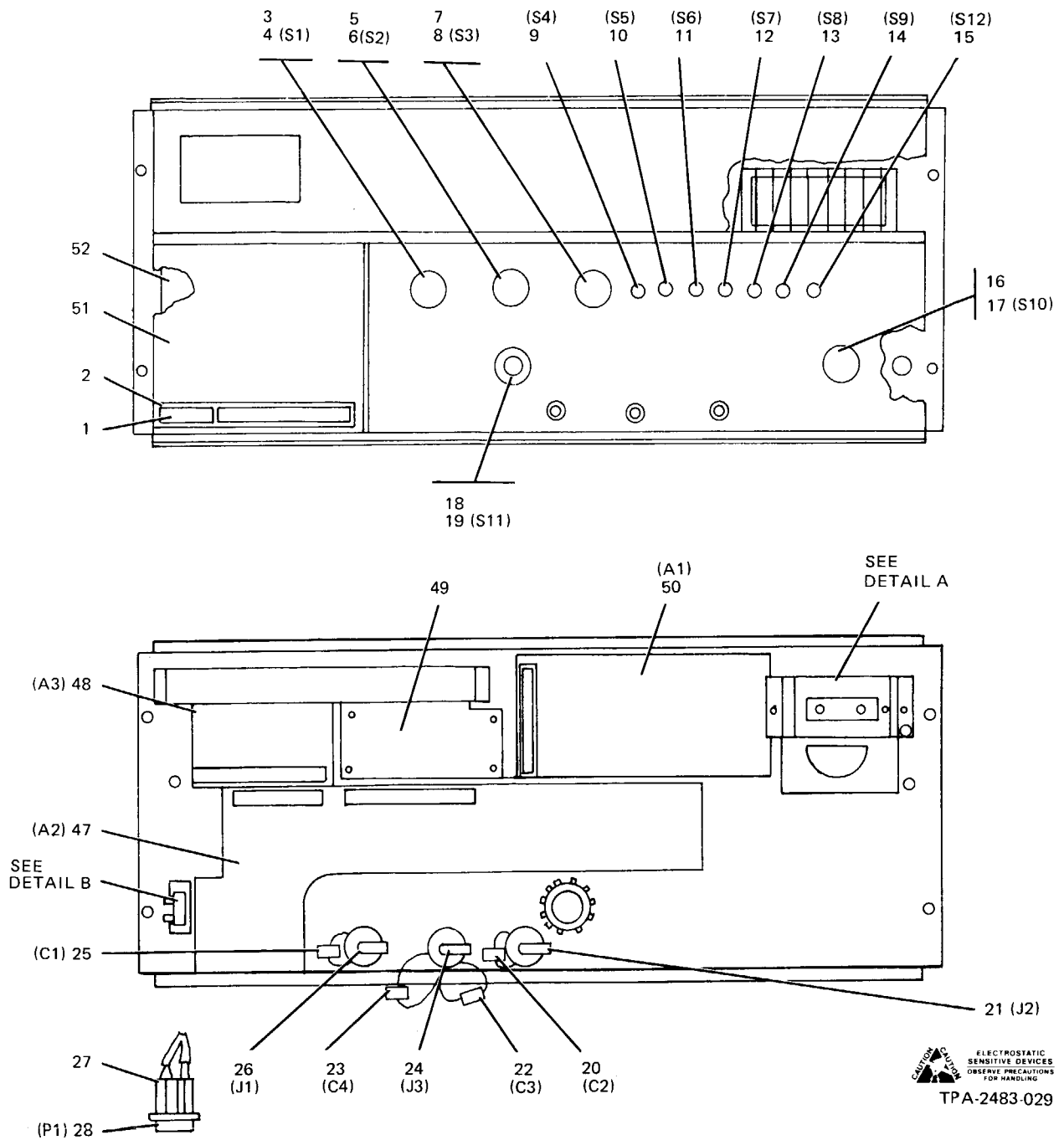

Front Panel A2  
Figure 2 (Sheet 1 of 2)

GROUP ASSEMBLY PARTS LIST

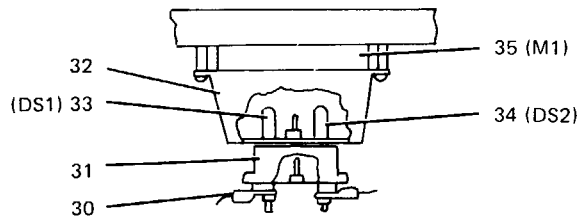

DETAIL A

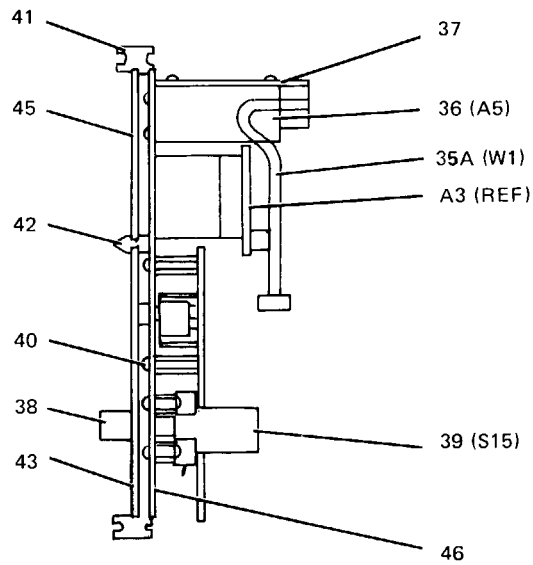

DETAIL B



TPA-2483-029

Front Panel A2  
Figure 2 (Sheet 2)

## GROUP ASSEMBLY PARTS LIST

FIG-ITEM	PART NO	INDENT	DESCRIPTION	UNITS PER ASSY	USABLE ON CODE
2-	634-8199-001	1	PANEL,FRONT A2 [ESDS] [SEE FIG 1-30 FOR NHA]		REF A,B
	634-8199-002	1	PANEL,FRONT A2 [ESDS] [SEE FIG 1-30 FOR NHA]		REF C,D,E
1	623-9008-001	2	INSERT, HOUSEMARK	1	
2	632-5201-001	2	HOLDER,INSERT	1	
	P313-0132-000	2	NUT,PLAIN,HEX SST, 4-40 (77250) 313-0132-000 (AP)	2	
	MS51959-12	2	SCREW,MACH SST, 4-40 X 3/16 (96906) 342-0043-000 (AP)	2	
3	RB67-1DCML	2	KNOB,RING SKRTD (86797) 281-0650-010	1	
	P313-0064-000	2	NUT,PLAIN,HEX SST, 3/8-32 (77250) 313-0064-000 (AP)	1	
4	280551BF1	2	SWITCH,RTRY (76854) 259-7201-230 A2S1	1	
5	RB67-1DCML	2	KNOB,RING SKRTD (86797) 281-0650-010	1	
	P313-0064-000	2	NUT,PLAIN,HEX SST, 3/8-32 (77250) 313-0064-000 (AP)	1	
6	280442BF1	2	SWITCH,RTRY (76854) 259-7201-080 A2S2	1	
7	RB67-1DCML	2	KNOB,RING SKRTD (86797) 281-0650-010	1	
	P313-0064-000	2	NUT,PLAIN,HEX SST, 3/8-32 (77250) 313-0064-000 (AP)	1	
8	280430BF1	2	SWITCH,RTRY (76854) 259-7201-070 A2S3	1	
9	7103P3PD9V40B	2	SWITCH,TGL (09353) 266-5415-120 A2S4	1	
10	7103P3PD9V40B	2	SWITCH,TGL (09353) 266-5415-120 A2S5	1	
11	7203P3PD9V40B	2	SWITCH,TGL (09353) 266-5415-150 A2S6	1	
12	7103P3PD9V40B	2	SWITCH,TGL (09353) 266-5415-120 A2S7	1	
13	7101P3PD9V40B	2	SWITCH,TGL (09353) 266-5415-130 A2S8	1	
14	7101P3PD9V40B	2	SWITCH,TGL (09353) 266-5415-130 A2S9	1	
15	7207P3PD9V40B	2	SWITCH,TGL (09353) 266-5415-170 A2S12	1	
16	RB67-1DCML	2	KNOB,RING SKRTD (86797) 281-0650-010	1	
	P313-0064-000	2	NUT,PLAIN,HEX SST, 3/8-32 (77250) 313-0064-000 (AP)	1	
17	280545BF1	2	SWITCH,RTRY (76854) 259-7201-220 A2S10	1	
18	RB67-1-0ML9	2	KNOB,CONCENTRIC (86797) 281-0650-030	1	
	P313-0064-000	2	NUT,PLAIN,HEX SST, 3/8-32 (77250) 313-0064-000 (AP)	1	
19	259-8017-040	2	SWITCH,RTRY (71590) A2S11	1	
20	CK63AW103M	2	CAPACITOR,FXD CER DIEI, 10000PF, 20%, 500V (81349) 913-1188-000 A2C2	1	
21	M641-6-1	2	JACK,TEL (81349) 358-1040-000 A2J2	1	
22	CK63AW103M	2	CAPACITOR,FXD CER DIEI, 10000PF, 20%, 500V (81349) 913-1188-000 A2C3	1	
23	CK63AW103M	2	CAPACITOR,FXD CER DIEI, 10000PF, 20%, 500V (81349) 913-1188-000 A2C4	1	
24	M641-5-1	2	JACK,TEL (81349) 358-1050-000 A2J3	1	
25	CK63AW103M	2	CAPACITOR,FXD CER DIEI, 10000PF, 20%, 500V (81349) 913-1188-000 A2C1	1	
26	M641-6-1	2	JACK,TEL (81349) 358-1040-000 A2J1	1	
27	60618-1	2	PIN CONTACT (00779) 372-5884-200	4	
28	1-480426-0	2	HOUSING,PIN (00779) 372-5884-480 A2P1	1	
29			NOT USED		
30	MS25036-144	2	TERMINAL,LUG (96906) 304-1251-000	7	
	P313-0051-000	2	NUT,PLAIN,HEX NP BRS, 4-40 (77250) 313-0051-000 (AP)	5	
	MS35338-135	2	WASHER,LOCK SST, 0.115 ID X 0.209 OD (96906) 310-0279-000 (AP)	3	
	310-6340-000	2	WASHER,FLAT SST, 0.125 ID X 0.281 OD (79807) (AP)	2	
	P343-0285-000	2	SCREW,MACH NP BRS, 4-40 X 1/4 (77250) 343-0285-000 (AP)	1	
	MS51957-18B	2	SCREW,MACH SST, 4-40 X 5/8 (96906) 343-0024-000 (AP)	2	
31	637-1779-001	2	BLOCK,INSULATOR	1	
32	635-9614-001	2	BRACKET,LIGHT	1	
33	MS25237-327-15	2	LAMP,INCAND (96906) 262-1106-000 A2DS1	1	
34	MS25237-327-15	2	LAMP,INCAND (96906) 262-1106-000 A2DS2	1	
35	7521	2	METER,DC AMP 45 OHMS RES (65092) 450-0151-010 A2M1	1	
	340-1010-000	2	SPRING,HELICAL (91314) (AP FOR 31-35)	1	
	P343-0291-000	2	SCREW,MACH NP BRS, 4-40 X 3/4 (77250) 343-0291-000 (AP FOR 31-35)	3	
35A	634-8289-001	2	CABLE,FREQUENCY DISPLAY A2M1		1 C,D,E
36	637-1781-006	2	FREQUENCY DISPLAY A2A5 [ESDS]		1 C,D,E
37	637-1546-001	2	BRACKET		2 C,D,E
	MS51957-3B	2	SCREW,MACH SST, 2-56 X 1/4 (96906) 343-0072-000 (AP)		8 C,D,E

GROUP ASSEMBLY PARTS LIST

FIG-ITEM	PART NO	INDENT	DESCRIPTION	UNITS PER ASSY	USABLE ON CODE
2-	MS35338-134	2	WASHER, LOCK SST, 0.088 ID X 0.172 OD (96906) 310-0275-000 (AP)	4	C, D, E
	310-6340-000	2	WASHER, FLAT SST, 0.125 ID X 0.281 OD (79807) (AP)	4	C, D, E
38	F1-15H4	2	BUTTON, PUSH (31918) 266-7508-210	1	
39	NE15F01-0003-00	2	SWITCH, PUSH (31918) 266-7524-010 A2S15	1	
	MS51957-3B	2	SCREW, MACH SST, 2-56 X 1/4 (96906) 343-0072-000 (AP)	4	
	MS35338-134	2	WASHER, LOCK SST, 0.088 ID X 0.172 OD (96906) 310-0275-000 (AP)	4	
	540-9006-003	2	POST, HEX (AP)	2	
40	540-9096-003	2	POST, HEX	3	
	MS51957-3B	2	SCREW, MACH SST, 2-56 X 1/4 (96906) 343-0072-000 (AP)	6	
	MS35338-134	2	WASHER, LOCK SST, 0.088 ID X 0.172 OD (96906) 310-0275-000 (AP)	3	
41	635-9601-001	2	BAR, EDGE	1	
	MS51957-13B	2	SCREW, MACH SST, 4-40 X 1/4 (96906) 343-0019-000 (AP)	8	
	MS35338-135	2	WASHER, LOCK SST, 0.115 ID X 0.209 OD (96906) 310-0279-000 (AP)	8	
42	635-9615-001	2	SUPPORT, PANEL	1	
	MS51957-13B	2	SCREW, MACH SST, 4-40 X 1/4 (96906) 343-0019-000 (AP)	4	
	MS35338-135	2	WASHER, LOCK SST, 0.115 ID X 0.209 OD (96906) 310-0279-000 (AP)	4	
43	634-8189-001	2	OVERLAY, LOWER	1	
44			NOT USED		
45	635-9625-006	2	OVERLAY, UPPER	1	
46	635-9603-001	2	PANEL, SWITCH	1	
47	638-6597-001	2	BOARD, MOUNTING A2A2 (SEE FIG 3)	1	
48	635-0830-001	2	FREQUENCY SWITCHBOARD A2A3	1	
	MS35649-224	2	NUT, PLAIN, HEX SST, 2-56 (96906) 313-0037-000 (AP)	4	
	MS35338-134	2	WASHER, LOCK SST, 0.088 ID X 0.172 OD (96906) 310-0275-000 (AP)	4	
	MS51957-5B	2	SCREW, MACH SST, 2-56 X 3/8 (96906) 343-0674-000 (AP)	4	
49	635-9696-001	2	PLATE, FILLER	1	A, B
49	634-8273-001	2	PLATE, FILLER	1	C, D, E
	MS35649-224	2	NUT, PLAIN, HEX SST, 2-56 (96906) 313-0037-000 (AP)	5	A, B
	MS35649-224	2	NUT, PLAIN, HEX SST, 2-56 (96906) 313-0037-000 (AP)	4	C, D, E
	MS35338-134	2	WASHER, LOCK SST, 0.088 ID X 0.172 OD (96906) 310-0275-000 (AP)	5	A, B
	MS35338-134	2	WASHER, LOCK SST, 0.088 ID X 0.172 OD (96906) 310-0275-000 (AP)	4	C, D, E
	MS51957-5B	2	SCREW, MACH SST, 2-56 X 3/8 (96906) 343-0674-000 (AP)	5	A, B
	MS51957-5B	2	SCREW, MACH SST, 2-56 X 3/8 (96906) 343-0674-000 (AP)	4	C, D, E
50	635-0825-012	2	LED STATUS DISPLAY A2A1	1	
	MS51957-3B	2	SCREW, MACH SST, 2-56 X 1/4 (96906) 343-0072-000 (AP)	8	
	MS35338-134	2	WASHER, LOCK SST, 0.088 ID X 0.172 OD (96906) 310-0275-000 (AP)	4	
	540-9006-003	2	POST, ELEC-MECH (AP)	4	
51	635-9602-001	2	GRILL, SPEAKER	1	
52	637-1547-001	2	BAFFLE, SPEAKER	1	

GROUP ASSEMBLY PARTS LIST

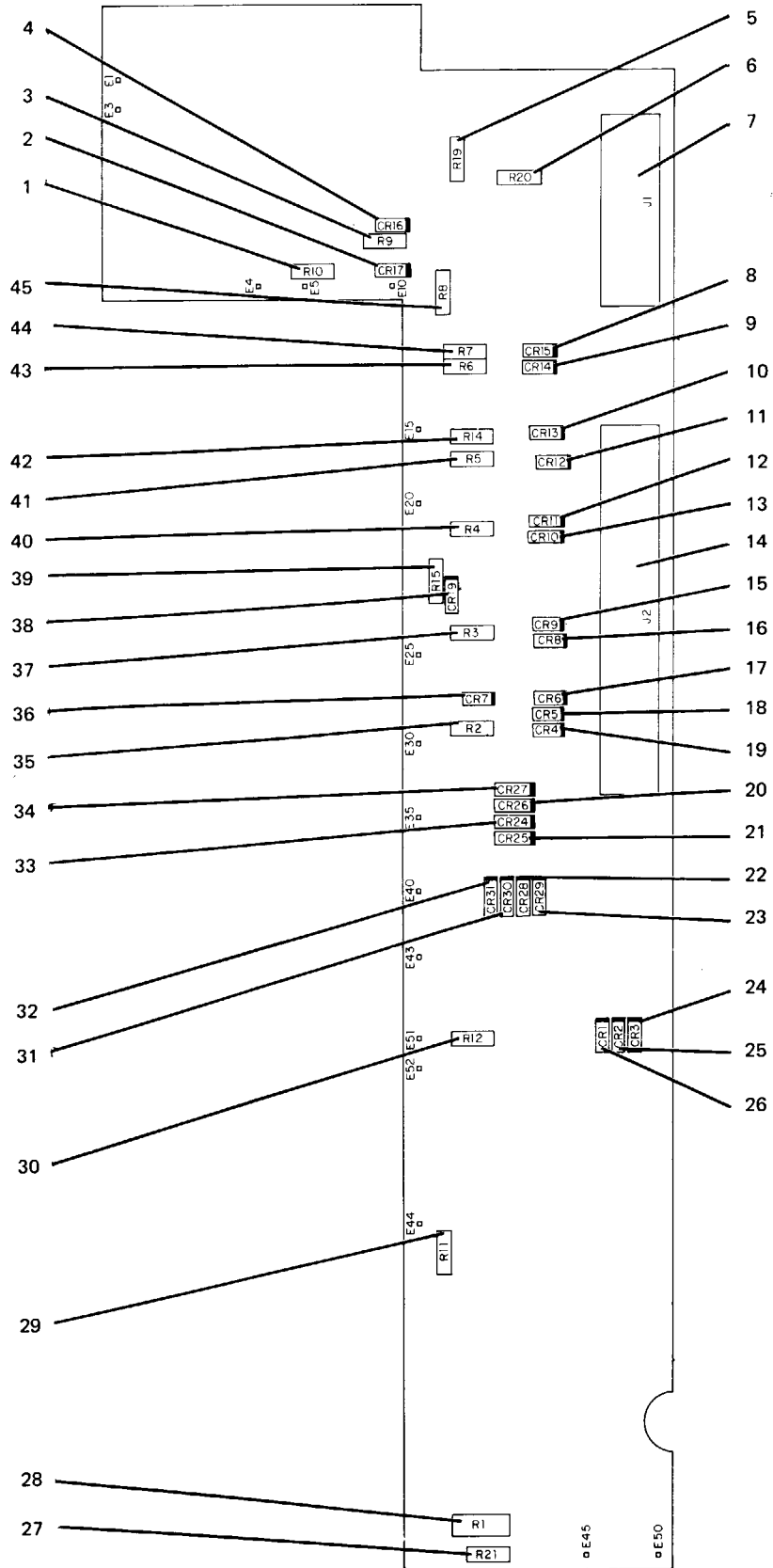

Mounting Board A2A2  
Figure 3

## GROUP ASSEMBLY PARTS LIST

FIG-ITEM	PART NO	INDENT	DESCRIPTION	UNITS PER ASSY	USABLE ON CODE
3-	638-6597-001		1 BOARD, MOUNTING A2A2 (SEE FIG 2-47 FOR NHA)		REF
1	RCR07G271KS		2 RESISTOR,FXD CMPSN, 270 OHMS, 10%, 1/4W (81349) 745-0728-000 A2A2R10		1
2	1N4454GE		2 SEMICOND DEVICE (03508) 353-3644-010 A2A2CR17		1
3	RCR07G271KS		2 RESISTOR,FXD CMPSN, 270 OHMS, 10%, 1/4W (81349) 745-0728-000 A2A2R9		1
4	1N4454GE		2 SEMICOND DEVICE (03508) 353-3644-010 A2A2CR16		1
5	RCR07G105KS		2 RESISTOR,FXD CMPSN, 1MEGO, 10%, 1/4W (81349) 745-0857-000 A2A2R19		1
6	RCR07G104KS		2 RESISTOR,FXD CMPSN, 0.10MEGO, 10%, 1/4W (81349) 745-0821-000 A2A2R20		1
7	87478-4		2 HOUSING,CONN,EL (00779) 372-0043-410 A2A2J1		1
8	1N4454GE		2 SEMICOND DEVICE (03508) 353-3644-010 A2A2CR15		1
9	1N4454GE		2 SEMICOND DEVICE (03508) 353-3644-010 A2A2CR14		1
10	1N4454GE		2 SEMICOND DEVICE (03508) 353-3644-010 A2A2CR13		1
11	1N4454GE		2 SEMICOND DEVICE (03508) 353-3644-010 A2A2CR12		1
12	1N4454GE		2 SEMICOND DEVICE (03508) 353-3644-010 A2A2CR11		1
13	1N4454GE		2 SEMICOND DEVICE (03508) 353-3644-010 A2A2CR10		1
14	87478-8		2 HOUSING,CONN,EL (00779) 372-0043-530 A2A2J2		1
15	1N4454GE		2 SEMICOND DEVICE (03508) 353-3644-010 A2A2CR9		1
16	1N4454GE		2 SEMICOND DEVICE (03508) 353-3644-010 A2A2CR8		1
17	1N4454GE		2 SEMICOND DEVICE (03508) 353-3644-010 A2A2CR6		1
18	1N4454GE		2 SEMICOND DEVICE (03508) 353-3644-010 A2A2CR5		1
19	1N4454GE		2 SEMICOND DEVICE (03508) 353-3644-010 A2A2CR4		1
20	1N4454GE		2 SEMICOND DEVICE (03508) 353-3644-010 A2A2CR26		1
21	1N4454GE		2 SEMICOND DEVICE (03508) 353-3644-010 A2A2CR25		1
22	1N4454GE		2 SEMICOND DEVICE (03508) 353-3644-010 A2A2CR28		1
23	1N4454GE		2 SEMICOND DEVICE (03508) 353-3644-010 A2A2CR29		1
24	1N4454GE		2 SEMICOND DEVICE (03508) 353-3644-010 A2A2CR3		1
25	1N4454GE		2 SEMICOND DEVICE (03508) 353-3644-010 A2A2CR2		1
26	1N4454GE		2 SEMICOND DEVICE (03508) 353-3644-010 A2A2CR1		1
27	RN55D16R9F		2 RESISTOR,FXD FILM, 16.9 OHMS, 1%, 1/8W (81349) 705-0911-000 A2A2R21		1
28	RN55D1540F		2 RESISTOR,FXD FILM, 154 OHMS, 1%, 1/8W (81349) 705-0957-000 A2A2R1		1
29	RCR07G271KS		2 RESISTOR,FXD CMPSN, 270 OHMS, 10%, 1/4W (81349) 745-0728-000 A2A2R11		1
30	RCR07G271KS		2 RESISTOR,FXD CMPSN, 270 OHMS, 10%, 1/4W (81349) 745-0728-000 A2A2R12		1
31	1N4454GE		2 SEMICOND DEVICE (03508) 353-3644-010 A2A2CR30		1
32	1N4454GE		2 SEMICOND DEVICE (03508) 353-3644-010 A2A2CR31		1
33	1N4454GE		2 SEMICOND DEVICE (03508) 353-3644-010 A2A2CR24		1
34	1N4454GE		2 SEMICOND DEVICE (03508) 353-3644-010 A2A2CR27		1
35	RCR07G271KS		2 RESISTOR,FXD CMPSN, 270 OHMS, 10%, 1/4W (81349) 745-0728-000 A2A2R2		1
36	1N4454GE		2 SEMICOND DEVICE (03508) 353-3644-010 A2A2CR7		1
37	RCR07G271KS		2 RESISTOR,FXD CMPSN, 270 OHMS, 10%, 1/4W (81349) 745-0728-000 A2A2R3		1
38	1N4454GE		2 SEMICOND DEVICE (03508) 353-3644-010 A2A2CR19		1
39	RCR07G271KS		2 RESISTOR,FXD CMPSN, 270 OHMS, 10%, 1/4W (81349) 745-0728-000 A2A2R15		1
40	RCR07G271KS		2 RESISTOR,FXD CMPSN, 270 OHMS, 10%, 1/4W (81349) 745-0728-000 A2A2R4		1
41	RCR07G271KS		2 RESISTOR,FXD CMPSN, 270 OHMS, 10%, 1/4W (81349) 745-0728-000 A2A2R5		1
42	RCR07G223KS		2 RESISTOR,FXD CMPSN, 22K, 10%, 1/4W (81349) 745-0797-000 A2A2R14		1
43	RCR07G271KS		2 RESISTOR,FXD CMPSN, 270 OHMS, 10%, 1/4W (81349) 745-0728-000 A2A2R6		1
44	RCR07G271KS		2 RESISTOR,FXD CMPSN, 270 OHMS, 10%, 1/4W (81349) 745-0728-000 A2A2R7		1
45	RCR07G223KS		2 RESISTOR,FXD CMPSN, 22K, 10%, 1/4W (81349) 745-0797-000 A2A2R8		1

GROUP ASSEMBLY PARTS LIST

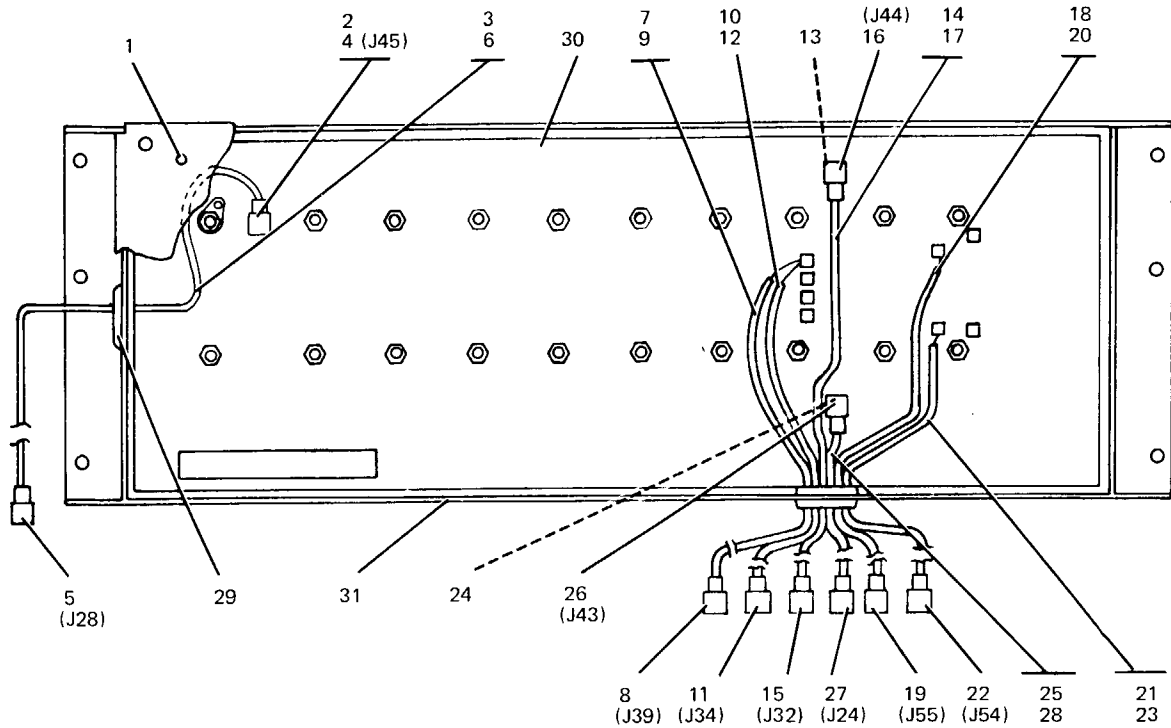

TPA-2473-019

Synthesizer Chassis A27  
Figure 4

FIG-ITEM	PART NO	INDENT	DESCRIPTION	UNITS PER ASSY	USABLE ON CODE
4-	634-8201-001	1	CHASSIS, SYNTHESIZER A27 (SEE FIG 1-33 FOR NHA)	REF	
1	634-8186-001	2	COVER,BOTTOM	1	
	MS51957-3	2	SCREW,MACH CD PL STL, 2-56 X 1/4 (96906) 343-0124-000 (AP)	6	
	MS35338-134	2	WASHER,LOCK SST, 0.088 ID X 0.172 OD (96906) 310-0275-000 (AP)	6	
2	623-1379-001	2	BUSHING	1	
3	637-1526-003	2	CABLE ASSY, RF COAXIAL	1	
	4007-4HT	2	TERMINAL,LUG (77147) 304-0015-000 (AP)	1	
4	52-312-9040	3	CONNECTOR,RCPT ELEC (98291) 357-7207-220 A27J45	1	
5	52-312-9040	3	CONNECTOR,RCPT ELEC (98291) 357-7207-220 A27J28	1	
6	RG178BU	3	CABLE,RF (81349) 425-1538-000	AR	
7	637-1529-001	2	CABLE ASSY, RF COAXIAL	1	
8	52-312-9094	3	JACK,RA,BLKHD (98291) 357-7207-320 A27J39	1	
9	RG178BU	3	CABLE,RF (81349) 425-1538-000	AR	
10	637-1529-001	2	CABLE ASSY, RF COAXIAL	1	
11	52-312-9094	3	JACK,RA,BLKHD (98291) 357-7207-320 A27J34	1	
12	RG178BU	3	CABLE,RF (81349) 425-1538-000	AR	
13	623-1379-001	2	BUSHING	1	
14	637-1526-006	2	CABLE ASSY,RF COAXIAL	1	

GROUP ASSEMBLY PARTS LIST

FIG-ITEM	PART NO	INDENT	DESCRIPTION	UNITS PER ASSY	USABLE ON CODE
4-15	52-312-9040	3	CONNECTOR,RCPT ELEC (98291) 357-7207-220 A27J32	1	
16	52-312-9040	3	CONNECTOR,RCPT ELEC (98291) 357-7207-220 A27J44	1	
17	RG178BU	3	CABLE,RF (81349) 425-1538-000	AR	
18	637-1529-001	2	CABLE ASSY, RF COAXIAL	1	
19	52-312-9094	3	JACK,RA,BLKHD (98291) 357-7207-320 A27J55	1	
20	RG178BU	3	CABLE,RF (81349) 425-1538-000	AR	
21	637-1529-001	2	CABLE ASSY, RF COAXIAL	1	
22	52-312-9094	3	JACK,RA,BLKHD (98291) 357-7207-320 A27J54	1	
23	425-1528-000	3	CABLE,SP,ELEC (71124)	AR	
24	623-1379-001	2	BUSHING	1	
25	637-1526-003	2	CABLE ASSY, RF COAXIAL	1	
26	52-312-9040	3	CONNECTOR,RCPT ELEC (98291) 357-7207-220 A27J43	1	
27	52-312-9040	3	CONNECTOR,RCPT ELEC (98291) 357-7207-220 A27J24	1	
28	425-1528-000	3	CABLE,SP,ELEC (71124)	AR	
29	7-50-60	2	GROMMET,RBR (77969) 201-0088-000	2	
30	638-6973-001	2	SIDEBBOARD, SYNTHESIZER (SEE FIG 5)	1	
	P313-0156-00	2	NUT,PLAIN,HEX NP BRS, 4-40 (77250) 313-0156-000 (AP)	22	
	MS35338-97	2	WASHER,SPRING CD PL BRZ, 0.115 ID X 0.209 OD (96906)	22	
			310-0095-000 (AP)		
	DIE845	2	WASHER,FLAT SST, 0.119 ID X 0.218 OD (72606)	22	
			310-0460-000 (AP)		
	P343-0289-000	2	SCREW,MACH NP BRS, 4-40 X 1/2 (77250) 343-0289-000 (AP)	22	
31	634-8178-001	2	CHASSIS,PRSD	1	



GROUP ASSEMBLY PARTS LIST

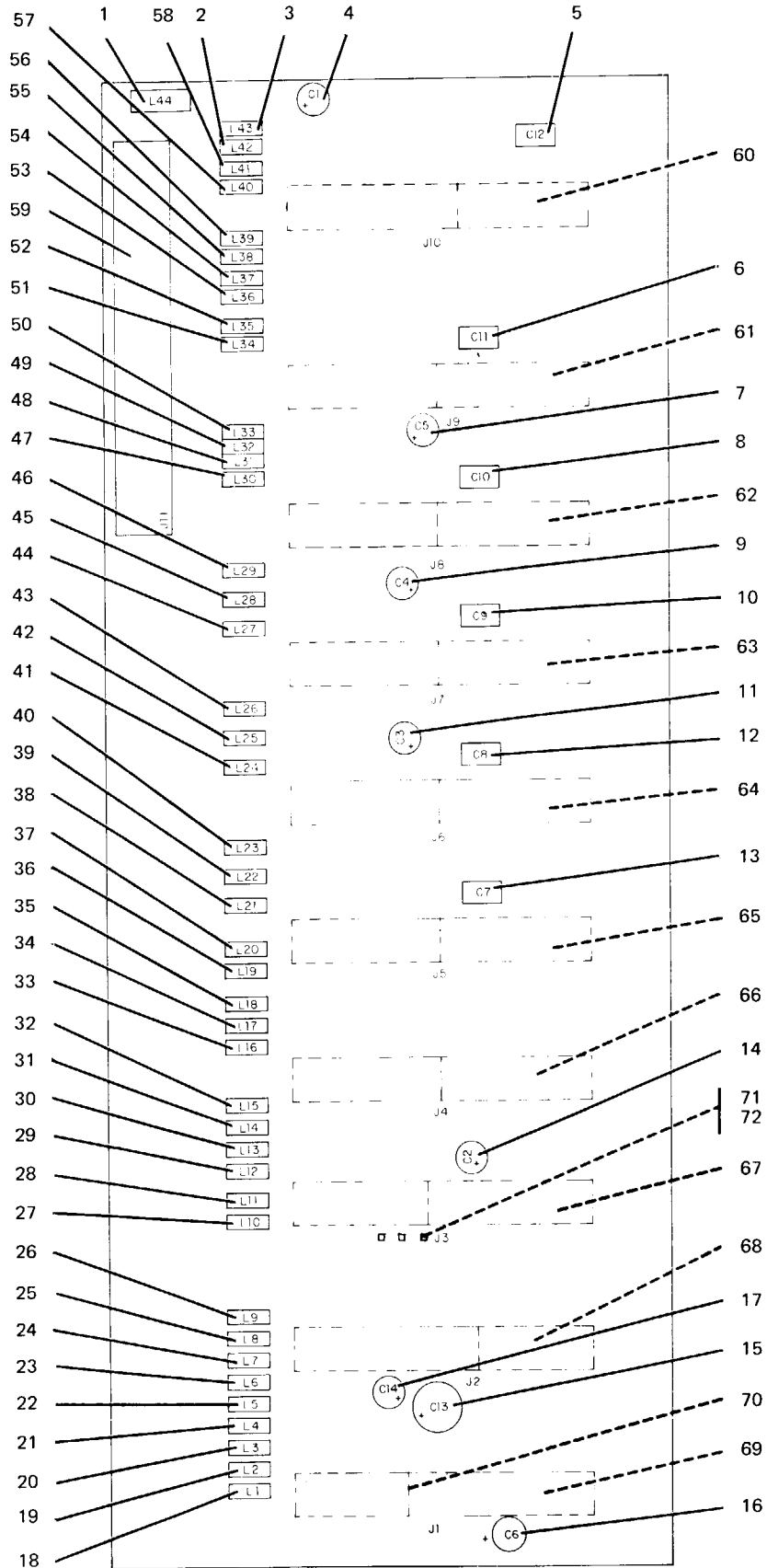

Synthesizer Sideboard (P/O A27)  
Figure 5

TPA-2489-019

GROUP ASSEMBLY PARTS LIST

FIG-ITEM	PART NO	INDENT	DESCRIPTION	UNITS PER ASSY	USABLE ON CODE
5-	638-6973-001	1	SIDEBBOARD, SYNTHESIZER P/O A27 (SEE FIG 4-30 FOR NHA)	REF	
1	MS75089-11	2	COIL,RF 100UH (96906) 240-2715-370 A27L44	1	
2	MS75085-07	2	COIL,RF 100UH (96906) 240-2047-000 A27L42	1	
3	MS75085-07	2	COIL,RF 100UH (96906) 240-2047-000 A27L43	1	
4	199D336X00100B1	2	CAPACITOR,FXD TNTLM ELCTLT, 33UF, 20%, 10V (56289) 184-9102-090 A27C1	1	
5	CD5FY151J0	2	CAPACITOR,FXD MICA DIEL, 150PF, 5%, 50V (93790) 912-4141-400 A27C12	1	
6	CD5FY151J0	2	CAPACITOR,FXD MICA DIEL, 150PF, 5%, 50V (93790) 912-4141-400 A27C11	1	
7	199D336X00100B1	2	CAPACITOR,FXD TNTLM ELCTLT, 33UF, 20%, 10V (56289) 184-9102-090 A27C5	1	
8	CD5FY151J0	2	CAPACITOR,FXD MICA DIEL, 150PF, 5%, 50V (93790) 912-4141-400 A27C10	1	
9	199D336X00100B1	2	CAPACITOR,FXD TNTLM ELCTLT, 33UF, 20%, 10V (56289) 184-9102-090 A27C4	1	
10	CD5FY151J0	2	CAPACITOR,FXD MICA DIEL, 150PF, 5%, 50V (93790) 912-4141-400 A27C9	1	
11	199D336X00100B1	2	CAPACITOR,FXD TNTLM ELCTLT, 33UF, 20%, 10V (56289) 184-9102-090 A27C3	1	
12	CD5FY151J0	2	CAPACITOR,FXD MICA DIEL, 150PF, 5%, 50V (93790) 912-4141-400 A27C8	1	
13	CD5FY151J0	2	CAPACITOR,FXD MICA DIEL, 150PF, 5%, 50V (93790) 912-4141-400 A27C7	1	
14	199D336X00100B1	2	CAPACITOR,FXD TNTLM ELCTLT, 33UF, 20%, 10V (56289) 184-9102-090 A27C2	1	
15	199D1009	2	CAPACITOR,FXD TNTLM ELCTLT, 33UF, 20%, 25V (56289) 184-9102-260 A27C13	1	
16	199D475X0035DE3	2	CAPACITOR,FXD TNTLM ELCTLT, 4.7UF, 20%, 35V (56289) 184-9102-830 A27C6	1	
17	199D336X00100B1	2	CAPACITOR,FXD TNTLM ELCTLT, 33UF, 20%, 10V (56289) 184-9102-090 A27C14	1	
18	MS75085-07	2	COIL,RF 100UH (96906) 240-2047-000 A27L1	1	
19	MS75085-07	2	COIL,RF 100UH (96906) 240-2047-000 A27L2	1	
20	MS75085-07	2	COIL,RF 100UH (96906) 240-2047-000 A27L3	1	
21	MS75085-07	2	COIL,RF 100UH (96906) 240-2047-000 A27L4	1	
22	MS75085-07	2	COIL,RF 100UH (96906) 240-2047-000 A27L5	1	
23	MS75085-07	2	COIL,RF 100UH (96906) 240-2047-000 A27L6	1	
24	MS75085-07	2	COIL,RF 100UH (96906) 240-2047-000 A27L7	1	
25	MS75085-07	2	COIL,RF 100UH (96906) 240-2047-000 A27L8	1	
26	MS75085-07	2	COIL,RF 100UH (96906) 240-2047-000 A27L9	1	
27	MS75085-07	2	COIL,RF 100UH (96906) 240-2047-000 A27L10	1	
28	MS75085-07	2	COIL,RF 100UH (96906) 240-2047-000 A27L11	1	
29	MS75085-07	2	COIL,RF 100UH (96906) 240-2047-000 A27L12	1	
30	MS75085-07	2	COIL,RF 100UH (96906) 240-2047-000 A27L13	1	
31	MS75085-07	2	COIL,RF 100UH (96906) 240-2047-000 A27L14	1	
32	MS75085-07	2	COIL,RF 100UH (96906) 240-2047-000 A27L15	1	
33	MS75085-07	2	COIL,RF 100UH (96906) 240-2047-000 A27L16	1	
34	MS75085-07	2	COIL,RF 100UH (96906) 240-2047-000 A27L17	1	
35	MS75085-07	2	COIL,RF 100UH (96906) 240-2047-000 A27L18	1	
36	MS75085-07	2	COIL,RF 100UH (96906) 240-2047-000 A27L19	1	
37	MS75085-07	2	COIL,RF 100UH (96906) 240-2047-000 A27L20	1	
38	MS75085-07	2	COIL,RF 100UH (96906) 240-2047-000 A27L21	1	
39	MS75085-07	2	COIL,RF 100UH (96906) 240-2047-000 A27L22	1	
40	MS75085-07	2	COIL,RF 100UH (96906) 240-2047-000 A27L23	1	
41	MS75085-07	2	COIL,RF 100UH (96906) 240-2047-000 A27L24	1	
42	MS75085-07	2	COIL,RF 100UH (96906) 240-2047-000 A27L25	1	
43	MS75085-07	2	COIL,RF 100UH (96906) 240-2047-000 A27L26	1	
44	MS75085-07	2	COIL,RF 100UH (96906) 240-2047-000 A27L27	1	
45	MS75085-07	2	COIL,RF 100UH (96906) 240-2047-000 A27L28	1	
46	MS75085-07	2	COIL,RF 100UH (96906) 240-2047-000 A27L29	1	
47	MS75085-07	2	COIL,RF 100UH (96906) 240-2047-000 A27L30	1	
48	MS75085-07	2	COIL,RF 100UH (96906) 240-2047-000 A27L31	1	

## GROUP ASSEMBLY PARTS LIST

FIG-ITEM	PART NO	INDENT	DESCRIPTION	UNITS PER ASSY	USABLE ON CODE
5-49	MS75085-07	2	COIL,RF 100UH (96906) 240-2047-000 A27L32	1	
50	MS75085-07	2	COIL,RF 100UH (96906) 240-2047-000 A27L33	1	
51	MS75085-07	2	COIL,RF 100UH (96906) 240-2047-000 A27L34	1	
52	MS75085-07	2	COIL,RF 100UH (96906) 240-2047-000 A27L35	1	
53	MS75085-07	2	COIL,RF 100UH (96906) 240-2047-000 A27L36	1	
54	MS75085-07	2	COIL,RF 100UH (96906) 240-2047-000 A27L37	1	
55	MS75085-07	2	COIL,RF 100UH (96906) 240-2047-000 A27L38	1	
56	MS75085-07	2	COIL,RF 100UH (96906) 240-2047-000 A27L39	1	
57	MS75085-07	2	COIL,RF 100UH (96906) 240-2047-000 A27L40	1	
58	MS75085-07	2	COIL,RF 100UH (96906) 240-2047-000 A27L41	1	
59	87478-8	2	HOUSING,CONN,EL (00779) 372-0043-530 A27J11	1	
60	3VN10-1CDD3	2	CONNECTOR,RCPT ELEC (05574) 372-7086-010 A27J10	1	
61	3VN10-1CDD3	2	CONNECTOR,RCPT ELEC (05574) 372-7086-010 A27J9	1	
62	3VN10-1CDD3	2	CONNECTOR,RCPT ELEC (05574) 372-7086-010 A27J8	1	
63	3VN10-1CDD3	2	CONNECTOR,RCPT ELEC (05574) 372-7086-010 A27J7	1	
64	3VN10-1CDD3	2	CONNECTOR,RCPT ELEC (05574) 372-7086-010 A27J6	1	
65	3VN10-1CDD3	2	CONNECTOR,RCPT ELEC (05574) 372-7086-010 A27J5	1	
66	3VN10-1CDD3	2	CONNECTOR,RCPT ELEC (05574) 372-7086-010 A27J4	1	
67	3VN10-1CDD3	2	CONNECTOR,RCPT ELEC (05574) 372-7086-010 A27J3	1	
68	3VN10-1CDD3	2	CONNECTOR,RCPT ELEC (05574) 372-7086-010 A27J2	1	
69	3VN10-1CDD3	2	CONNECTOR,RCPT ELEC (05574) 372-7086-010 A27J1	1	
70	091-0071-000	2	CONNECTOR,RCPT ELEC (05574) 372-7600-270	10	
71	372-2601-012	2	CONTACT,ELEC	8	
72	M153SBRTTIN	2	EYELET,MTLC COP, 0.047 DIA X 0.085 (23730) 307-1270-000	8	

GROUP ASSEMBLY PARTS LIST

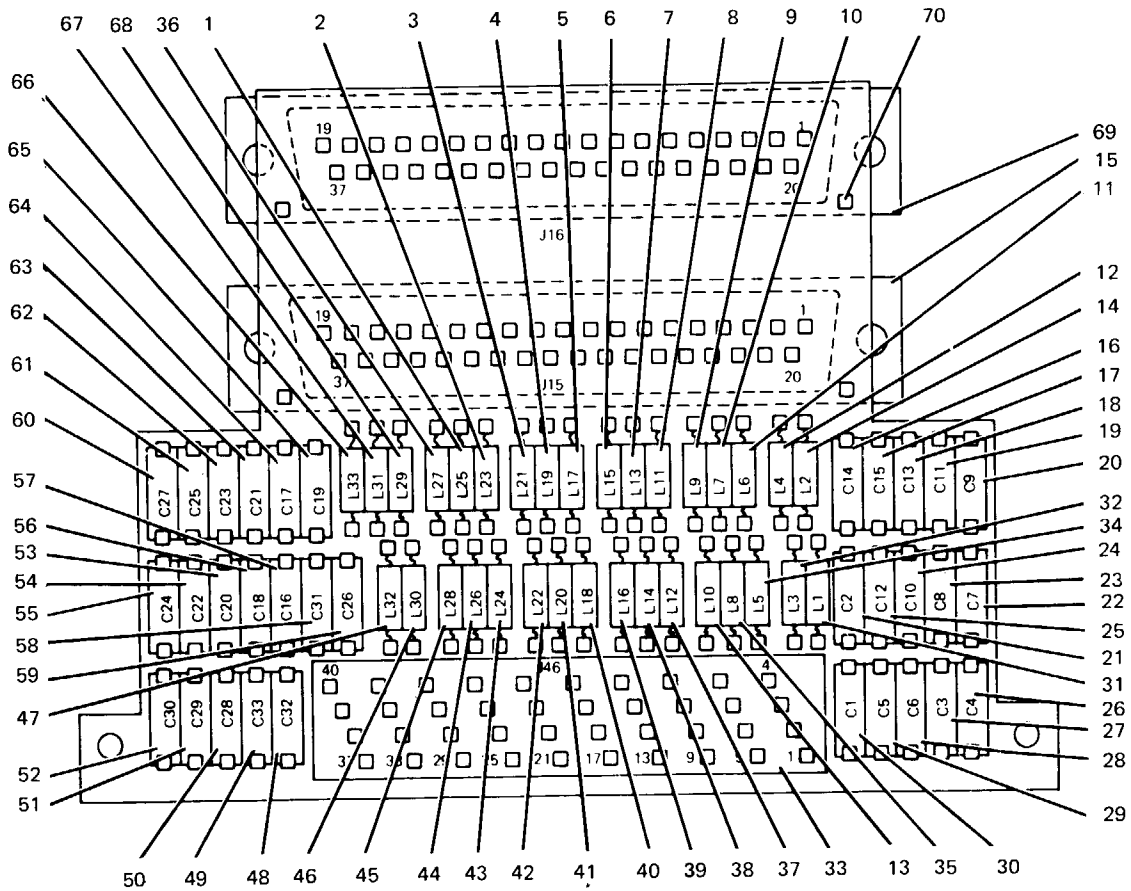

TPA-2864-019

RFI Filter A24  
Figure 6

## GROUP ASSEMBLY PARTS LIST

FIG-ITEM	PART NO	INDENT	DESCRIPTION	UNITS PER ASSY	USABLE ON CODE
6-	637-2712-001	1	RFI FILTER A24 (SEE FIG 1-76 FOR NHA)		REF
1	MS75085-07	2	COIL,RF 100UH (96906) 240-2047-000 A24L25	1	
2	MS75085-07	2	COIL,RF 100UH (96906) 240-2047-000 A24L23	1	
3	MS75085-07	2	COIL,RF 100UH (96906) 240-2047-000 A24L21	1	
4	MS75085-07	2	COIL,RF 100UH (96906) 240-2047-000 A24L19	1	
5	MS75085-07	2	COIL,RF 100UH (96906) 240-2047-000 A24L17	1	
6	MS75085-07	2	COIL,RF 100UH (96906) 240-2047-000 A24L15	1	
7	MS75085-07	2	COIL,RF 100UH (96906) 240-2047-000 A24L13	1	
8	MS75085-07	2	COIL,RF 100UH (96906) 240-2047-000 A24L11	1	
9	MS75085-07	2	COIL,RF 100UH (96906) 240-2047-000 A24L9	1	
10	MS75085-07	2	COIL,RF 100UH (96906) 240-2047-000 A24L7	1	
11	MS75085-07	2	COIL,RF 100UH (96906) 240-2047-000 A24L6	1	
12	MS75085-07	2	COIL,RF 100UH (96906) 240-2047-000 A24L4	1	
13	MS75085-07	2	COIL,RF 100UH (96906) 240-2047-000 A24L10	1	
14	MS75085-07	2	COIL,RF 100UH (96906) 240-2047-000 A24L2	1	
15	DCU37PBB	2	CONNECTOR,PLUG ELEC (71468) 371-0385-090 A24J15	1	
16	805-014X5V0103Z	2	CAPACITOR,FXD CER DIEI, 0.01UF, M20XP80Z, 100V (12294) 913-3680-000 A24C14	1	
17	805-014X5V0103Z	2	CAPACITOR,FXD CER DIEI, 0.01UF, M20XP80Z, 100V (12294) 913-3680-000 A24C15	1	
18	805-014X5V0103Z	2	CAPACITOR,FXD CER DIEI, 0.01UF, M20XP80Z, 100V (12294) 913-3680-000 A24C13	1	
19	805-014X5V0103Z	2	CAPACITOR,FXD CER DIEI, 0.01UF, M20XP80Z, 100V (12294) 913-3680-000 A24C11	1	
20	805-014X5V0103Z	2	CAPACITOR,FXD CER DIEI, 0.01UF, M20XP80Z, 100V (12294) 913-3680-000 A24C9	1	
21	805-014X5V0103Z	2	CAPACITOR,FXD CER DIEI, 0.01UF, M20XP80Z, 100V (12294) 913-3680-000 A24C2	1	
22	805-014X5V0103Z	2	CAPACITOR,FXD CER DIEI, 0.01UF, M20XP80Z, 100V (12294) 913-3680-000 A24C7	1	
23	805-014X5V0103Z	2	CAPACITOR,FXD CER DIEI, 0.01UF, M20XP80Z, 100V (12294) 913-3680-000 A24C8	1	
24	805-014X5V0103Z	2	CAPACITOR,FXD CER DIEI, 0.01UF, M20XP80Z, 100V (12294) 913-3680-000 A24C10	1	
25	805-014X5V0103Z	2	CAPACITOR,FXD CER DIEI, 0.01UF, M20XP80Z, 100V (12294) 913-3680-000 A24C12	1	
26	805-014X5V0103Z	2	CAPACITOR,FXD CER DIEI, 0.01UF, M20XP80Z, 100V (12294) 913-3680-000 A24C4	1	
27	805-014X5V0103Z	2	CAPACITOR,FXD CER DIEI, 0.01UF, M20XP80Z, 100V (12294) 913-3680-000 A24C3	1	
28	805-014X5V0103Z	2	CAPACITOR,FXD CER DIEI, 0.01UF, M20XP80Z, 100V (12294) 913-3680-000 A24C6	1	
29	805-014X5V0103Z	2	CAPACITOR,FXD CER DIEI, 0.01UF, M20XP80Z, 100V (12294) 913-3680-000 A24C5	1	
30	805-014X5V0103Z	2	CAPACITOR,FXD CER DIEI, 0.01UF, M20XP80Z, 100V (12294) 913-3680-000 A24C1	1	
31	MS75085-07	2	COIL,RF 100UH (96906) 240-2047-000 A24L1	1	
32	MS75085-07	2	COIL,RF 100UH (96906) 240-2047-000 A24L3	1	
33	637-9313-001	2	RIBBON CABLE A24J46	1	
34	MS75085-07	2	COIL,RF 100UH (96906) 240-2047-000 A24L5	1	
35	MS75085-07	2	COIL,RF 100UH (96906) 240-2047-000 A24L8	1	
36	MS75085-07	2	COIL,RF 100UH (96906) 240-2047-000 A24L27	1	
37	MS75085-07	2	COIL,RF 100UH (96906) 240-2047-000 A24L12	1	
38	MS75085-07	2	COIL,RF 100UH (96906) 240-2047-000 A24L14	1	
39	MS75085-07	2	COIL,RF 100UH (96906) 240-2047-000 A24L16	1	
40	MS75085-07	2	COIL,RF 100UH (96906) 240-2047-000 A24L18	1	
41	MS75085-07	2	COIL,RF 100UH (96906) 240-2047-000 A24L20	1	
42	MS75085-07	2	COIL,RF 100UH (96906) 240-2047-000 A24L22	1	
43	MS75085-07	2	COIL,RF 100UH (96906) 240-2047-000 A24L24	1	
44	MS75085-07	2	COIL,RF 100UH (96906) 240-2047-000 A24L26	1	
45	MS75085-07	2	COIL,RF 100UH (96906) 240-2047-000 A24L28	1	
46	MS75085-07	2	COIL,RF 100UH (96906) 240-2047-000 A24L30	1	
47	MS75085-07	2	COIL,RF 100UH (96906) 240-2047-000 A24L32	1	

GROUP ASSEMBLY PARTS LIST

FIG-ITEM	PART NO	INDENT	DESCRIPTION	UNITS PER ASSY	USABLE ON CODE
6-48	805-014X5V0103Z	2	CAPACITOR,FXD CER DIEI, 0.01UF, M20XP80%, 100V (12294) 913-3680-000 A24C32	1	
49	805-014X5V0103Z	2	CAPACITOR,FXD CER DIEI, 0.01UF, M20XP80%, 100V (12294) 913-3680-000 A24C33	1	
50	805-014X5V0103Z	2	CAPACITOR,FXD CER DIEI, 0.01UF, M20XP80%, 100V (12294) 913-3680-000 A24C28	1	
51	805-014X5V0103Z	2	CAPACITOR,FXD CER DIEI, 0.01UF, M20XP80%, 100V (12294) 913-3680-000 A24C29	1	
52	805-014X5V0103Z	2	CAPACITOR,FXD CER DIEI, 0.01UF, M20XP80%, 100V (12294) 913-3680-000 A24C30	1	
53	805-014X5V0103Z	2	CAPACITOR,FXD CER DIEI, 0.01UF, M20XP80%, 100V (12294) 913-3680-000 A24C20	1	
54	805-014X5V0103Z	2	CAPACITOR,FXD CER DIEI, 0.01UF, M20XP80%, 100V (12294) 913-3680-000 A24C22	1	
55	805-014X5V0103Z	2	CAPACITOR,FXD CER DIEI, 0.01UF, M20XP80%, 100V (12294) 913-3680-000 A24C24	1	
56	805-014X5V0103Z	2	CAPACITOR,FXD CER DIEI, 0.01UF, M20XP80%, 100V (12294) 913-3680-000 A24C18	1	
57	805-014X5V0103Z	2	CAPACITOR,FXD CER DIEI, 0.01UF, M20XP80%, 100V (12294) 913-3680-000 A24C16	1	
58	805-014X5V0103Z	2	CAPACITOR,FXD CER DIEI, 0.01UF, M20XP80%, 100V (12294) 913-3680-000 A24C31	1	
59	805-014X5V0103Z	2	CAPACITOR,FXD CER DIEI, 0.01UF, M20XP80%, 100V (12294) 913-3680-000 A24C26	1	
60	805-014X5V0103Z	2	CAPACITOR,FXD CER DIEI, 0.01UF, M20XP80%, 100V (12294) 913-3680-000 A24C27	1	
61	805-014X5V0103Z	2	CAPACITOR,FXD CER DIEI, 0.01UF, M20XP80%, 100V (12294) 913-3680-000 A24C25	1	
62	805-014X5V0103Z	2	CAPACITOR,FXD CER DIEI, 0.01UF, M20XP80%, 100V (12294) 913-3680-000 A24C23	1	
63	805-014X5V0103Z	2	CAPACITOR,FXD CER DIEI, 0.01UF, M20XP80%, 100V (12294) 913-3680-000 A24C21	1	
64	805-014X5V0103Z	2	CAPACITOR,FXD CER DIEI, 0.01UF, M20XP80%, 100V (12294) 913-3680-000 A24C17	1	
65	805-014X5V0103Z	2	CAPACITOR,FXD CER DIEI, 0.01UF, M20XP80%, 100V (12294) 913-3680-000 A24C19	1	
66	MS75085-07	2	COIL,RF 100UH (96906) 240-2047-000 A24L33	1	
67	MS75085-07	2	COIL,RF 100UH (96906) 240-2047-000 A24L31	1	
68	MS75085-07	2	COIL,RF 100UH (96906) 240-2047-000 A24L29	1	
69	DCU37PBF	2	CONNECTOR,PLUG ELEC (71468) 371-0385-090 A24J16	1	
70	4007-4HT	2	TERMINAL,LUG (77147) 304-0015-000	2	

3. NUMERICAL INDEX

PART NUMBER	FIG-ITEM	TTL REQ	PART NUMBER	FIG-ITEM	TTL REQ
AGC250-1	1-82	5	MS35649-244	1-27	
AGC250-2	1-83	5		1-40	
CD5FY151J0	5-5			1-52	
	5-6			1-60	
	5-8			1-72	15
	5-10		MS35650-304	1-29	4
	5-12		MS51957-11	1-70	2
	5-13	6	MS51957-13	1-27	
CK63AW103M	1-54			1-27	
	1-55			1-36	64
	1-56		MS51957-13B	2-41	
	1-57			2-42	12
	1-57A		MS51957-15	1-60	
	1-57B			1-72	5
	1-62		MS51957-18B	2-30	2
	1-63		MS51957-28	1-3	
	1-64			1-33	
	1-65			1-71	23
	1-66		MS51957-29	1-41	
	1-66A			1-51	8
	2-20		MS51957-3	1-17	
	2-22			1-76	
	2-23			4-1	15
	2-25	13	MS51957-3B	2-37	
DCU37PBB	6-15	1		2-39	
DCU37PBF	6-69	1		2-40	
DIE845	4-30	22		2-50	26
F1-15H4	2-38	1	MS51957-30	1-3	
MS25036-144	2-30	7		1-52	
MS25237-327-15	1-84			1-53	
	2-33			1-61	11
	2-34	3	MS51957-5B	2-48	
MS35338-134	1-17			2-49	
	1-76			2-49	13
	2-37		MS51958-61	1-51	2
	2-39		MS51959-12	2-2	2
	2-40		MS75085-07	5-2	
	2-48			5-3	
	2-49			5-18	
	2-49			5-19	
	2-50			5-20	
	4-1	41		5-21	
MS35338-135	1-27			5-22	
	1-36			5-23	
	1-52			5-24	
	1-60			5-25	
	1-72			5-26	
	2-30			5-27	
	2-41			5-28	
	2-42	45		5-29	
MS35338-138	1-29	4		5-30	
MS35338-97	4-30	22		5-31	
MS35338-99	1-75	1		5-32	
MS35649-224	2-48			5-33	
	2-49			5-34	
	2-49	13		5-35	

NUMERICAL INDEX

PART NUMBER	FIG-ITEM	TTL REQ	PART NUMBER	FIG-ITEM	TTL REQ	
MS75085-07	5-36		M641-6-1	2-26	2	
	5-37		NE15F01-0003-00	2-39	1	
	5-38		P312-0116-000	1-29	4	
	5-39		P313-0045-000	1-33		
	5-40			1-41		
	5-41			1-53		
	5-42			1-61		
	5-43			1-71	17	
	5-44			2-30	5	
	5-45			P313-0051-000	2-3	
	5-46			P313-0064-000	2-5	
	5-47				2-7	
	5-48				2-16	
	5-49				2-18	5
	5-50			P313-0132-000	2-2	2
	5-51			P313-0156-00	4-30	22
	5-52			P325-0051-000	1-78	2
	5-53			P343-0285-000	2-30	1
	5-54			P343-0289-000	4-30	22
	5-55			P343-0291-000	2-35	3
	5-56			P343-0311-000	1-75	1
	5-57			P500	1-69	
	5-58				1-69	6
	6-1			RB67-1-0ML9	2-18	1
	6-2			RB67-1DCML	2-3	
	6-3				2-5	
	6-4				2-7	
	6-5				2-16	4
	6-6			RCR07G104KS	3-6	1
	6-7			RCR07G105KS	3-5	1
	6-8			RCR07G223KS	3-42	
	6-9				3-45	2
	6-10			RCR07G271KS	3-1	
	6-11				3-3	
	6-12				3-29	
	6-13				3-30	
	6-14				3-35	
	6-31				3-37	
	6-32				3-39	
	6-34				3-40	
	6-35				3-41	
	6-36				3-43	
	6-37				3-44	11
	6-38			RG178BU	1-39	AR
	6-39				1-45	AR
	6-40				4-6	AR
	6-41				4-9	AR
	6-42				4-12	AR
	6-43				4-17	AR
	6-44				4-20	AR
	6-45			RN55D1540F	3-28	1
	6-46			RN55D16R9F	3-27	1
	6-47			024-0057-000	1-85	1
	6-66			024-0058-000	1-86	1
	6-67			025-0250	1-32	8
	6-68	76		055-905-0069	1-46	2
	MS75089-11	5-1	1	091-0071-000	5-70	10
	M153SBRTTIN	5-72	8	1-480426-0	2-28	1
	M24308-26-1	1-73		1N4454GE	3-2	
		1-73	16		3-4	
	M39012-25-0006	1-41	1		3-8	
	M641-5-1	2-24	1		3-9	
	M641-6-1	2-21			3-10	



NUMERICAL INDEX

PART NUMBER	FIG-ITEM	TTL REQ	PART NUMBER	FIG-ITEM	TTL REQ
1N4454GE	3-11		240-2047-000	5-34	
	3-12			5-35	
	3-13			5-36	
	3-15			5-37	
	3-16			5-38	
	3-17			5-39	
	3-18			5-40	
	3-19			5-41	
	3-20			5-42	
	3-21			5-43	
	3-22			5-44	
	3-23			5-45	
	3-24			5-46	
	3-25			5-47	
	3-26			5-48	
	3-31			5-49	
	3-32			5-50	
	3-33			5-51	
	3-34			5-52	
	3-36			5-53	
	3-38	26		5-54	
115-0260-003	1-35	4		5-55	
12-954	1-49	AR		5-56	
150-0810-040	1-28	16		5-57	
150-0873-010	1-32	8		5-58	
150-1012-030	1-35	4		6-1	
17250	1-77	1		6-2	
184-9102-090	5-4			6-3	
	5-7			6-4	
	5-9			6-5	
	5-11			6-6	
	5-14			6-7	
	5-17	6		6-8	
184-9102-260	5-15	1		6-9	
184-9102-830	5-16	1		6-10	
199D1009	5-15	1		6-11	
199D336X0010DB1	5-4			6-12	
	5-7			6-13	
	5-9			6-14	
	5-11			6-31	
	5-14			6-32	
	5-17	6		6-34	
199D475X0035DE3	5-16	1		6-35	
201-0088-000	4-29	2		6-36	
23071-4	1-28	16		6-37	
240-2047-000	5-2			6-38	
	5-3			6-39	
	5-18			6-40	
	5-19			6-41	
	5-20			6-42	
	5-21			6-43	
	5-22			6-44	
	5-23			6-45	
	5-24			6-46	
	5-25			6-47	
	5-26			6-66	
	5-27			6-67	
	5-28			6-68	76
	5-29		240-2715-370	5-1	1
	5-30		259-7201-070	2-8	1
	5-31		259-7201-080	2-6	1
	5-32		259-7201-220	2-17	1
	5-33		259-7201-230	2-4	1

NUMERICAL INDEX

PART NUMBER	FIG-ITEM	TTL REQ	PART NUMBER	FIG-ITEM	TTL REQ
259-8017-040	2-19	1	310-0279-000	1-27	
262-1106-000	1-84			1-36	
	2-33			1-52	
	2-34	3		1-60	
264-0721-000	1-82	5		1-72	
264-0723-000	1-83	5		2-30	
266-5415-120	2-9			2-41	
	2-10			2-42	45
	2-12	3	310-0284-000	1-29	4
266-5415-130	2-13		310-0460-000	4-30	22
	2-14	2	310-6340-000	1-36	
266-5415-150	2-11	1		1-40	
266-5415-170	2-15	1		1-41	
266-7508-210	2-38	1		2-30	
266-7524-010	2-39	1		2-37	16
280-1368-350	1-1	1	312-0116-000	1-29	4
280-2745-020	1-80	1	313-0019-000	1-29	4
280430BF1	2-8	1	313-0037-000	2-48	
280442BF1	2-6	1		2-49	
280545BF1	2-17	1		2-49	13
280551BF1	2-4	1	313-0043-000	1-27	
281-0650-010	2-3			1-40	
	2-5			1-52	
	2-7			1-60	
	2-16	4		1-72	15
281-0650-030	2-18	1	313-0045-000	1-33	
3VN10-1CDD3	5-60			1-41	
	5-61			1-53	
	5-62			1-61	
	5-63			1-71	17
	5-64		313-0051-000	2-30	5
	5-65		313-0064-000	2-3	
	5-66			2-5	
	5-67			2-7	
	5-68			2-16	
	5-69	10		2-18	5
304-0015-000	4-3		313-0132-000	2-2	2
	6-70	3	313-0156-000	4-30	22
304-1089-000	1-52		325-0051-000	1-78	2
	1-58		340-1010-000	2-35	1
	1-67	4	342-0043-000	2-2	2
304-1251-000	2-30	7	343-0019-000	2-41	
307-1270-000	5-72	8		2-42	12
308-0312-020	1-69		343-0024-000	2-30	2
	1-69	6	343-0072-000	2-37	
310-0057-000	1-75	1		2-39	
310-0071-000	1-33			2-40	
	1-41			2-50	26
	1-53		343-0124-000	1-17	
	1-61			1-76	
	1-71	17		4-1	15
310-0095-000	4-30	22	343-0131-000	1-70	2
310-0098-000	1-75	1	343-0133-000	1-27	
310-0275-000	1-17			1-27	
	1-76			1-36	64
	2-37		343-0135-000	1-60	
	2-39			1-72	5
	2-40		343-0169-000	1-3	
	2-48			1-33	
	2-49			1-71	23
	2-49		343-0170-000	1-41	
	2-50			1-51	8
	4-1	41	343-0171-000	1-3	

NUMERICAL INDEX

PART NUMBER	FIG-ITEM	TTL REQ	PART NUMBER	FIG-ITEM	TTL REQ
343-0171-000	1-52		371-0062-000	1-73	16
	1-53		371-0385-090	6-15	
	1-61	11		6-69	2
343-0226-000	1-51	2	372-0043-410	3-7	1
343-0285-000	2-30	1	372-0043-530	3-14	
343-0289-000	4-30	22		5-59	2
343-0291-000	2-35	3	372-2601-012	5-71	8
343-0311-000	1-75	1	372-5884-200	2-27	4
343-0674-000	2-48		372-5884-480	2-28	1
	2-49		372-7086-010	5-60	
	2-49	13		5-61	
353-18-10-001	1-59			5-62	
	1-68	2		5-63	
353-3644-010	3-2			5-64	
	3-4			5-65	
	3-8			5-66	
	3-9			5-67	
	3-10			5-68	
	3-11			5-69	10
	3-12		372-7600-270	5-70	10
	3-13		4007-4HT	4-3	
	3-15			6-70	3
	3-16		403	1-52	
	3-17			1-58	
	3-18			1-67	4
	3-19		425-0217-010	1-49	AR
	3-20		425-1528-000	4-23	AR
	3-21			4-28	AR
	3-22		425-1538-000	1-39	AR
	3-23			1-45	AR
	3-24			4-6	AR
	3-25			4-9	AR
	3-26			4-12	AR
	3-31			4-17	AR
	3-32			4-20	AR
	3-33		426-1034-010	1-77	1
	3-34		450-0151-010	2-35	1
	3-36		51-071-0019	1-48	2
	3-38	26	51-330-3188	1-47	2
357-7129-010	1-40	1	52-312-9040	1-43	
357-7207-220	1-43			1-44	
	1-44			4-4	
	4-4			4-5	
	4-5			4-15	
	4-15			4-16	
	4-16			4-26	
	4-26			4-27	8
	4-27	8	52-312-9094	1-38	
357-7207-320	1-38			4-8	
	4-8			4-11	
	4-11			4-19	
	4-19			4-22	5
	4-22	5	540-9006-003	1-76	
357-7374-010	1-47	2		2-39	
357-7533-010	1-48	2		2-50	8
357-8985-020	1-46	2	540-9039-003	1-36	8
357-9069-000	1-41	1	540-9096-003	2-40	3
358-1040-000	2-21		541-6106-002	1-29	4
	2-26	2	60618-1	2-27	4
358-1050-000	2-24	1	622-3460-001	1-4	1
367-0018-000	1-59		622-3472-001	1-	1
	1-68	2	622-3473-001	1-	1
371-0062-000	1-73		622-3473-002	1-	1

NUMERICAL INDEX

PART NUMBER	FIG-ITEM	TTL REQ	PART NUMBER	FIG-ITEM	TTL REQ
622-3473-003	1-	1	637-1781-006	2-36	1
622-3473-004	1-	1	637-2712-001	1-76	1
622-3499-001	1-5	1		6-	REF
623-1379-001	1-50		637-9121-001	1-78	1
	4-2		637-9295-001	1-79	1
	4-13		637-9313-001	6-33	1
	4-24	17	638-6476-001	1-15	1
623-2080-001	1-24	1	638-6476-003	1-16	1
623-2080-002	1-23	1	638-6597-001	2-47	1
623-2080-003	1-22	1		3-	REF
623-9008-001	2-1	1	638-6622-001	1-9	1
630-2189-001	1-35	1	638-6636-001	1-12	1
632-5201-001	2-2	1	638-6636-002	1-11	1
634-8176-001	1-27	2	638-6636-003	1-10	1
634-8177-001	1-87	1	638-6659-001	1-13	1
634-8178-001	4-31	1	638-6896-001	1-6	1
634-8179-001	1-3	1	638-6962-001	1-19	1
634-8180-002	1-2	1	638-6973-001	4-30	1
634-8181-002	1-2	1		5-	REF
634-8186-001	4-1	1	642-0020-000	1-70	1
634-8189-001	2-43	1	642-0022-000	1-70	1
634-8191-001	1-31	1	642-2407-001	1-61	1
634-8192-001	1-31	1	642-2408-001	1-53	1
634-8199-001	1-30	1	642-2409-001	1-17	1
	2-	REF	642-2451-001	1-20	1
634-8199-002	1-30	1	642-2454-001	1-46	1
	2-	REF	642-2455-001	1-34	1
634-8201-001	1-33	1	642-3135-001	1-8	1
	4-	REF	642-3137-001	1-7	1
634-8211-001	1-36	1	7-50-60	4-29	2
634-8219-001	1-72	1	705-0911-000	3-27	1
634-8273-001	2-49	1	705-0957-000	3-28	1
634-8289-001	2-35A	1	7101P3PD9V40B	2-13	
635-0656-001	1-18			2-14	2
635-0657-001	1-21	1	7103P3PD9V40B	2-9	
635-0825-012	2-50	1		2-10	
635-0830-001	2-48	1		2-12	3
635-4930-001	1-25	1	7203P3PD9V40B	2-11	1
635-4930-002	1-25	1	7207P3PD9V40B	2-15	1
635-9601-001	2-41	1	745-0728-000	3-1	
635-9602-001	2-51	1		3-3	
635-9603-001	2-46	1		3-29	
635-9611-003	1-51	1		3-30	
635-9614-001	2-32	1		3-35	
635-9615-001	2-42	1		3-37	
635-9616-001	1-29	2		3-39	
635-9625-006	2-45	1		3-40	
635-9649-001	1-26	1		3-41	
635-9696-001	2-49	1		3-43	
635-9699-001	1-71	1		3-44	11
637-1525-004	1-37	1	745-0797-000	3-42	
637-1526-003	1-42			3-45	2
	4-3		745-0821-000	3-6	1
	4-25	3	745-0857-000	3-5	1
637-1526-006	4-14	1	7521	2-35	1
637-1529-001	4-7		801-B3800B75	1-40	1
	4-10		805-014X5V0103Z	6-16	
	4-18			6-17	
	4-21	4		6-18	
637-1546-001	2-37	2		6-19	
637-1547-001	2-52	1		6-20	
637-1768-002	1-14	1		6-21	
637-1769-001	1-81	1		6-22	
637-1779-001	2-31	1			

NUMERICAL INDEX

PART NUMBER	FIG-ITEM	TTL REQ	PART NUMBER	FIG-ITEM	TTL REQ
805-014X5V0103Z	6-23		913-3680-000	6-28	
	6-24			6-29	
	6-25			6-30	
	6-26			6-48	
	6-27			6-49	
	6-28			6-50	
	6-29			6-51	
	6-30			6-52	
	6-48			6-53	
	6-49			6-54	
	6-50			6-55	
	6-51			6-56	
	6-52			6-57	
	6-53			6-58	
	6-54			6-59	
	6-55			6-60	
	6-56			6-61	
	6-57			6-62	
	6-58			6-63	
	6-59			6-64	
	6-60			6-65	
	6-61				33
	6-62				
	6-63				
	6-64				
	6-65	33			
	87478-4	3-7		1	
87478-8	3-14				
	5-59	2			
912-4141-400	5-5				
	5-6				
	5-8				
	5-10				
	5-12				
	5-13	6			
913-1188-000	1-54				
	1-55				
	1-56				
	1-57				
	1-57A				
	1-57B				
	1-62				
	1-63				
	1-64				
	1-65				
	1-66				
	1-66A				
	2-20				
	2-22				
	2-23				
	2-25	13			
913-3680-000	6-16				
	6-17				
	6-18				
	6-19				
	6-20				
	6-21				
	6-22				
	6-23				
	6-24				
	6-25				
	6-26				
	6-27				

4. REFERENCE DESIGNATION INDEX

REFERENCE DESIGNATION	FIG-ITEM	PART NUMBER	REFERENCE DESIGNATION	FIG-ITEM	PART NUMBER
A1	1-26	635-9649-001	A2A2R5	3-41	RCR07G271KS
A10	1-9	638-6622-001	A2A2R6	3-43	RCR07G271KS
A11	1-8	642-3135-001	A2A2R7	3-44	RCR07G271KS
A12	1-7	642-3137-001	A2A2R8	3-45	RCR07G223KS
A13	1-6	638-6896-001	A2A2R9	3-3	RCR07G271KS
A14	1-18	635-0656-001	A2A3	2-48	635-0830-001
A15	1-19	638-6962-001	A2A5	2-36	637-1781-006
A16	1-20	642-2451-001	A2C1	2-25	CK63AW103M
A19	1-21	635-0657-001	A2C2	2-20	CK63AW103M
A2	1-30	634-8199-001	A2C3	2-22	CK63AW103M
A2	1-30	634-8199-002	A2C4	2-23	CK63AW103M
A2	2-	634-8199-001	A2DS1	2-33	MS25237-327-15
A2	2-	634-8199-002	A2DS2	2-34	MS25237-327-15
A2A1	2-50	635-0825-012	A2J1	2-26	M641-6-1
A2A2	2-47	638-6597-001	A2J2	2-21	M641-6-1
A2A2	3-	638-6597-001	A2J3	2-24	M641-5-1
A2A2CR1	3-26	1N4454GE	A2M1	2-35	7521
A2A2CR10	3-13	1N4454GE	A2P1	2-28	1-480426-0
A2A2CR11	3-12	1N4454GE	A2S1	2-4	280551BF1
A2A2CR12	3-11	1N4454GE	A2S10	2-17	280545BF1
A2A2CR13	3-10	1N4454GE	A2S11	2-19	259-8017-040
A2A2CR14	3-9	1N4454GE	A2S12	2-15	7207P3PD9V40B
A2A2CR15	3-8	1N4454GE	A2S15	2-39	NE15F01-0003-00
A2A2CR16	3-4	1N4454GE	A2S2	2-6	280442BF1
A2A2CR17	3-2	1N4454GE	A2S3	2-8	280430BF1
A2A2CR19	3-38	1N4454GE	A2S4	2-9	7103P3PD9V40B
A2A2CR2	3-25	1N4454GE	A2S5	2-10	7103P3PD9V40B
A2A2CR24	3-33	1N4454GE	A2S6	2-11	7203P3PD9V40B
A2A2CR25	3-21	1N4454GE	A2S7	2-12	7103P3PD9V40B
A2A2CR26	3-20	1N4454GE	A2S8	2-13	7101P3PD9V40B
A2A2CR27	3-34	1N4454GE	A2S9	2-14	7101P3PD9V40B
A2A2CR28	3-22	1N4454GE	A2W1	2-35A	634-8289-001
A2A2CR29	3-23	1N4454GE	A20	1-22	623-2080-003
A2A2CR3	3-24	1N4454GE	A21	1-23	623-2080-002
A2A2CR30	3-31	1N4454GE	A22	1-24	623-2080-001
A2A2CR31	3-32	1N4454GE	A23	1-25	635-4930-001
A2A2CR4	3-19	1N4454GE	A23	1-25	635-4930-002
A2A2CR5	3-18	1N4454GE	A24	1-76	637-2712-001
A2A2CR6	3-17	1N4454GE	A24	6-	637-2712-001
A2A2CR7	3-36	1N4454GE	A24C1	6-30	805-014X5V0103Z
A2A2CR8	3-16	1N4454GE	A24C10	6-24	805-014X5V0103Z
A2A2CR9	3-15	1N4454GE	A24C11	6-19	805-014X5V0103Z
A2A2J1	3-7	87478-4	A24C12	6-25	805-014X5V0103Z
A2A2J2	3-14	87478-8	A24C13	6-18	805-014X5V0103Z
A2A2R1	3-28	RN5501540F	A24C14	6-16	805-014X5V0103Z
A2A2R10	3-1	RCR07G271KS	A24C15	6-17	805-014X5V0103Z
A2A2R11	3-29	RCR07G271KS	A24C16	6-57	805-014X5V0103Z
A2A2R12	3-30	RCR07G271KS	A24C17	6-64	805-014X5V0103Z
A2A2R14	3-42	RCR07G223KS	A24C18	6-56	805-014X5V0103Z
A2A2R15	3-39	RCR07G271KS	A24C19	6-65	805-014X5V0103Z
A2A2R19	3-5	RCR07G105KS	A24C2	6-21	805-014X5V0103Z
A2A2R2	3-35	RCR07G271KS	A24C20	6-53	805-014X5V0103Z
A2A2R20	3-6	RCR07G104KS	A24C21	6-63	805-014X5V0103Z
A2A2R21	3-27	RN55016R9F	A24C22	6-54	805-014X5V0103Z
A2A2R3	3-37	RCR07G271KS	A24C23	6-62	805-014X5V0103Z
A2A2R4	3-40	RCR07G271KS	A24C24	6-55	805-014X5V0103Z

## REFERENCE DESIGNATION INDEX

REFERENCE DESIGNATION	FIG-ITEM	PART NUMBER	REFERENCE DESIGNATION	FIG-ITEM	PART NUMBER
A24C25	6-61	805-014X5V0103Z	A27C4	5-9	199D336X0010DB1
A24C26	6-59	805-014X5V0103Z	A27C5	5-7	199D336X0010DB1
A24C27	6-60	805-014X5V0103Z	A27C6	5-16	199D475X0035DE3
A24C28	6-50	805-014X5V0103Z	A27C7	5-13	CD5FY151J0
A24C29	6-51	805-014X5V0103Z	A27C8	5-12	CD5FY151J0
A24C3	6-27	805-014X5V0103Z	A27C9	5-10	CD5FY151J0
A24C30	6-52	805-014X5V0103Z	A27J1	5-69	3VN10-1CDD3
A24C31	6-58	805-014X5V0103Z	A27J10	5-60	3VN10-1CDD3
A24C32	6-48	805-014X5V0103Z	A27J11	5-59	87478-8
A24C33	6-49	805-014X5V0103Z	A27J2	5-68	3VN10-1CDD3
A24C4	6-26	805-014X5V0103Z	A27J24	4-27	52-312-9040
A24C5	6-29	805-014X5V0103Z	A27J28	4-5	52-312-9040
A24C6	6-28	805-014X5V0103Z	A27J3	5-67	3VN10-1CDD3
A24C7	6-22	805-014X5V0103Z	A27J32	4-15	52-312-9040
A24C8	6-23	805-014X5V0103Z	A27J34	4-11	52-312-9094
A24C9	6-20	805-014X5V0103Z	A27J39	4-8	52-312-9094
A24J15	6-15	DCU37PBB	A27J4	5-66	3VN10-1CDD3
A24J16	6-69	DCU37PBF	A27J43	4-26	52-312-9040
A24J46	6-33	637-9313-001	A27J44	4-16	52-312-9040
A24L1	6-31	MS75085-07	A27J45	4-4	52-312-9040
A24L10	6-13	MS75085-07	A27J5	5-65	3VN10-1CDD3
A24L11	6-8	MS75085-07	A27J54	4-22	52-312-9094
A24L12	6-37	MS75085-07	A27J55	4-19	52-312-9094
A24L13	6-7	MS75085-07	A27J6	5-64	3VN10-1CDD3
A24L14	6-38	MS75085-07	A27J7	5-63	3VN10-1CDD3
A24L15	6-6	MS75085-07	A27J8	5-62	3VN10-1CDD3
A24L16	6-39	MS75085-07	A27J9	5-61	3VN10-1CDD3
A24L17	6-5	MS75085-07	A27L1	5-18	MS75085-07
A24L18	6-40	MS75085-07	A27L10	5-27	MS75085-07
A24L19	6-4	MS75085-07	A27L11	5-28	MS75085-07
A24L2	6-14	MS75085-07	A27L12	5-29	MS75085-07
A24L20	6-41	MS75085-07	A27L13	5-30	MS75085-07
A24L21	6-3	MS75085-07	A27L14	5-31	MS75085-07
A24L22	6-42	MS75085-07	A27L15	5-32	MS75085-07
A24L23	6-2	MS75085-07	A27L16	5-33	MS75085-07
A24L24	6-43	MS75085-07	A27L17	5-34	MS75085-07
A24L25	6-1	MS75085-07	A27L18	5-35	MS75085-07
A24L26	6-44	MS75085-07	A27L19	5-36	MS75085-07
A24L27	6-36	MS75085-07	A27L2	5-19	MS75085-07
A24L28	6-45	MS75085-07	A27L20	5-37	MS75085-07
A24L29	6-68	MS75085-07	A27L21	5-38	MS75085-07
A24L3	6-32	MS75085-07	A27L22	5-39	MS75085-07
A24L30	6-46	MS75085-07	A27L23	5-40	MS75085-07
A24L31	6-67	MS75085-07	A27L24	5-41	MS75085-07
A24L32	6-47	MS75085-07	A27L25	5-42	MS75085-07
A24L33	6-66	MS75085-07	A27L26	5-43	MS75085-07
A24L4	6-12	MS75085-07	A27L27	5-44	MS75085-07
A24L5	6-34	MS75085-07	A27L28	5-45	MS75085-07
A24L6	6-11	MS75085-07	A27L29	5-46	MS75085-07
A24L7	6-10	MS75085-07	A27L3	5-20	MS75085-07
A24L8	6-35	MS75085-07	A27L30	5-47	MS75085-07
A24L9	6-9	MS75085-07	A27L31	5-48	MS75085-07
A25	1-36	634-8211-001	A27L32	5-49	MS75085-07
A27	1-33	634-8201-001	A27L33	5-50	MS75085-07
A27	4-	634-8201-001	A27L34	5-51	MS75085-07
A27C1	5-4	199D336X0010DB1	A27L35	5-52	MS75085-07
A27C10	5-8	CD5FY151J0	A27L36	5-53	MS75085-07
A27C11	5-6	CD5FY151J0	A27L37	5-54	MS75085-07
A27C12	5-5	CD5FY151J0	A27L38	5-55	MS75085-07
A27C13	5-15	199D1009	A27L39	5-56	MS75085-07
A27C14	5-17	199D336X0010DB1	A27L4	5-21	MS75085-07
A27C2	5-14	199D336X0010DB1	A27L40	5-57	MS75085-07
A27C3	5-11	199D336X0010DB1	A27L41	5-58	MS75085-07

REFERENCE DESIGNATION INDEX

REFERENCE DESIGNATION	FIG-ITEM	PART NUMBER	REFERENCE DESIGNATION	FIG-ITEM	PART NUMBER
A27L42	5-2	MS75085-07			
A27L43	5-3	MS75085-07			
A27L44	5-1	MS75089-11			
A27L5	5-22	MS75085-07			
A27L6	5-23	MS75085-07			
A27L7	5-24	MS75085-07			
A27L8	5-25	MS75085-07			
A27L9	5-26	MS75085-07			
A3	1-16	638-6476-003			
A4	1-15	638-6476-001			
A5	1-10	638-6636-003			
A6	1-11	638-6636-002			
A7	1-12	638-6636-001			
A8	1-13	638-6659-001			
A9	1-14	637-1768-002			
C34	1-57	CK63AW103M			
C35	1-55	CK63AW103M			
C36	1-56	CK63AW103M			
C37	1-54	CK63AW103M			
C38	1-57A	CK63AW103M			
C39	1-57B	CK63AW103M			
C43	1-66	CK63AW103M			
C44	1-65	CK63AW103M			
C45	1-64	CK63AW103M			
C46	1-62	CK63AW103M			
C47	1-63	CK63AW103M			
C48	1-66A	CK63AW103M			
J22	1-40	801-B3800B75			
J50	1-47	51-330-3188			
J51	1-48	51-071-0019			
J52	1-48	51-071-0019			
J53	1-47	51-330-3188			
TB1	1-59	353-18-10-001			
TB2	1-68	353-18-10-001			



# HF-8014( ) Exciter



Rockwell  
International

diagrams

Collins Telecommunications Products Division

523-0770727-001218

1 January 1981

Printed in USA

## list of illustrations

<i>Figure</i>		<i>Page</i>
1	Chassis, Main Sideboard and Ribbon Cabling, Schematic Diagram .....	3
2	Front Panel Assembly A2 (634-8199-XXX), Schematic Diagram .....	17
3	Synthesizer Chassis A27 (634-8201-001) .....	29
4	HF-8014( ) Exciter, Cabling, Connector Layout, and Pin Numbering .....	33
5	Switch Mounting Board A2A2, Layout and Pin Numbering .....	35
6	Remote Control Word Format and Pin Assignment .....	37



## 1. CONFIGURATION STATUS CONTROL

Collins Telecommunications Products Division of Rockwell International uses a 2-character (maximum) alphabetic identifier for configuration identification. The alphabetic identifier is preceded by the letters REV (revision) and starts with dash (—) if no changes have been made. The first change is identified as A, second as B, continuing through Z to AA, AB, and ultimately to ZZ.

**Note**

The alphabetic identifier is not a serial number; therefore, many units or subassemblies may exist with the same identifier.

Incorporation of design changes in a unit or subassembly that has been returned to Rockwell-Collins for repair or that has been removed from the company's finished goods inventory is defined as rework. At the time of rework, the unit or subassembly is marked again to reflect the design level to which it is being upgraded. This is done by leaving the original marking on the unit or subassembly and adding the letters RWK (rework) followed by the alphabetic identifier of the latest change incorporated in the rework. For example, unit one is marked REV B-RWK F and unit two is marked REV F indicating that both units are at the design level of revision F, but unit one is reworked and they may not look exactly the same.

**Note**

A reworked unit may not contain all design changes made prior to the reworked alphabetic identifier, but does contain all changes required to make unit operation identical to a newly manufactured unit with the same alphabetic identifier. Therefore, a unit reworked to a specific alphabetic identifier may physically appear different than a newly manufactured unit of the same alphabetic identifier.

Only alphabetic identifiers that result in schematic changes are covered in this section. Therefore, if a

unit or subassembly has an identifier that alphabetically falls between identifiers on the schematic changes page, or after the last identifier on the schematic changes page up to and including the latest effectivity listed below, the electrical configuration is represented by the earlier alphabetic identifier listed on the schematic changes page.

## 2. CONFIGURATION EFFECTIVITY

Refer to the schematic changes page preceding each subassembly schematic for any subassembly changes that may have occurred and the corresponding alphabetic identifier covering each change.

**Note**

Configuration history before 1 January 1981 is not recorded in this section.

Listed below are the units/subassemblies with the latest alphabetic identifier covered by this document.

<u>UNIT/SUBASSEMBLY</u>	<u>PART NUMBER</u>	<u>LATEST EFFECTIVITY</u>
HF-8014 Exciter	622-3472-001	REV A
HF-8014A Exciter	622-3473-001	REV F
HF-8014A Exciter	622-3473-002	REV F
HF-8014A Exciter	622-3473-003	REV F
HF-8014A Exciter	622-3473-004	REV F
Front Panel Assembly A2	634-8199-001	REV C
Front Panel Assembly A2	634-8199-002	REV C
Mounting Board A2A2	638-6597-001	REV E
Frequency Switchboard A2A3	635-0830-001	REV H
RFI Filter Board A24	637-2712-001	REV M
Synthesizer Output A23	635-4930-002	REV G

***SCHEMATIC CHANGES***

REVISION IDENTIFICATION	DESCRIPTION OF REVISION AND REASON FOR CHANGE	SERVICE BULLETIN	EFFECTIVITY
	<p>(This page will contain schematic revision information.)</p>		

*Chassis, Main Sideboard and Ribbon Cabling, Schematic Diagram  
Figure 1 (Sheet A)*

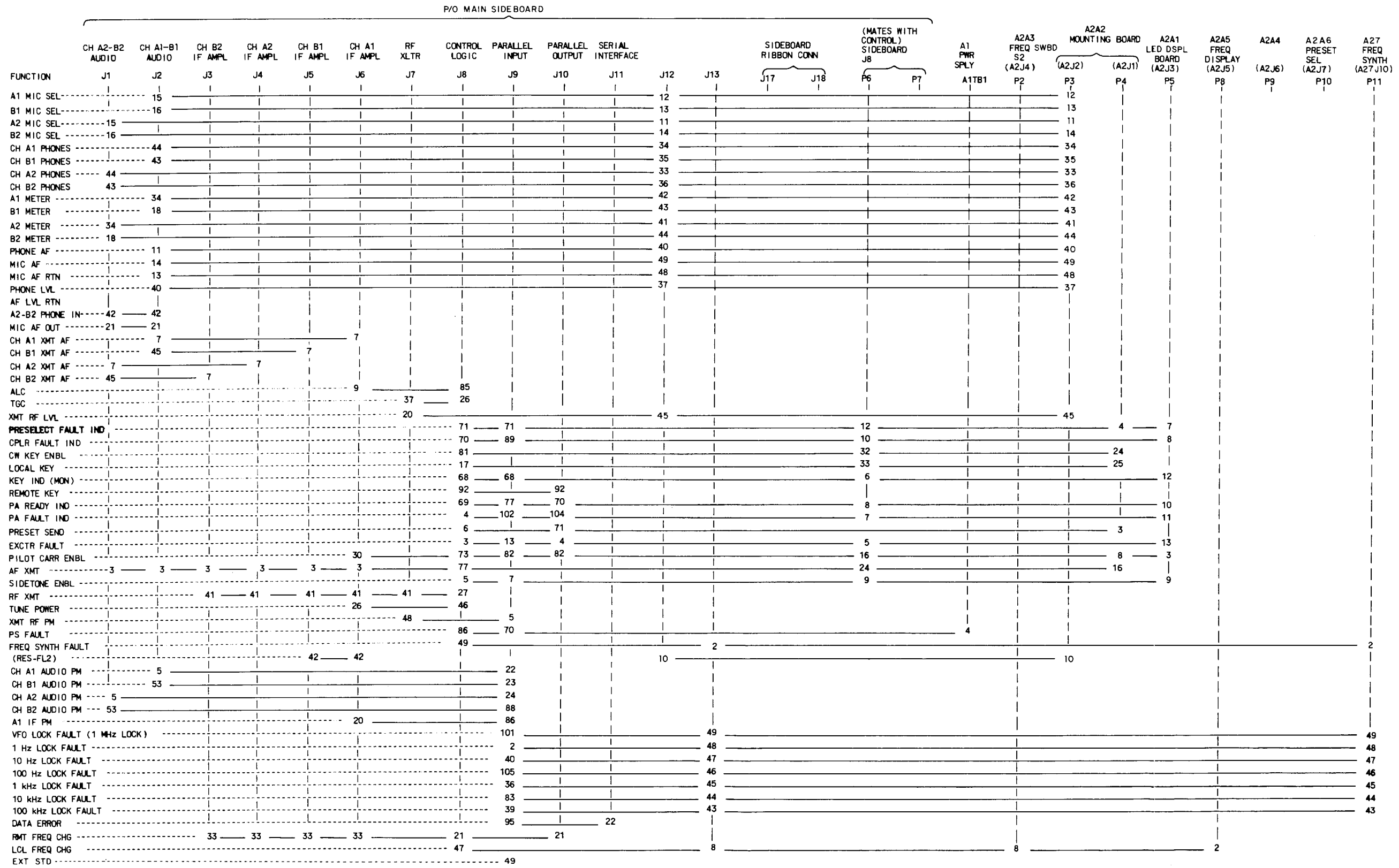

Chassis, Main Sideboard and Ribbon Cabling,  
Schematic Diagram  
Figure 1 (Sheet 1 of 6)

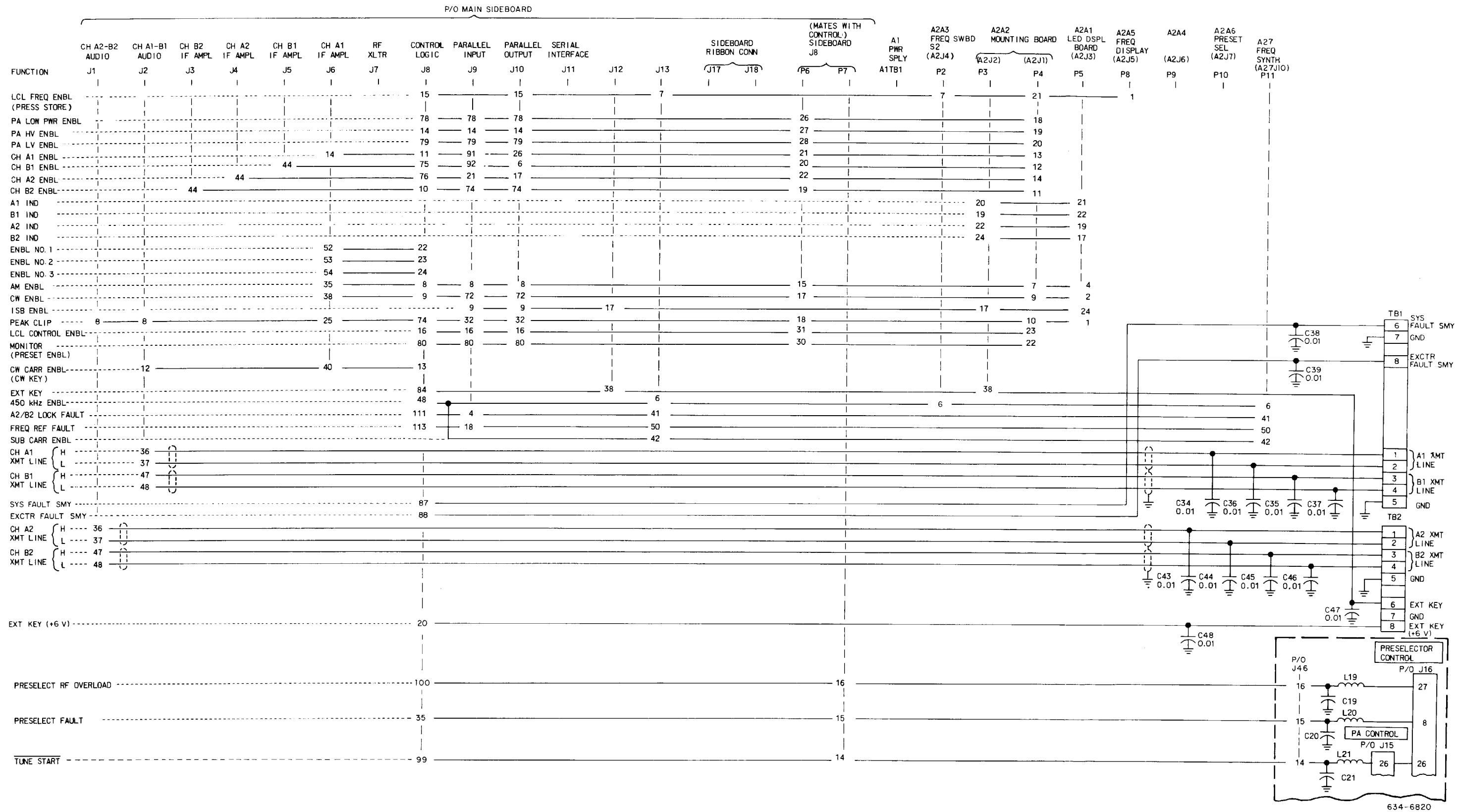

Chassis, Main Sideboard and Ribbon Cabling, Schematic Diagram Figure 1 (Sheet 2)

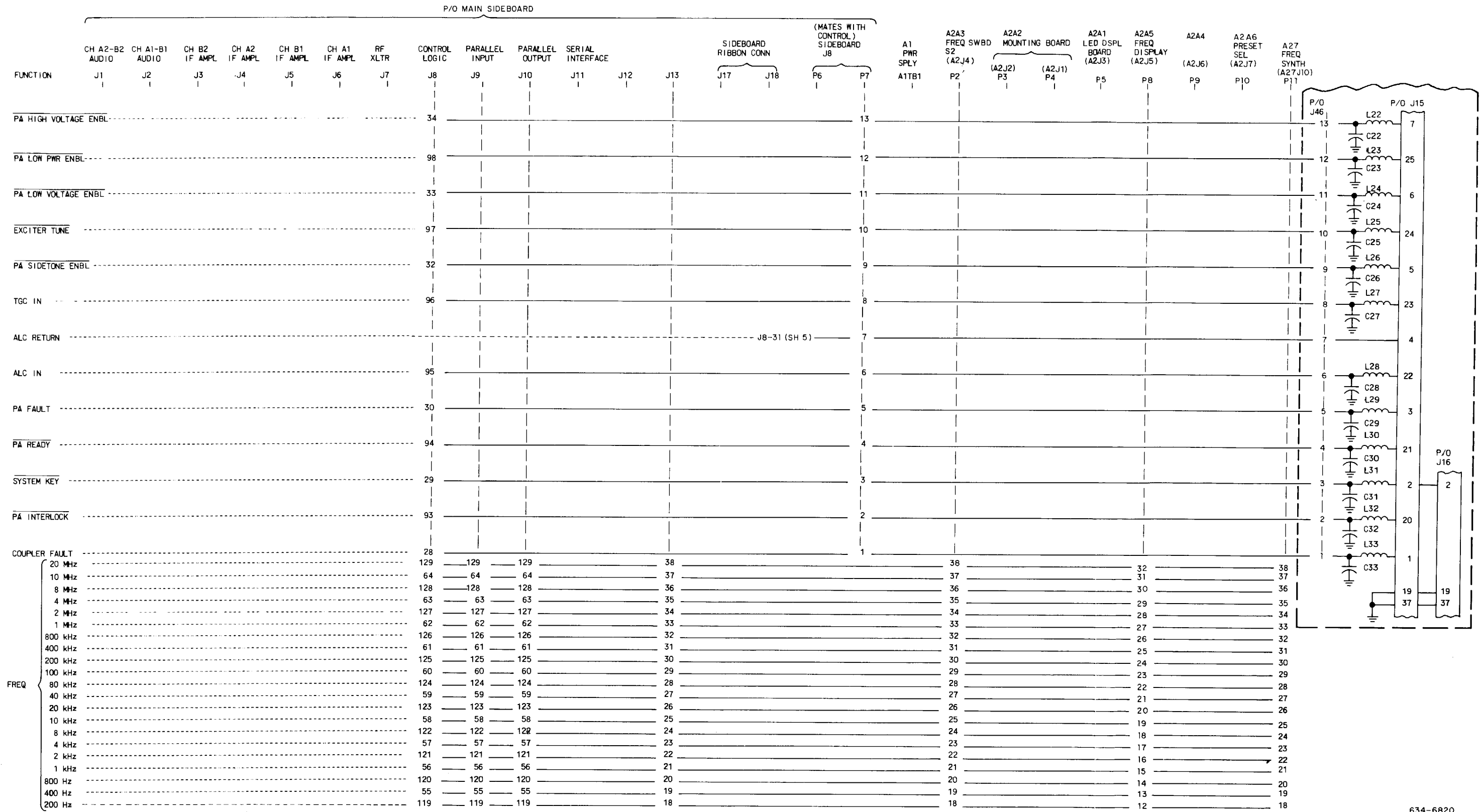

634-6820

Chassis, Main Sideboard and Ribbon Cabling, Schematic Diagram Figure 1 (Sheet 3)

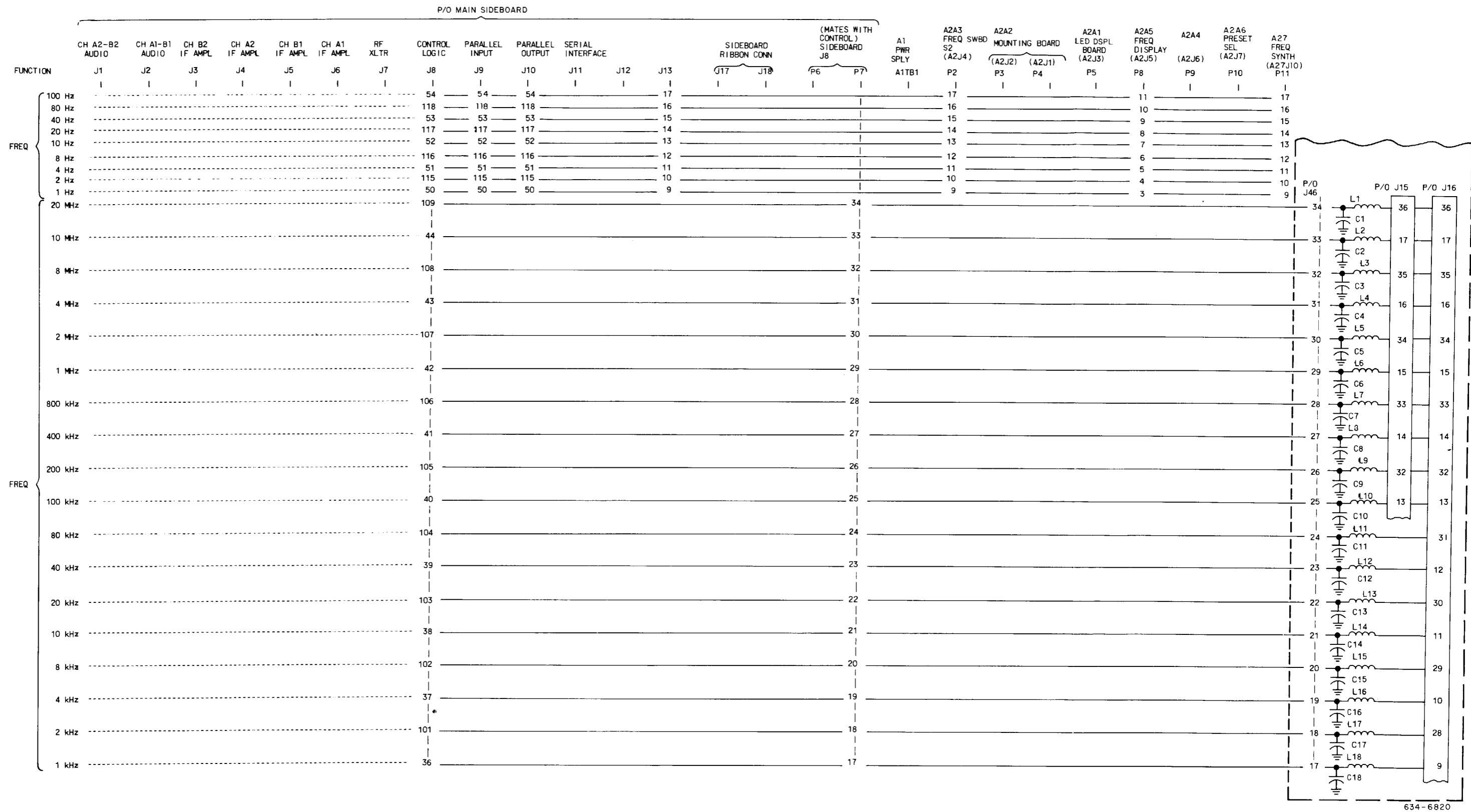

Chassis, Main Sideboard and Ribbon Cabling.  
Schematic Diagram  
Figure 1 (Sheet 4)



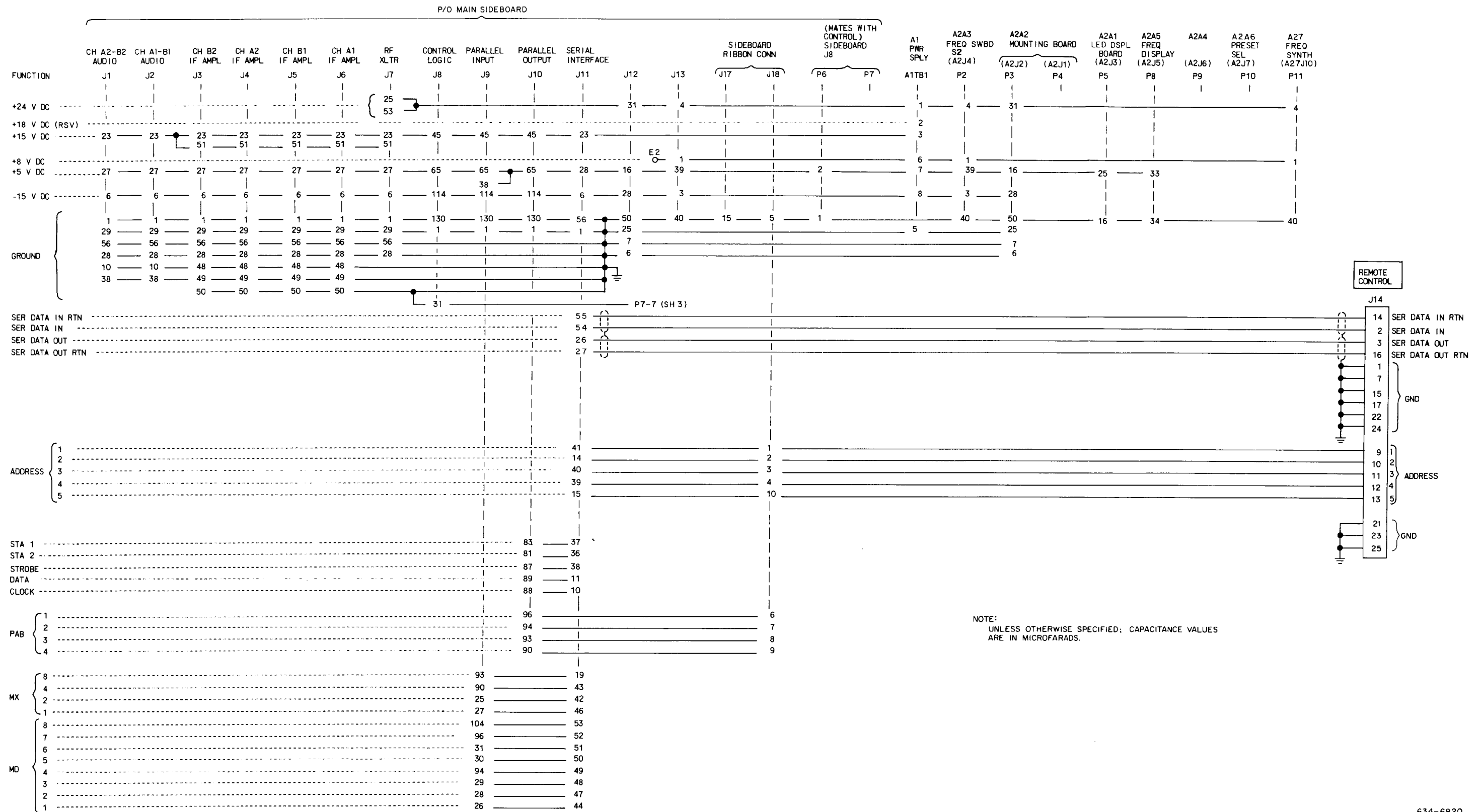

634-6820

Chassis, Main Sideboard and Ribbon Cabling,  
Schematic Diagram  
Figure 1 (Sheet 5)

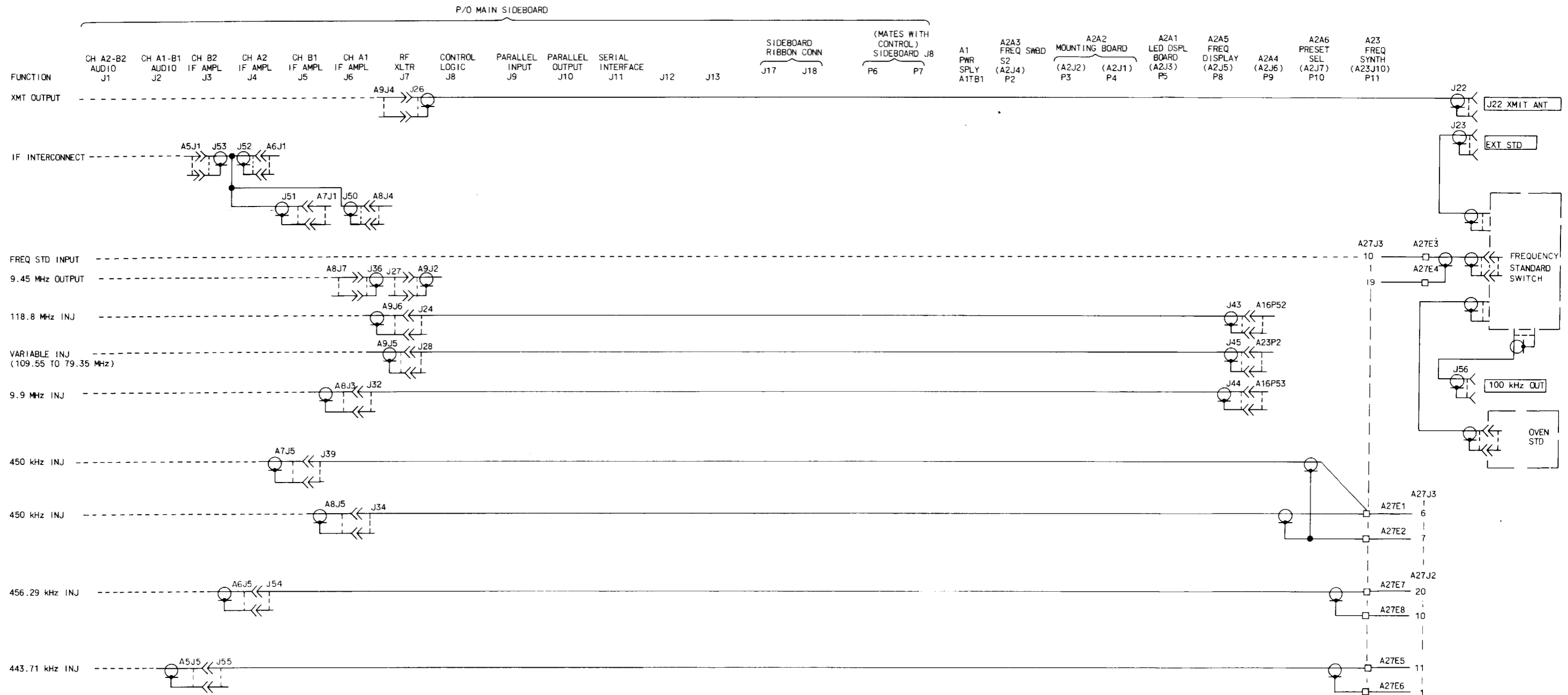

634-6820  
TPA-2511-014

Chassis, Main Sideboard and Ribbon Cabling.  
Schematic Diagram  
Figure 1 (Sheet 6)

**SCHEMATIC CHANGES**

REVISION IDENTIFICATION	DESCRIPTION OF REVISION AND REASON FOR CHANGE	SERVICE BULLETIN	EFFECTIVITY
	<p>(This page will contain schematic revision information.)</p>		

*Front Panel Assembly A2 (634-8199-XXX), Schematic Diagram  
Figure 2 (Sheet A)*

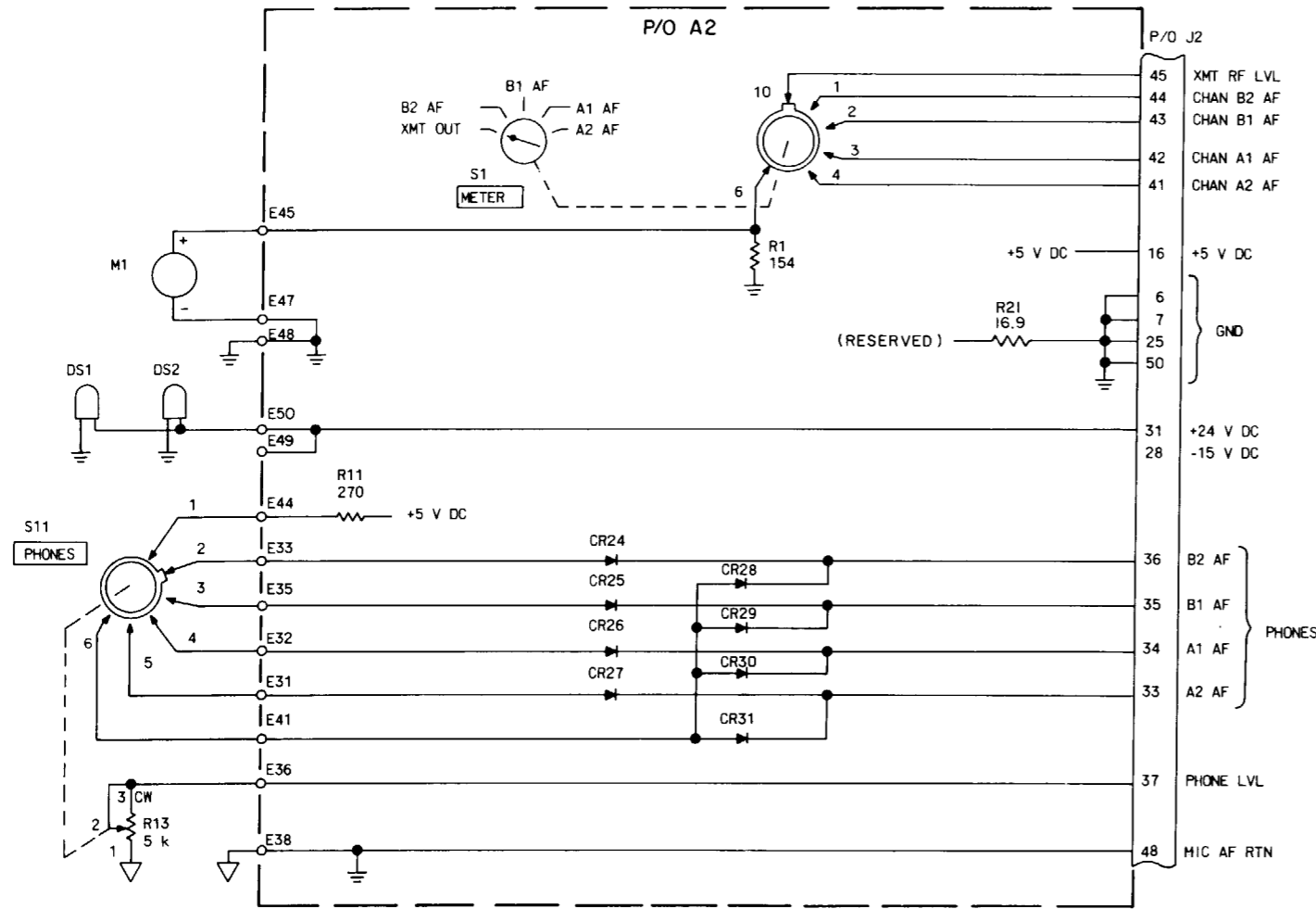

- NOTES:
1. UNLESS OTHERWISE SPECIFIED; RESISTANCE VALUES ARE IN OHMS, CAPACITANCE VALUES ARE IN MICROFARADS AND DIODES ARE TYPE 1N4454.
  2. PARTIAL REFERENCE DESIGNATIONS ARE SHOWN; FOR COMPLETE DESIGNATION, PREFIX WITH UNIT AND/OR ASSEMBLY DESIGNATION.

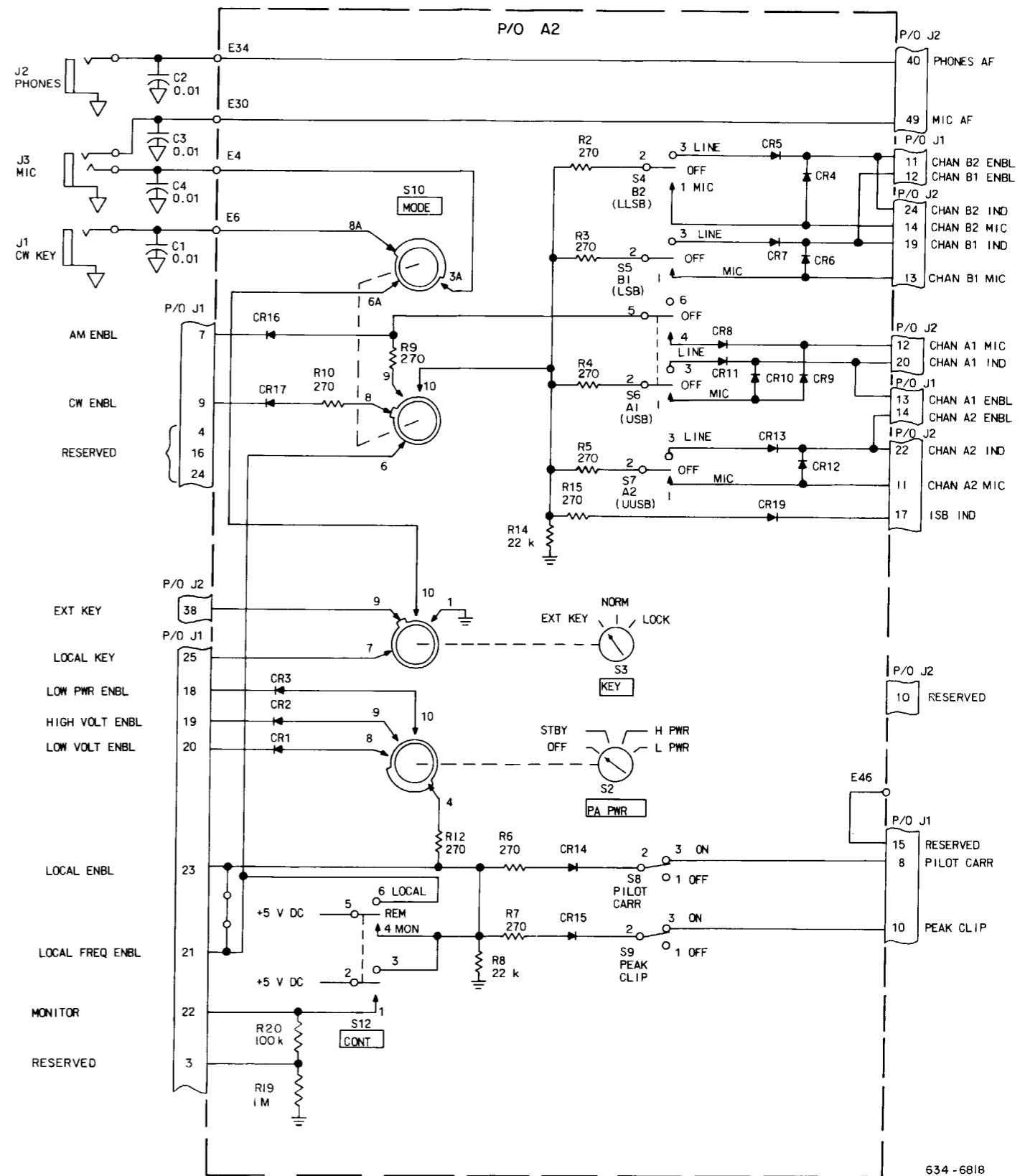

Front Panel Assembly A2 (634-8199-XXX),  
Schematic Diagram  
Figure 2 (Sheet 1 of 5)

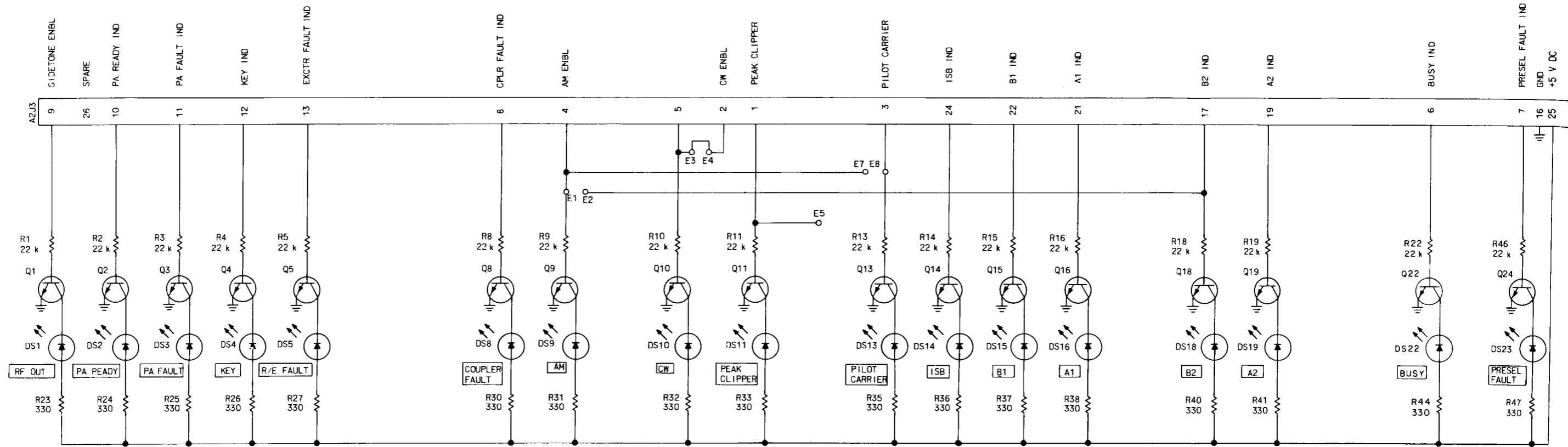

- NOTES:
1. UNLESS OTHERWISE SPECIFIED; RESISTANCE VALUES ARE IN OHMS.
  2. Q1-Q24 ARE TYPE 2N2222A. DS3, DS5, DS8 AND DS23 ARE TYPE HP5082-4684 (RED) LED. ALL OTHER DS'S ARE TYPE HP5082-4584 (YELLOW) LED.
  3. PARTIAL REFERENCE DESIGNATIONS ARE SHOWN; FOR COMPLETE DESIGNATION PREFIX WITH UNIT AND/OR ASSEMBLY DESIGNATION.
  4. TYPE DESIGNATIONS SHOWN MAY BE GENERIC IN FORM AND ARE FOR REFERENCE ONLY. SEE APPLICABLE PARTS LIST FOR REPLACEMENT PARTS.
  5. DS22 (BUSY) FUNCTIONAL ON HF-8093 ONLY.

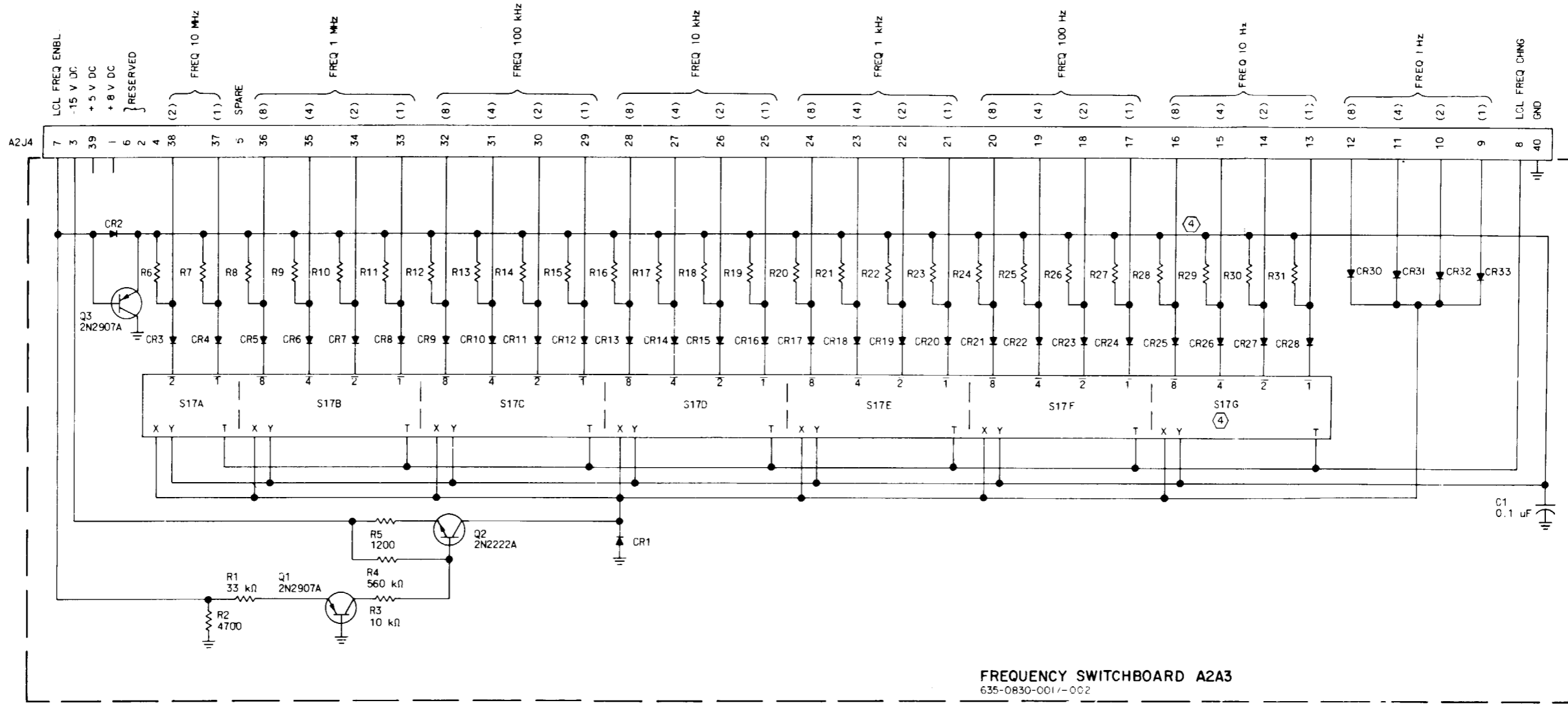

- NOTES:
- ① ALL DIODES ARE TYPE 1N4454
  - ② UNLESS OTHERWISE SPECIFIED, RESISTANCE VALUES ARE IN OHMS. R6-R35 ARE 33kΩ.
  - ③ PARTIAL REFERENCE DESIGNATIONS ARE SHOWN; FOR COMPLETE DESIGNATION, PREFIX WITH UNIT AND/OR ASSEMBLY DESIGNATION.
  - ④ S17G, R28, R29, R30, R31, USED ONLY ON 635-0830-002. WHEN S17G NOT USED, CR25, CR26, CR27, AND CR28 CATHODES CONNECTED TO S17F-X.

CIRCUITS USED PER FREQUENCY DISPLAY

CIRCUIT	637-1781-( )									
	-001	-002	-003	-004	-005	-006	-007	-008	-009	-010
U1			X	X	X			X	X	X
U2			X	X	X			X	X	X
U3			X	X	X			X	X	X
U4			X	X	X			X	X	X
U5			X	X	X			X	X	X
U6	X	X	X	X	X	X	X	X	X	X
U7	X	X	X	X	X	X	X	X	X	X
U8	X	X	X	X	X	X	X	X	X	X
U9	X	X	X	X	X	X	X	X	X	X
U10	X	X	X	X	X	X	X	X	X	X
U11	X	X	X	X	X	X	X	X	X	X
U12	X	X	X	X	X	X	X	X	X	X
U13		X	X	X	X			X	X	X
U14		X	X	X	X			X	X	X
U15			X	X				X	X	X
U16			X	X				X	X	X
U17			X	X				X	X	X
U18			X	X				X	X	X
U19			X	X				X	X	X
U20	X	X	X	X	X	X	X	X	X	X
U21	X	X	X	X	X	X	X	X	X	X
U22	X	X	X	X	X	X	X	X	X	X
U23	X	X	X	X	X	X	X	X	X	X
U24	X	X	X	X	X	X	X	X	X	X
U25	X	X	X	X	X	X	X	X	X	X
U26		X	X	X				X	X	X
U27			X	X				X	X	X

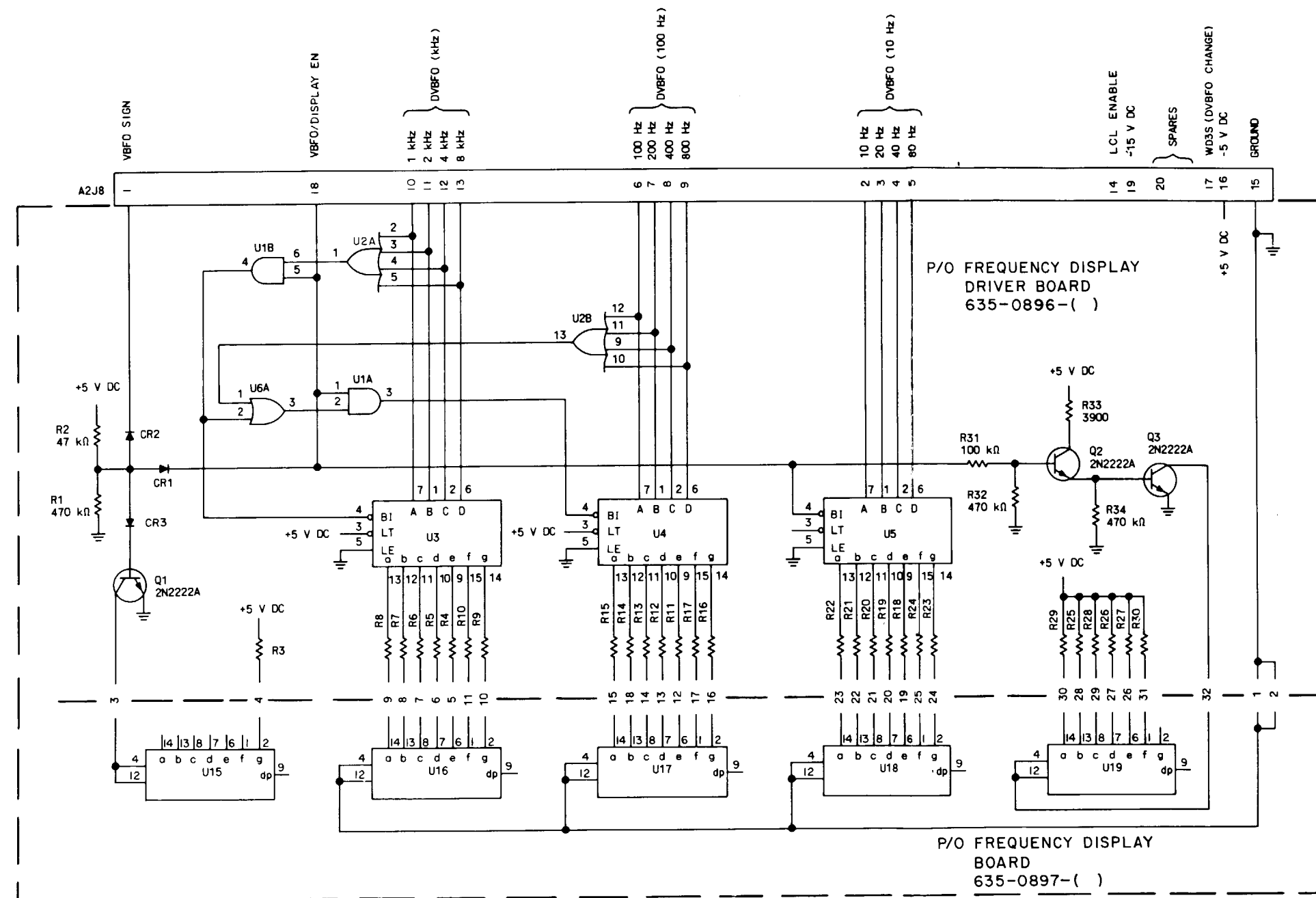

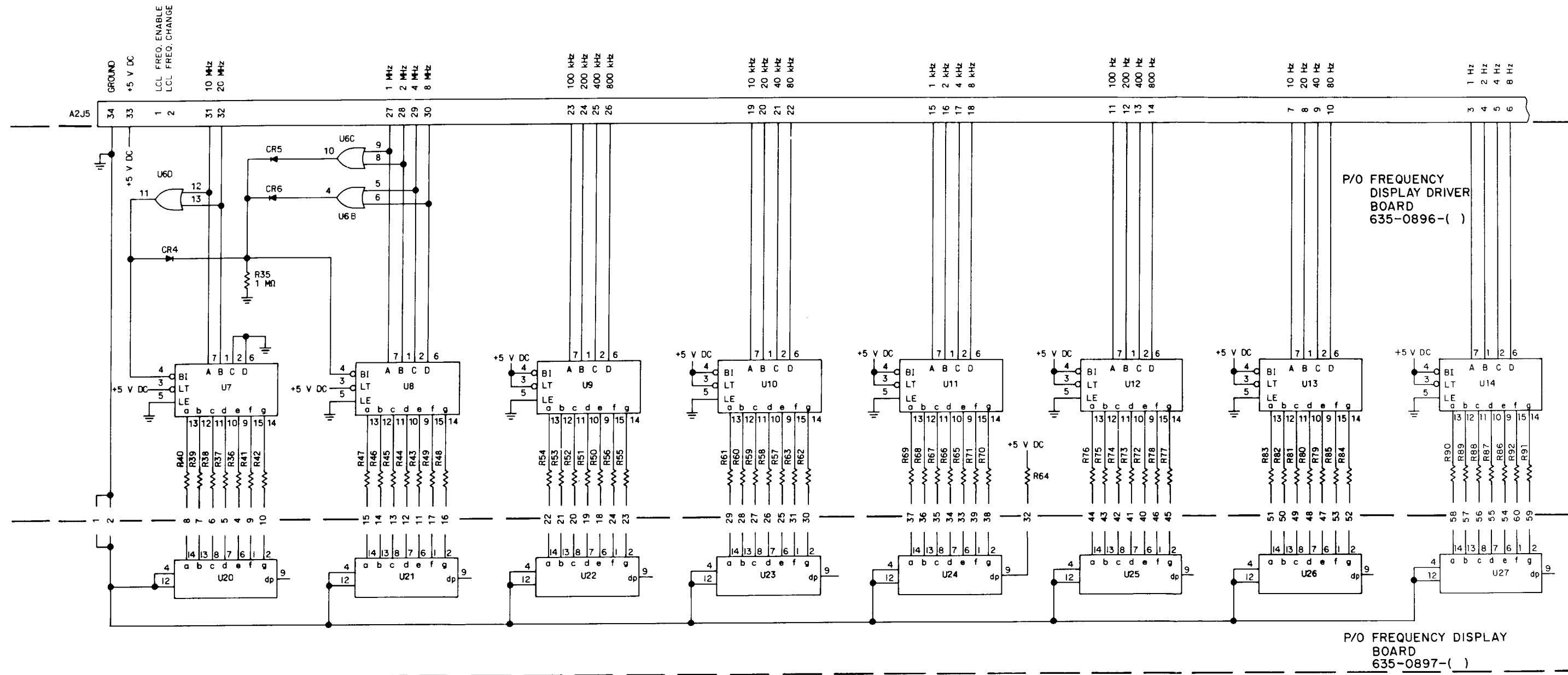

NOTES:

- ① RESISTORS R3 THRU R30 AND R36 THRU R92 ARE 180 OHM.
- ② DIODES ARE TYPE 1N4454.

③ POWER AND GROUND CONNECTIONS

U NO.	TYPE	POWER (V DC)	
		+5	GND
U1	MC14081BCP	14	7
U2	MC14072BCP	14	7
U3, U4, U5, AND U7 THRU U14	MC14511BCP	16	8
U6	MC14071BCP	14	7
U15 THRU U27	MAN3640A		



**SCHEMATIC CHANGES**

REVISION IDENTIFICATION	DESCRIPTION OF REVISION AND REASON FOR CHANGE	SERVICE BULLETIN	EFFECTIVITY
	<p>(This page will contain schematic revision information.)</p>		

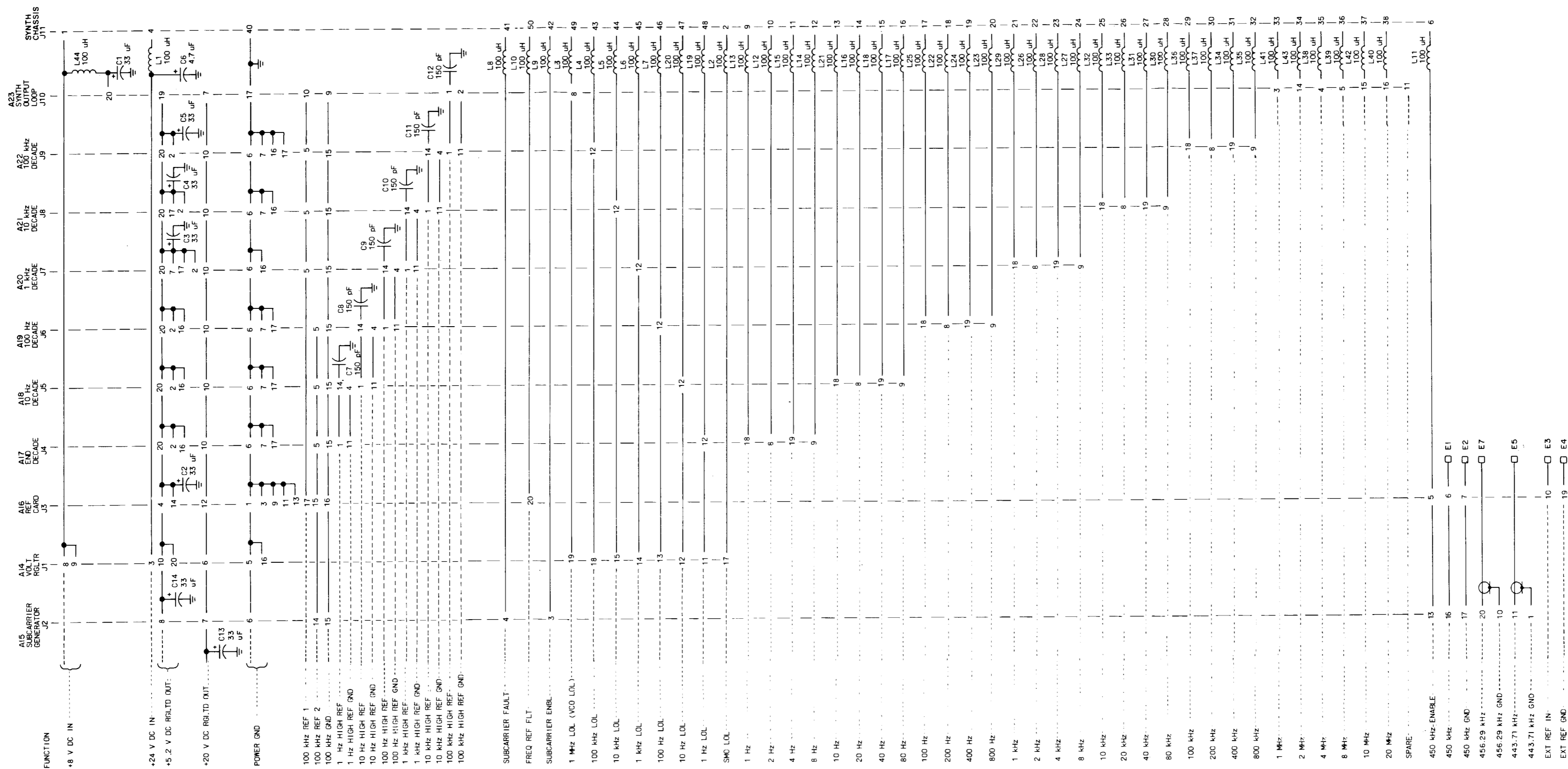

Synthesizer Chassis A27 (634-8201-001)  
Figure 3



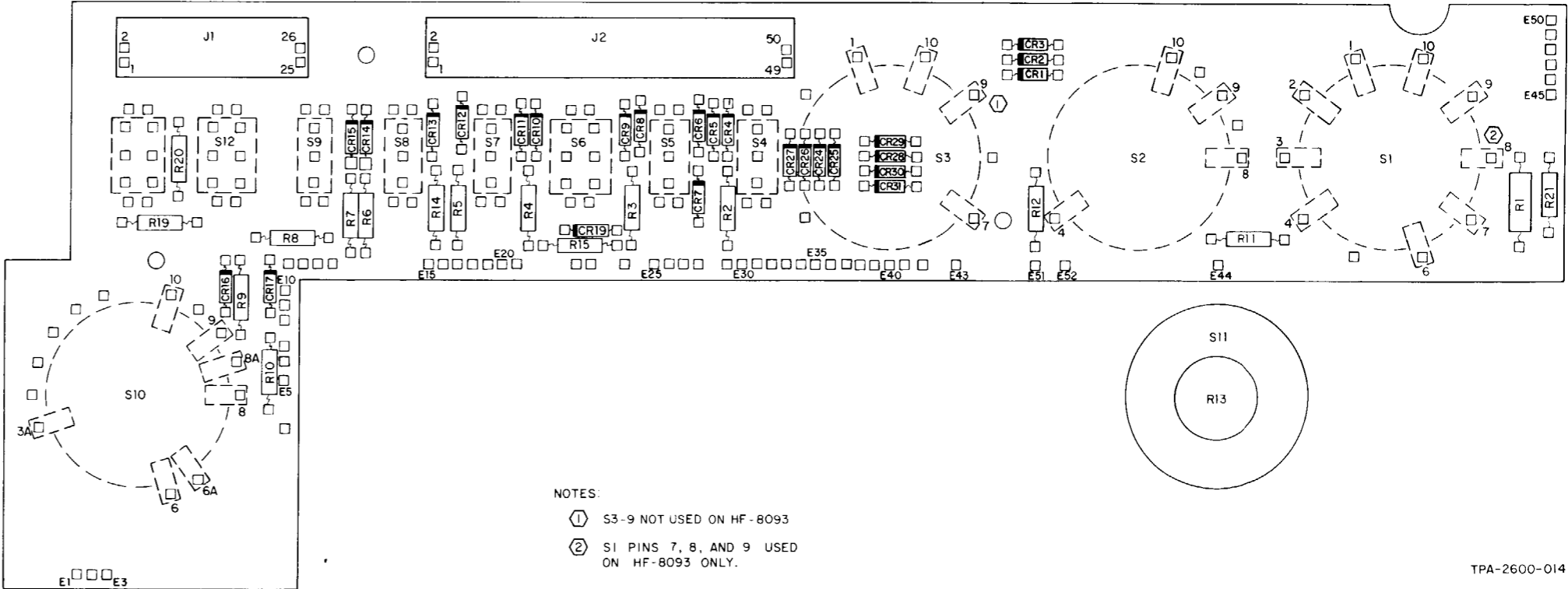

TPA-2600-014

Switch Mounting Board A2A2, Layout and Pin Numbering  
Figure 5

CONTROL / STATUS BIT				CONTROL / STATUS BIT				CONTROL / STATUS BIT				CONTROL / STATUS BIT																						
WORD FORMAT				EXCITER, AND EXCITER CONTROL				RECEIVER, AND RECEIVER CONTROL				WORD FORMAT				EXCITER, AND EXCITER CONTROL				RECEIVER, AND RECEIVER CONTROL														
WORD NO.	CHARACTER NO.	BIT NO.	BIT WT.	PARALLEL OUTPUT PIN NO.	PARALLEL INPUT PIN NO.	FUNCTION	PARALLEL OUTPUT PIN NO.	PARALLEL INPUT PIN NO.	FUNCTION	WORD NO.	CHARACTER NO.	BIT NO.	BIT WT.	PARALLEL OUTPUT PIN NO.	PARALLEL INPUT PIN NO.	FUNCTION	PARALLEL OUTPUT PIN NO.	PARALLEL INPUT PIN NO.	FUNCTION	WORD NO.	CHARACTER NO.	BIT NO.	BIT WT.	PARALLEL OUTPUT PIN NO.	PARALLEL INPUT PIN NO.	FUNCTION	PARALLEL OUTPUT PIN NO.	PARALLEL INPUT PIN NO.	FUNCTION					
1	2	8		1	6	8			NOT USED							NOT USED			NOT USED							NOT USED			NOT USED			NOT USED		
1	2	7		1	6	4			NOT USED							NOT USED			NOT USED							NOT USED			NOT USED			NOT USED		
1	2	6		1	6	2	129	129	FREQ 10 MHz (2)	129	129	FREQ 10 MHz (2)	3	2	8	3	6	8			NOT USED							NOT USED			NOT USED			NOT USED
1	2	5		1	6	1	64	64	FREQ 10 MHz (1)	64	64	FREQ 10 MHz (1)	3	2	7	3	6	4	107	107	NOT USED					107	107	NOT USED			NOT USED			NOT USED
1	2	4		1	7	8	128	128	FREQ 1 MHz (8)	128	128	FREQ 1 MHz (8)	3	2	6	3	6	2	48	48	NOT USED					48	48	NOT USED			NOT USED			NOT USED
1	2	3		1	7	4	63	63	FREQ 1 MHz (4)	63	63	FREQ 1 MHz (4)	3	2	5	3	6	1	113	113	VBFO SIGN					113	113	VBFO SIGN			VBFO SIGN			VBFO SIGN
1	2	2		1	7	2	127	127	FREQ 1 MHz (2)	127	127	FREQ 1 MHz (2)	3	2	4	3	7	8	47	47	NOT USED					47	47	NOT USED			NOT USED			NOT USED
1	2	1		1	7	1	62	62	FREQ 1 MHz (1)	62	62	FREQ 1 MHz (1)	3	2	3	3	7	4	112	112	NOT USED					112	112	NOT USED			NOT USED			NOT USED
1	3	8		1	8	8	126	126	FREQ 100 kHz (8)	126	126	FREQ 100 kHz (8)	3	3	8	3	8	8			NOT USED							NOT USED			NOT USED			NOT USED
1	3	7		1	8	4	61	61	FREQ 100 kHz (4)	61	61	FREQ 100 kHz (4)	3	3	7	3	8	4			NOT USED							NOT USED			NOT USED			NOT USED
1	3	6		1	8	2	125	125	FREQ 100 kHz (2)	125	125	FREQ 100 kHz (2)	3	3	6	3	8	2			NOT USED							NOT USED			NOT USED			NOT USED
1	3	5		1	8	1	60	60	FREQ 100 kHz (1)	60	60	FREQ 100 kHz (1)	3	3	5	3	8	1			NOT USED							NOT USED			NOT USED			NOT USED
1	3	4		1	9	8	124	124	FREQ 10 kHz (8)	124	124	FREQ 10 kHz (8)	124	124	FREQ 10 kHz (8)	3	3	4	3	9	8			NOT USED							NOT USED			NOT USED
1	3	3		1	9	4	59	59	FREQ 10 kHz (4)	59	59	FREQ 10 kHz (4)	124	124	FREQ 10 kHz (4)	3	3	3	3	9	4			NOT USED							NOT USED			NOT USED
1	3	2		1	9	2	123	123	FREQ 10 kHz (2)	123	123	FREQ 10 kHz (2)	59	59	FREQ 10 kHz (2)	3	3	2	3	9	2			NOT USED							NOT USED			NOT USED
1	3	1		1	9	1	58	58	FREQ 10 kHz (1)	58	58	FREQ 10 kHz (1)	123	123	FREQ 10 kHz (1)	3	3	1	3	9	1			NOT USED							NOT USED			NOT USED
1	4	8		1	10	8	122	122	FREQ 1 kHz (8)	122	122	FREQ 1 kHz (8)	122	122	FREQ 1 kHz (8)	3	4	8	3	10	8	7	7	NOT USED					7	7	NOT USED			NOT USED
1	4	7		1	10	4	57	57	FREQ 1 kHz (4)	57	57	FREQ 1 kHz (4)	57	57	FREQ 1 kHz (4)	3	4	7	3	10	4	8	8	NOT USED					8	8	NOT USED			NOT USED
1	4	6		1	10	2	121	121	FREQ 1 kHz (2)	121	121	FREQ 1 kHz (2)	121	121	FREQ 1 kHz (2)	3	4	6	3	10	2			NOT USED							NOT USED			NOT USED
1	4	5		1	10	1	56	56	FREQ 1 kHz (1)	56	56	FREQ 1 kHz (1)	56	56	FREQ 1 kHz (1)	3	4	5	3	10	1			NOT USED							NOT USED			NOT USED
1	4	4		1	11	8	120	120	FREQ 100 Hz (8)	120	120	FREQ 100 Hz (8)	120	120	FREQ 100 Hz (8)	3	4	4	3	11	8			NOT USED							NOT USED			NOT USED
1	4	3		1	11	4	55	55	FREQ 100 Hz (4)	55	55	FREQ 100 Hz (4)	55	55	FREQ 100 Hz (4)	3	4	3	3	11	4			NOT USED							NOT USED			NOT USED
1	4	2		1	11	2	119	119	FREQ 100 Hz (2)	119	119	FREQ 100 Hz (2)	119	119	FREQ 100 Hz (2)	3	4	2	3	11	2			NOT USED							NOT USED			NOT USED
1	4	1		1	11	1	54	54	FREQ 100 Hz (1)	54	54	FREQ 100 Hz (1)	54	54	FREQ 100 Hz (1)	3	4	1	3	11	1			NOT USED							NOT USED			NOT USED
1	5	8		1	12	8	118	118	FREQ 10 Hz (8)	118	118	FREQ 10 Hz (8)	118	118	FREQ 10 Hz (8)	3	5	8	3	12	8			NOT USED							NOT USED			NOT USED
1	5	7		1	12	4	53	53	FREQ 10 Hz (4)	53	53	FREQ 10 Hz (4)	53	53	FREQ 10 Hz (4)	3	5	7	3	12	4			NOT USED							NOT USED			NOT USED
1	5	6		1	12	2	117	117	FREQ 10 Hz (2)	117	117	FREQ 10 Hz (2)	117	117	FREQ 10 Hz (2)	3	5	6	3	12	2			NOT USED							NOT USED			NOT USED
1	5	5		1	12	1	52	52	FREQ 10 Hz (1)	52	52	FREQ 10 Hz (1)	52	52	FREQ 10 Hz (1)	3	5	5	3	12	1			NOT USED							NOT USED			NOT USED
1	5	4		1	13	8	116	116	FREQ 1 Hz (8)	116	116	FREQ 1 Hz (8)	116	116	FREQ 1 Hz (8)	3	5	4	3	13	8			NOT USED							NOT USED			NOT USED
1	5	3		1	13	4	51	51	FREQ 1 Hz (4)	51	51	FREQ 1 Hz (4)	51	51	FREQ 1 Hz (4)	3	5	3	3	13	4			NOT USED							NOT USED			NOT USED
1	5	2		1	13	2	115	115	FREQ 1 Hz (2)	115	115	FREQ 1 Hz (2)	115	115	FREQ 1 Hz (2)	3	5	2	3	13	2			NOT USED							NOT USED			NOT USED
1	5	1		1	13	1	50	50	FREQ 1 Hz (1)	50	50	FREQ 1 Hz (1)	50	50	FREQ 1 Hz (1)	3	5	1	3	13	1			NOT USED							NOT USED			NOT USED
2	2	8		2	6	8			NOT USED			NOT USED									NOT USED							NOT USED			NOT USED			
2	2	7		2	6	4			NOT USED			NOT USED									NOT USED							NOT USED			NOT USED			
2	2	6		2	6	2	76	76	NOT USED	76	76	NOT USED	76	76	NOT USED	4	2	8	4	6	8	(12)	13	NOT USED					(12)	13	NOT USED			NOT USED
2	2	5		2	6	1	11	11	NOT USED	11	11	NOT USED	11	11	NOT USED	4	2	6	4	6	2	92	(68)	EXCTR FLT					92	(68)	EXCTR FLT			RCVR FLT
2	2	4		2	7	8	10	10	NOT USED	10	10	NOT USED	10	10	NOT USED	4	2	5	4	6	1	68	68	REMOTE KEY (MON)					68	68	REMOTE KEY (MON)			RF OVLD FLT
2	2	3		2	7	4	75	75	NOT USED	75	75	NOT USED	75	75	NOT USED	4	2	4	4	7	8	88	88	B2 AF MON					88	88	B2 AF MON			B2 AF MON
2	2	2		2	7	2	10	10	NOT USED	10	10	NOT USED	10	10	NOT USED	4	2	3	4	7	4	23	23	B1 AF MON					23	23	B1 AF MON			B1 AF MON
2	2	1		2	7	1	22	22	NOT USED	22	22	NOT USED	22	22	NOT USED	4	2	2	4	7	2	22	22	A1 AF MON					22	22	A1 AF MON			A1 AF MON
2	3	8		2	8	8	3	12	NOT USED	3	12	FL7 (E) ENBL	3	12	FL7 (E) ENBL	4	3	8	4	8	8	24	24	A2 AF MON					24	24	A2 AF MON			A2 AF MON
2	3	7		2	8	4	41	41	NOT USED	41	41	FL6 (D) ENBL	41	41	FL6 (D) ENBL	4	3	7	4	8	4	(2)	2	NOT USED					(2)	2	NOT USED			NOT USED
2	3	6		2	8	2	106	106	NOT USED	106	106	FL5 (C) ENBL	106	106	FL5 (C) ENBL	4	3	6	4	8	2	(40)	40	10 Hz LOCK IND					(40)	40	10 Hz LOCK IND			10 Hz LOCK IND
2	3	5		2	8	1	37	37	NOT USED	37	37	FL4 (B) ENBL	37	37	FL4 (B) ENBL	4	3	5	4	8	1	105	105	100 Hz LOCK IND					105	105	100 Hz LOCK IND			100 Hz LOCK IND
2	3	4		2	9	8	84	84	NOT USED	84	84	B2 AGC (2)	84	84	B2 AGC (2)	4	3	4	4	8	1	36	36	1 kHz LOCK IND					36	36	1 kHz LOCK IND			1 kHz LOCK IND
2	3	3		2	9	4	85	85	NOT USED	85	85	B2 AGC (1)	85	85	B2 AGC (1)	4	3	3	4	8	1	83	83	10 kHz LOCK IND					83	83	10 kHz LOCK IND			10 kHz LOCK IND
2	3	2		2	9	2	19	19	NOT USED	19	19	A2 AGC (2)	19	19	A2 AGC (2)	4	3	2	4	8	2	39	39	100 kHz LOCK IND					39	39	100 kHz LOCK IND			100 kHz LOCK IND
2	3	1		2	9	1	20	20	NOT USED	20	20	A2 AGC (1)	20	20	A2 AGC (1)	4	3	1	4	8	1	101	101	SYNTH OUT LOCK IND					101	101	SYNTH OUT LOCK IND			SYNTH OUT LOCK IND
2	4	8		2	10	8	100	100	NOT USED	100	100	FL3 (A) ENBL	100	100	FL3 (A) ENBL	4	4	8	4	10	8	18	18	FREQ REF FLT					18	18	FREQ REF FLT			FREQ REF FLT
2	4	7		2	10	4	99	99	NOT USED	99	99	FL1 (16 kHz) ENBL	99	99	FL1 (16 kHz) ENBL	4	4	7	4	10	4	(69)	69	NOT USED					(69)	69	NOT USED			NOT USED
2	4	6		2	10	2	35	35	NOT USED	35	35	VBFO ENBL	35	35	VBFO ENBL	4	4	6	4	10	2	(77)	4	SUBCARRIER LOCK										