



**Rockwell
International**

Collins instruction book

**HF-8040()
Antenna Coupler**

This instruction book includes:

<i>Description</i>	523-0767459
<i>HF-8040M Supplement</i>	523-0771398
<i>Installation</i>	523-0767460
<i>Operation</i>	523-0767461
<i>Theory</i>	523-0767462
<i>Maintenance</i>	523-0767463
<i>Parts List</i>	523-0767464
<i>Diagrams</i>	523-0767465
<i>Control Module</i>	523-0771620
<i>Coil Module</i>	523-0767698
<i>Capacitor Module</i>	523-0767699
<i>Discriminator Module</i>	523-0767700

**Collins Telecommunications
Products Division
Defense Electronics Operations
Rockwell International
Cedar Rapids, Iowa 52498**

670-3022

3.0 REQUIREMENTS

3.1 ITEM DEFINITION

THE HF-8040 ANTENNA COUPLER IS DESIGNED SPECIFICALLY TO AUTOMATICALLY MATCH A VARIETY OF GROUND STATION ANTENNAS TO THE 50 OHM COAXIAL OUTPUT OF THE HF-8023 POWER AMPLIFIER IN THE 1.6 MHZ TO 30 MHZ FREQUENCY RANGE.

3.2 CHARACTERISTICS

3.2.1 PERFORMANCE

3.2.1.1 TYPE OF SERVICE

CONTINUOUS, AUTOMATIC, REMOTE CONTROLLED.

3.2.1.2 INPUT POWER

105/210, 115/230, 122/244 \pm 10% VAC, 50/60 HZ, SINGLE PHASE, 200 V.A. MAXIMUM.

3.2.1.3 FREQUENCY RANGE (REFER TO 3.2.1.7)

1.6 TO 30 MHZ, SEE 3.2.1.7 FOR ANTENNA RESTRICTIONS.

3.2.1.4 RF TUNE POWER

100 TO 200 WATTS WHEN MEASURED INTO 50 OHMS.

3.2.1.5 RF POWER INPUT (MAXIMUM)

1000 WATTS AVERAGE
1260 WATTS P.E.P.

3.2.1.6 RF DUTY CYCLE

CONTINUOUS

ROCKWELL INTERNATIONAL CORPORATION
COLLINS GROUPS

DALLAS, TEX 75207 NEWPORT BEACH, CALIF 92663 CEDAR RAPIDS, IA 52409

PREP	G. SNIDER	SIZE	FSCM	DWG NO.	REV
		A	13499	670-3022	LTR
CHK	J MORGAN	SCALE	NONE	SHEET	3

3.2.1.7 ANTENNA IMPEDANCE

THE HF-8040 ANTENNA COUPLER WILL TUNE TYPICAL ANTENNAS AS LISTED BELOW. MANY ANTENNAS WHICH ARE WITHIN THE RANGE OF THE TUNING ELEMENTS HAVE NOT BEEN LISTED. FOR EACH UNSPECIFIED ANTENNA, A DETAILED COMPUTER ANALYSIS MUST BE PERFORMED.

<u>ANTENNA</u>	<u>FREQ. RANGE</u>
*35 FT. (10.7M) WHIP OR LONGER	1.6 MHZ - 30 MHZ
*OPEN LONGWIRE (45 FT., 13.7M)	1.6 MHZ - 30 MHZ
VSWR 4:1	1.6 MHZ - 30 MHZ

*SHORTER WHIPS AND WIRES MAY BE USED. LIMITED LOW FREQUENCY SELECTION IS NECESSARY DUE TO EXTREMELY HIGH ANTENNA VOLTAGE. NO DAMAGE TO THE COUPLER WILL RESULT BECAUSE OF INTERNAL VOLTAGE FAULT PROTECTION.

3.2.1.8 INPUT IMPEDANCE (TUNED)

50 OHMS 1.3:1 VSWR MAXIMUM, 1.1:1 TYPICAL.

3.2.1.9 TUNE TIME

3 SECONDS TYPICAL, 7 SECONDS MAXIMUM.

3.2.1.10 WARM-UP TIME

NONE

3.2.2 PHYSICAL CHARACTERISTICS

3.2.2.1 SIZE

WIDE: 22.5 IN. (57.15CM) MAX. HIGH: 15.0 IN. (38.10 CM) MAX.
LONG: 41 IN. (104.15 CM)

3.2.2.2 WEIGHT

90 POUNDS MAX.

ROCKWELL INTERNATIONAL CORPORATION
COLLINS GROUPS

DALLAS, TEX 75207 NEWPORT BEACH, CALIF 92663 CEDAR RAPIDS, IA 52409

PREP G. SNIDER	SIZE A	FSCM 13499	DWG NO. 670-3022	REV LTR —
CHK J MORGAN	SCALE NONE		SHEET 4	

5
DWG NO. 670-3022

3.2.2.3 INTERFACE

THE HF-8040 IS COMPLETELY COMPATIBLE WITH THE 1000 WATT HF-80 COMMUNICATION SYSTEMS.

3.2.2.3.1 LOGIC LEVEL DEFINITION

INPUT LINES SHALL BE A 4000 SERIES CMOS GATE WITH A PULL-UP RESISTOR TO V_{DD}

(V_{DD} = 12 VDC 9 VDC MIN., 28 VDC MAX.)

OUTPUT LINES SHALL BE OPEN COLLECTOR TRANSISTORS. THE OUTPUT LINES SHALL BE CAPABLE OF SINKING 10 MA MAXIMUM EXCEPT KEYLINE WHICH WILL BE CAPABLE OF SINKING 50 MA MAXIMUM.

LOGIC VOLTAGE LEVELS ARE DEFINED AS:

LOGIC 0 0 - 2.5 VOLTS
LOGIC 1 9 - 28 VOLTS (OR OPEN)

**ROCKWELL INTERNATIONAL CORPORATION
COLLINS GROUPS**

DALLAS, TEX 75207 WPORT BEACH, CALIF 92063 CEDAR RAPIDS, IA 52498

PREP	G. SNIDER	SIZE	FSCM	DWG NO.	REV
		A	13499	670-3022	LTR —
CHK	J MORGAN	SCALE	NONE	SHEET	5

6
DWG NO. 670-3022

3.2.2.3.2 INTERCONNECT DEFINITION

<u>CONNECTOR</u>	<u>DEFINITION</u>	<u>FUNCTION</u>
P1-b P1-c	INPUT AC INPUT AC	THE COUPLER REQUIRES 230 VAC 50/60 HZ 200 VA MAX. SINGLE PHASE POWER. INTERNAL STRAPPING OPTION REQUIRED FOR OPTIONAL VOLTAGE OPERATION.
P1-E	KEYLINE	THE COUPLER REQUIRES A LOGIC 0 ON THIS LINE TO BEGIN A TUNE CYCLE. ONCE A TUNE CYCLE HAS STARTED THE COUPLER WILL LATCH THE KEYLINE AT A LOGIC 0 UNTIL THE COUPLER TUNES OR REACHES A FAULT CONDITION.
P1-J	TUNE START	THE COUPLER REQUIRES A LOGIC 0 PULSE (50 MS TO 200 MS) ON THIS LINE EACH TIME THE TRANSMIT FREQUENCY IS CHANGED. AFTER A TUNE START PULSE THE COUPLER WILL DISABLE THE KEY INTERLOCK AND AUTOMATICALLY POSITION THE RFTUNING ELEMENTS IN THE HOME POSITION.
P1-A	FAULT	THE COUPLER WILL TRANSMIT A LOGIC ONE ON THIS LINE ANY TIME THE COUPLER REQUIRES LONGER THAN 5 SECONDS TO TUNE OR EXCESSIVE VOLTAGE APPEARS AT THE TERMINAL.
P1-C	KEY INTERLOCK	THE COUPLER SENDS A LOGIC 0 ON THIS LINE WHEN IT IS READY TO ACCEPT RF POWER FROM THE POWER AMPLIFIER. THIS LINE IS NORMALLY AT A LOGIC 1 AND WILL BE LATCHED AT A LOGIC 1 WHEN THE COUPLER IS IN THE FAULT MODE. THE LINE WILL BE AT A LOGIC 0 APPROXIMATELY 100 MS AFTER THE KEYLINE IS AT A LOGIC 0 TO ALLOW FOR THE OPERATION OF THE RECEIVE/TRANSMIT RELAYS.
P1-H	RESERVED	NOT REQUIRED FOR COUPLER OPERATION.

ROCKWELL INTERNATIONAL CORPORATION
COLLINS GROUPS
DALLAS, TEX 75207 MI YPORT BEACH, CALIF 92083 CEDAR RAPIDS, IA 52498

PREP G. SNIDER	SIZE A	FSCM 13499	DWG NO. 670-3022	REV LTR —
CHK J MORGAN	SCALE NONE		SHEET 6	

DWG NO. 670-3022

3.2.2.3.2 INTERCONNECT DEFINITION (CONTINUED)

<u>CONNECTOR</u>	<u>DEFINITION</u>	<u>FUNCTION</u>
P1-G	TUNE POWER	THE COUPLER SENDS A LOGIC 0 ON THIS LINE WHEN IT IS NOT IN A TUNED CONDITION. RF POWER TRANSMITTED TO THE COUPLER WHILE THIS LINE IS LOW MUST BE FROM 100 WATTS TO 200 WATTS AND ALSO MUST BE A CW SIGNAL.
P1-T	GROUND (DC)	COMMON DC GROUND.
P1-M	RECEIVE	THE COUPLER REQUIRES A LOGIC 0 ON THE LINE TO DISABLE THE RECEIVE TRANSMIT RELAYS. WHEN A LOGIC 0 APPEARS ON THIS LINE THE RF ELEMENTS REMAIN IN THE TRANSMIT MODE TO ALLOW FOR RECEIVING THROUGH A TUNED RF NETWORK.
P1-W	SHIELD	SHIELDED GROUND FOR CONTROL CABLE.
P1-m	GROUND (DC)	COMMON DC GROUND.
P-1d	LOW POWER	IN THE EVENT AMBIENT CONDITIONS CAUSE THE COUPLER TO REACH EXCESSIVE INTERNAL TEMPERATURES A LOGIC 0 WILL BE SENT ON THIS LINE. THIS LOGIC 0 MUST CAUSE THE POWER AMPLIFIER TO REDUCE THE RF OUTPUT POWER APPROXIMATELY 500 WATTS.

3.2.2.3.3 GROUNDING

THE HF-8040 ANTENNA COUPLER REQUIRES A GROUND STRAP FOR PROPER OPERATION. THE STRAP MUST BE 1" WIDE FOR EACH 1 FOOT OF LENGTH REQUIRED TO REACH THE ANTENNA RADIAL SYSTEM. GROUNDING CAN ALSO BE ACCOMPLISHED BY MOUNTING THE UNIT ON A METAL SURFACE AND MAKING ELECTRICAL CONTACT TO THE TOP SURFACE OF THE MOUNTING FEET. THE GROUND CONNECTION MUST BE INSPECTED AND CLEANED IF EVIDENCE OF CORROSION IS PRESENT.

3.2.2.3.4 SAFETY CAUTION

RF VOLTAGE HIGH RF VOLTAGE APPEARS AT THE ANTENNA INSULATOR AND ANTENNA BASE. VOLTAGES AS HIGH AS 15,000 VOLTS CAN CAUSE SEVERE BURNING ON CONTACT OR NEAR CONTACT.

**ROCKWELL INTERNATIONAL CORPORATION
COLLINS GROUPS**

DALLAS, TEX. 75207 NEWPORT BEACH, CALIF. 92663 CEDAR RAPIDS, IA 52406

PREP G. SNIDER	SIZE	FSCM	DWG NO.	REV
	A	13499	670-3022	LTR —
CHK J MORGAN	SCALE	NONE	SHEET	7

3.2.2.3.5 PROTECTIVE FEATURES

THE FOLLOWING PROTECTIVE CIRCUITS ARE PROVIDED:

1. TUNE FAILURE - DETECTS FAILURE TO COMPLETE A TUNE IN APPROXIMATELY 7 SECONDS.
2. HIGH VOLTAGE - DETECTS AN RF VOLTAGE CONDITION WHICH MAY DAMAGE THE COUPLER.

3.2.2.3.6 PERFORMANCE MONITORS

1. FAULT - MONITOR WHICH PROVIDES INFORMATION THAT A TUNE FAILURE OR HIGH VOLTAGE CONDITION HAS OCCURRED.
2. RETUNE - CONSTANT SURVEILLANCE OF VSWR. WHEN HIGH VSWR IS DETECTED SERVOS ARE ENERGIZED FOR 0.5 SECOND.

3.2.3 RELIABILITY

3.2.3.1 GENERAL

A RELIABILITY PROGRAM, APPROPRIATE FOR THE INTENDED END USAGE OF THE UNIT AND UTILIZING RECOGNIZED INDUSTRY-STANDARD TECHNIQUES, SHALL BE ESTABLISHED AND MAINTAINED TO ASSIST IN ACHIEVING CONFORMANCE WITH THE NUMERICAL RELIABILITY VALUE STATED HEREIN.

3.2.3.2 MEAN-TIME-BETWEEN-FAILURES

THE PREDICTED MEAN-TIME-BETWEEN-FAILURE (MTBF), CALCULATED USING MIL-HDBK-217C AS THE SOURCE FOR THE PART FAILURE RATE, SHALL BE 7430 HOURS.

3.2.3.3 LONGEVITY

THE UNIT SHALL BE DESIGNED FOR A MINIMUM LIFE EXPECTANCY, WITH REASONABLE REPAIR, OF 10 YEARS OR 50,000 HOURS OF OPERATION, WHICHEVER OCCURS FIRST.

3.2.4 MAINTAINABILITY

ROCKWELL INTERNATIONAL CORPORATION
COLLINS GROUPS

DALLAS, TEX 75207 NEWPORT BEACH, CALIF 92663 CEDAR RAPIDS, IA 52408

PREP G. SNIDER	SIZE A	FSCM 13499	DWG NO. 670-3022	REV LTR —
CHK J MORGAN	SCALE NONE		SHEET 8	

DWG NO. 670-3022 9

3.2.4.1 PACKAGING

ALL ELECTRICAL/ELECTRONIC CIRCUITS AND PARTS SHALL BE PACKAGED, TO THE MAXIMUM EXTENT POSSIBLE ON REPLACEABLE AND REPAIRABLE PLUG-IN MODULE, CIRCUIT BREAKERS, INDICATORS, SWITCHES AND OTHER ITEMS WHICH MAY LOGICALLY BE BOLTED AND SOLDERED, OR OTHERWISE MORE RIGIDLY ELECTRICALLY AND MECHANICALLY FASTENED TO A CHASSIS, SHALL NOT BE CONSIDERED MODULES. MODULE ARRANGEMENT SHALL BE SUCH THAT ACCESS TO ANY MODULE DOES NOT REQUIRE THE REMOVAL OF ADJACENT MODULES OR PARTS OTHER THAN ACCESS PANELS/COVERS. THE USE OF SPECIAL TOOL(S) FOR MODULE REMOVAL IS PROHIBITED.

3.2.4.1.1 TYPE OF CONSTRUCTION

THE HF-8040 ANTENNA COUPLER IS A WATERTIGHT UNIT CONSTRUCTED WITH A SEALED QUICK-RELEASE COVER. ALL PARTS EXCEPT CONNECTORS AND THE ANTENNA INSULATOR ARE LOCATED WITHIN THE COUPLER CASE.

3.2.4.1.2 TYPE OF MOUNTING

THE HF-8040 ANTENNA COUPLER IS HELD TO ITS MOUNTING SURFACE BY FOUR 1/4 INCH BOLTS. THE COUPLER MAY BE MOUNTED IN ANY POSITION EXCEPT TOP DOWN.

3.2.4.2 KEYING

CONNECTORS SHALL BE KEYED TO PREVENT THE INSERTION OF A CONNECTOR OR SUBASSEMBLY INTO AN IMPROPER LOCATION WITHIN OR ON A UNIT.

3.2.4.3 ACCESS PANELS

ACCESS PANELS/COVERS SHALL BE RETAINED BY QUICK-DISCONNECT FASTENERS UNLESS MORE RIGID FASTENING IS REQUIRED TO MAINTAIN MECHANICAL INTEGRITY OF THE UNIT.

3.2.4.4 ADJUSTMENTS

NO ADJUSTMENT AND/OR ALIGNMENT SHALL BE REQUIRED AT THE MAJOR EQUIPMENT/UNIT LEVEL WHEN IT IS REPLACED DURING A CORRECTIVE MAINTENANCE ACTION.

3.2.4.5 TEST POINTS

N/A

ROCKWELL INTERNATIONAL CORPORATION
COLLINS GROUPS
DALLAS, TEX 75207 NEWPORT BEACH, CALIF 92663 CEDAR RAPIDS, IA 52408

PREP G. SNIDER	SIZE A	FSCM 13499	DWG NO. 670-3022	REV LTR —
CHK J MORGAN	SCALE NONE		SHEET 9	

DWG NO. 670-3022

3.2.5 ENVIRONMENTAL CONDITIONS

3.2.5.1 AMBIENT TEMPERATURE RANGE

OPERATING -30°C TO +60°C
NON-OPERATING -65°C TO +70°C

3.2.5.2 AMBIENT HUMIDITY RANGE

0 TO 95% @ +40°C

3.2.5.3 ALTITUDE

0 TO 10,000 FT. ABOVE SEA LEVEL (0 TO 2540 M)

3.2.5.4 VIBRATION

PERFORMANCE:

0 TO 12.5 HZ 0.126" D.A. 1G MAX.
12.5 TO 25 HZ 0.032" D.A. 1G MAX.
25 TO 50 HZ 0.008" D.A. 1G MAX.

3.2.5.5 FUNGUS

THE EQUIPMENT SHALL NOT SUPPORT THE GROWTH OF FUNGUS.

3.2.5.6 WATER SEAL

THE COUPLER WILL REMAIN WATERTIGHT WITH PARTIAL SUBMERSION OF ANY PORTION OF THE CASE.

3.2.5.7 SALT SPRAY

THE COUPLER WILL NOT BE AFFECTED BY EXPOSURE TO SALT SATURATED WATER VAPOR. PERIODIC MAINTENANCE IS REQUIRED TO CLEAN THE ANTENNA INSULATOR, AND PAINT THE MOUNTING SURFACES AND CLEAN GROUND CONNECTION.

3.2.6 TRANSPORTATION

N/A

3.3 DESIGN AND CONSTRUCTION

3.3.1 MATERIALS, PROCESSES, AND PARTS

ROCKWELL INTERNATIONAL CORPORATION
COLLINS GROUPS
DALLAS, TEX 75207 NEWPORT BEACH, CALIF 92663 CEDAR RAPIDS, IA 52408

PREP G. SNIDER	SIZE A	FSCM 13499	DWG NO. 670-3022	REV LTR —
CHK J MORGAN	SCALE NONE		SHEET 10	

3.3.1.1 MATERIALS AND PROCESSES

SELECTION OF MATERIALS AND PROCESSES SHALL BE MADE FROM ROCKWELL INTERNATIONAL, COLLINS DIVISION, PREFERRED MATERIALS AND PROCESSES MANUAL 523-0764-441.

3.3.1.2 PARTS

SELECTION OF COMMERCIAL COMPONENT PARTS SHALL BE MADE FROM ROCKWELL INTERNATIONAL, COLLINS DIVISION, PREFERRED STANDARD PARTS LIST (PSPL) 523-0759-260, PARTS WITH SINGLE SOURCE VENDORS BEING AVOIDED WHEN POSSIBLE. THE UNIT SHALL BE DESIGNED SO THAT PART APPLICATIONS INCORPORATE DERATING TO THE MAXIMUM PRACTICAL EXTENT, IN ACCORDANCE WITH DERATING GUIDELINES PROVIDED BY RELIABILITY ENGINEERING.

3.3.2 ELECTROMAGNETIC RADIATION

DESIGNED IN CONSIDERATION OF THE TESTS IN ACCORDANCE WITH MIL-STD-461:

- A) MIL-STD-461 (CE01) POWER LEADS, CONDUCTED EMISSIONS 30 HZ TO 20 KHZ.
- B) MIL-STD-461 (CS01) POWER LEADS, CONDUCTED SUSCEPTIBILITY 20 HZ TO 50 KHZ.
- C) MIL-STD-461 (CS02) POWER LEADS, CONDUCTED SUSCEPTIBILITY 50 HZ TO 50 MHZ.
- D) MIL-STD-461 (CS03) POWER LEADS, CONDUCTED SUSCEPTIBILITY, SPIKE.
- E) MIL-STD-461 (RSC2) RADIATED SUSCEPTIBILITY, MAGNETIC INDUCTION FIELDS.
- F) MIL-STD-461 (RS03) RADIATED SUSCEPTIBILITY, 14 KHZ TO 10 GHZ, ELECTRIC FIELD.

**ROCKWELL INTERNATIONAL CORPORATION
COLLINS GROUPS**

DALLAS, TEX 75207 NEWPORT BEACH, CALIF 92663 CEDAR RAPIDS, IA 52408

PREP	G. SNIDER	SIZE	FSCM	DWG NO.	REV
		A	13499	670-3022	LTR —
CHK		SCALE		SHEET	11

introduction

DESIGN FEATURES

- The HF-8040 and HF-8040M Antenna Couplers are designed to automatically match the impedance of various whip and long-wire antennas to the output impedance of a 1-kW power amplifier.
- The HF-8040 Antenna Coupler consists of a chassis assembly with plug-in modules for ease of replace-

ment. The aluminum case is provided with a self-sealing cover that is secured by twist-lock fasteners for fast removal. An internally mounted fan is provided for cooling of the components.

- The HF-8040M Antenna Coupler is similar to the HF-8040 Antenna Coupler. Refer to the HF-8040M Antenna Coupler Supplement, 523-0771398, in this instruction book for information on the HF-8040M.

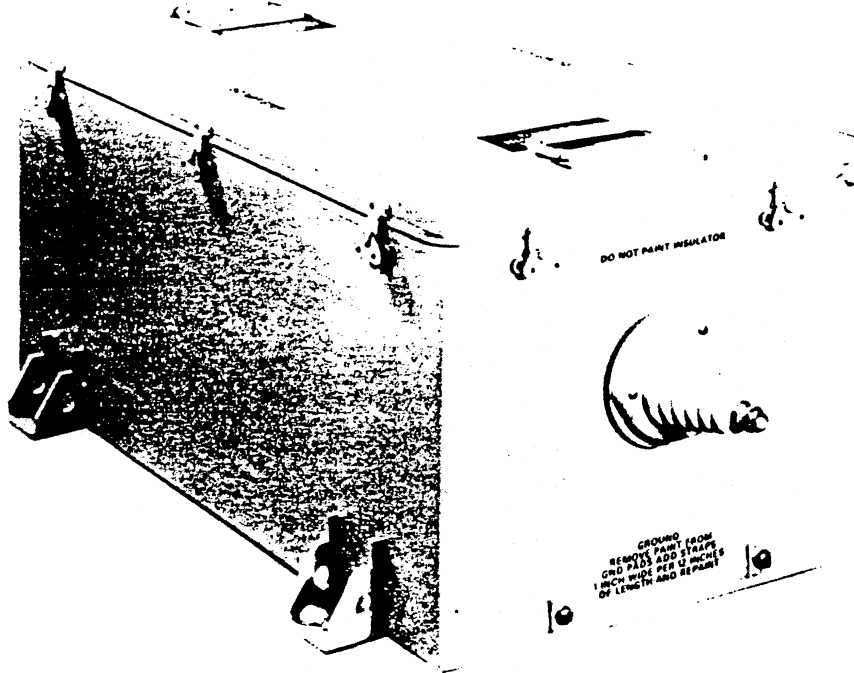

TP5-1892-017

HF-8040 Antenna Coupler

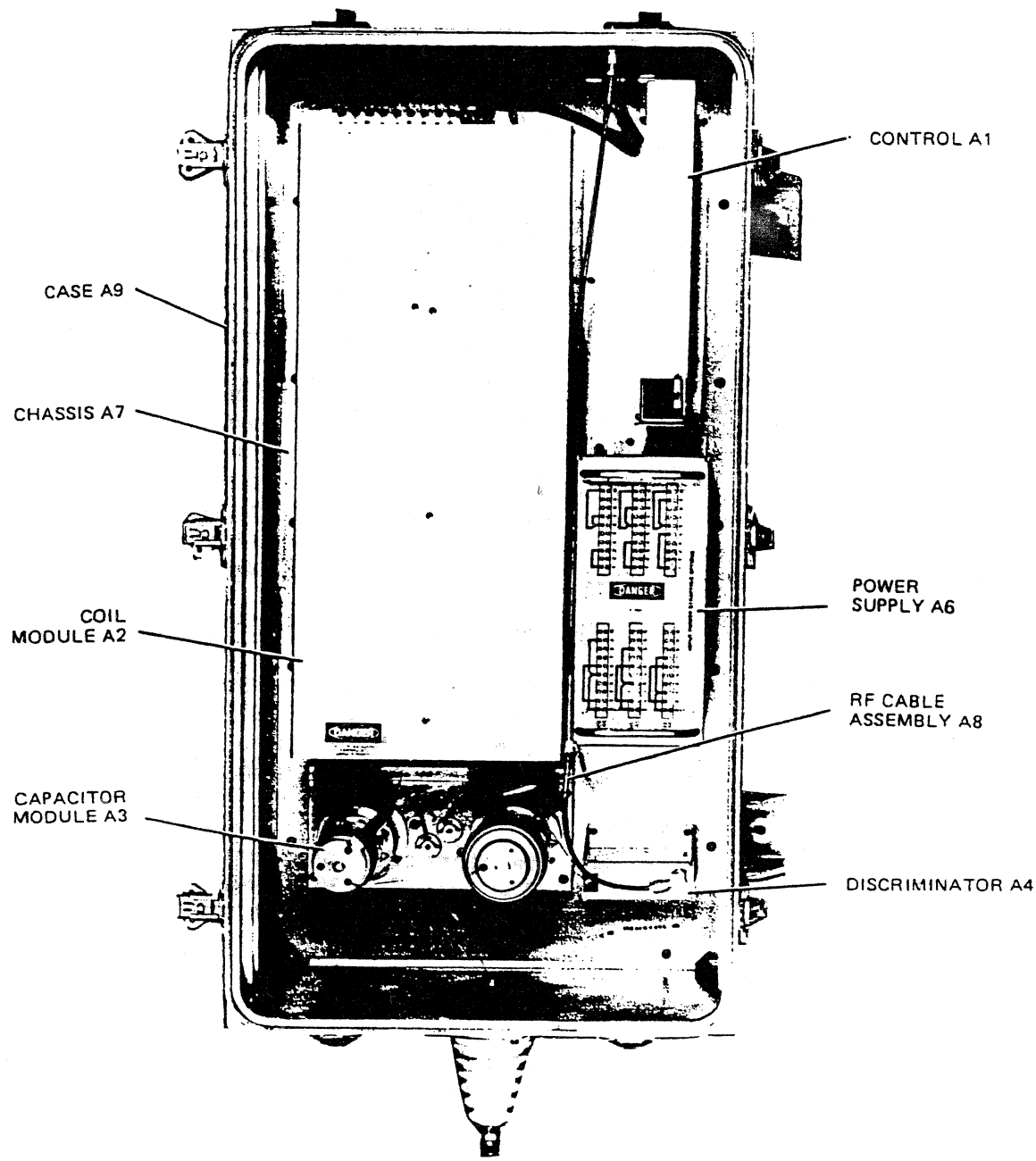

TP5-1893-017

Subassembly Location
Figure 1

4. Distribution the radials around the coupler connect each solder lug to one of the six coupler mounting screws.
5. For ground-mounted installations, bend each radial 90 degrees downward approximately 75 mm (3 in) from free end and push end into ground.
6. If required, bury radials no deeper than 152 mm (6 in) below surface of soil.
7. For roof-mounted installations, use nails or other fasteners to secure radials in place.

Installation of the Antenna Coupler

- a. Secure the antenna coupler to a suitable mounting surface using four 6.35-mm (0.25 in) bolts.
- b. Ground the case of the antenna coupler with a suitable ground strap. (A ground strap must be at least 25.4 mm (1-in) wide for each (foot) of length required between the antenna coupler and the antenna ground radial system.) Grounding may be accomplished by mounting the antenna coupler on a metal surface and making electrical contact to the top of the mounting feet (or ground bosses). The ground connection must be inspected and cleaned periodically if evidence of corrosion is present.

Caution

The HF-8040 is internally connected for 244-V ac operation when shipped. Strap the power transformer of the antenna coupler in accordance with paragraph 3.2.2 or 3.2.3.

- c. Refer to the system interconnection diagrams for the HF-8031/8130A, HF-8134/8134A, or HF-8135/8135A in paragraph 4 of their respective instruction books. Connect the antenna, rf input, and control cables to the antenna coupler.

Note

Verify that the 10 twist-lock fasteners on the cover and the pressure relief valve are securely tightened to assure watertightness

HF-8040 and HF-8040M Antenna Couplers

Figure 18 shows the outline and mounting dimensions of the HF-8040 Antenna Coupler and figure 19 shows the outline and mounting dimensions of the HF-8040M. Refer to figure 20 for typical installation information for the HF-8040.

Warning

The HF-8040 weighs about 35.5 kg (78 lb) and the HF-8040M weighs about 40.8 kg (90 lb). Use heavy equipment handling aids to avoid injury to installation personnel.

Installation of Ground Radials

- a. For optimum performance, the following conditions should be met while installing ground radials:
 1. Transmitting on multiple frequencies requires the radials to be cut to lengths determined by the lowest frequency of operation.
 2. A minimum of eight radials per installation is recommended.
 3. Ground radials for one installation should not overlap any ground radials from another installation.
- b. Perform the following procedure for assembly and installation of ground radials.
 1. Cut antenna radials to length according to desired frequency selected by this formula:

Antenna Radial length

$$= \frac{81.3}{\text{Freq (In MHz)}} \text{ metres}$$

or

$$= \frac{234}{\text{Freq (In MHz)}} \text{ feet}$$

2. Solder a solder lug to one end of each length.
3. Lay out radials evenly to resemble spokes of a wheel with solder lug end at center.

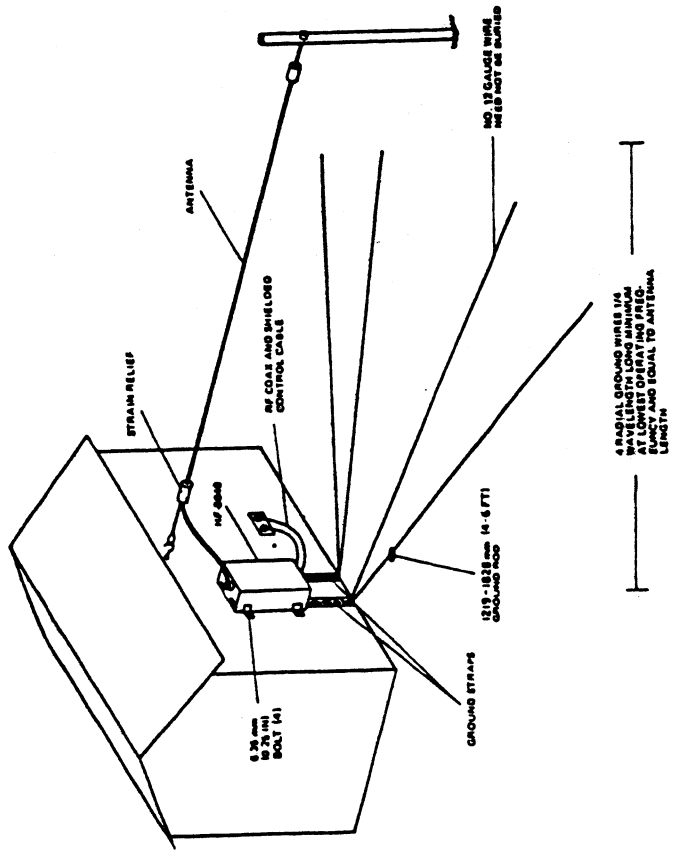

TYPICAL INSTALLATION WITH LONG-WIRE ANTENNA

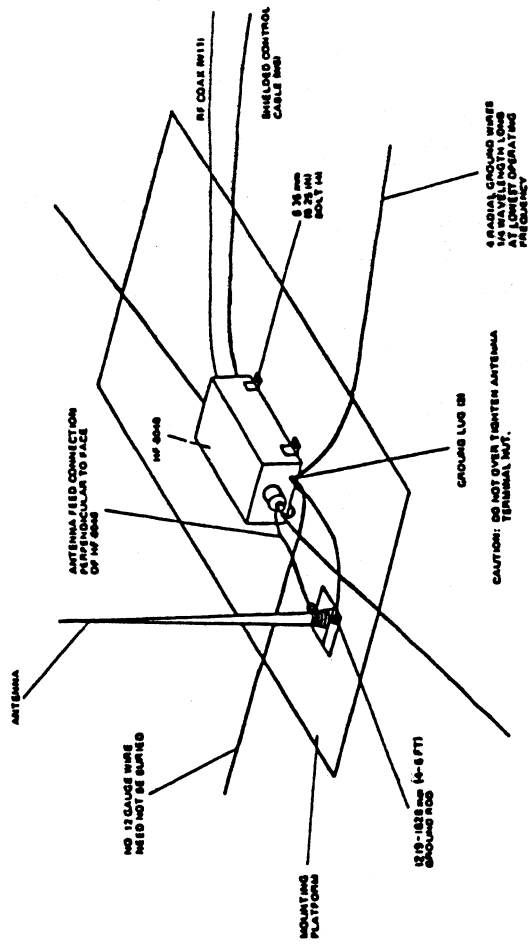

TYPICAL INSTALLATION WITH WHIP ANTENNA

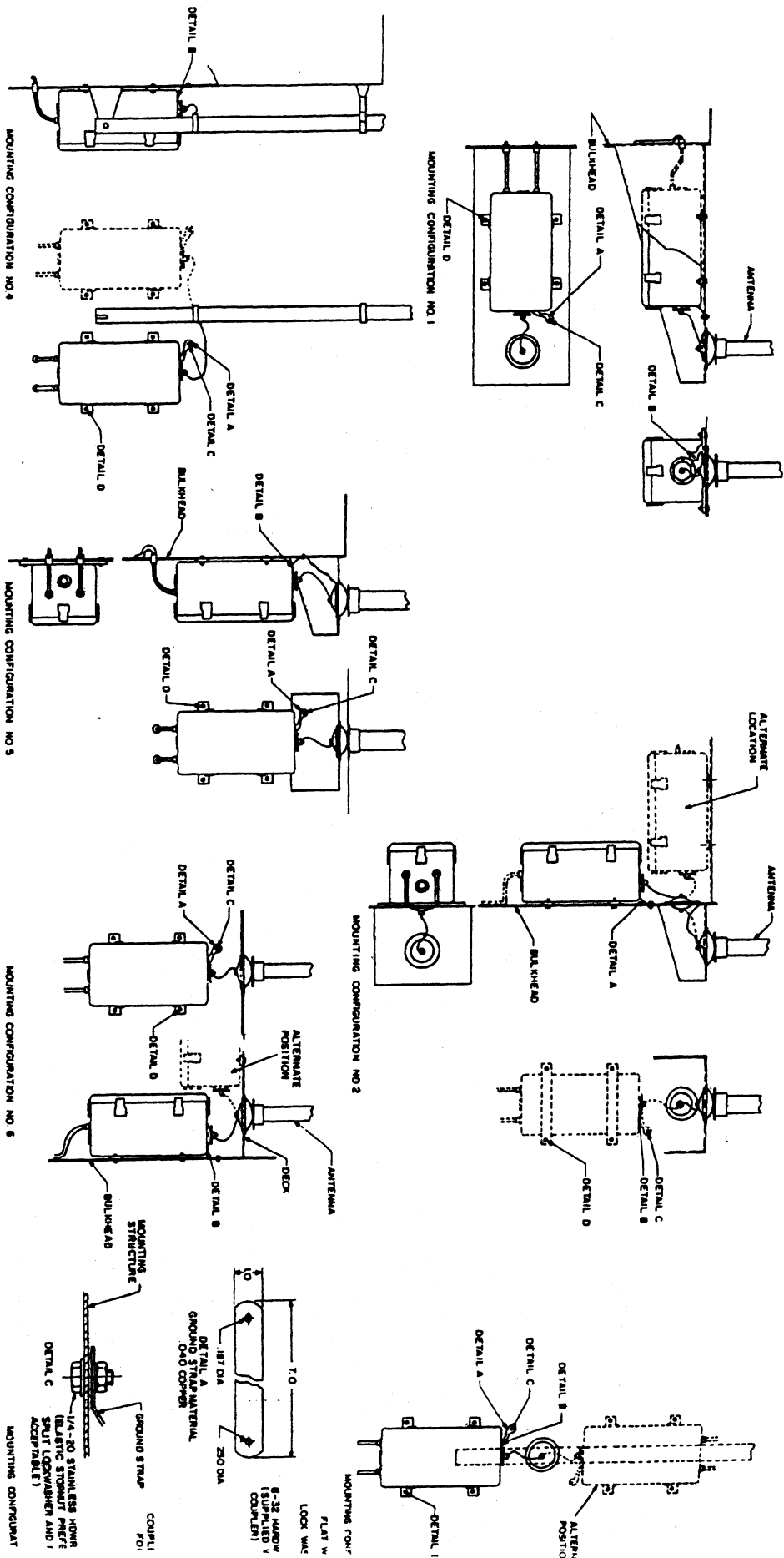

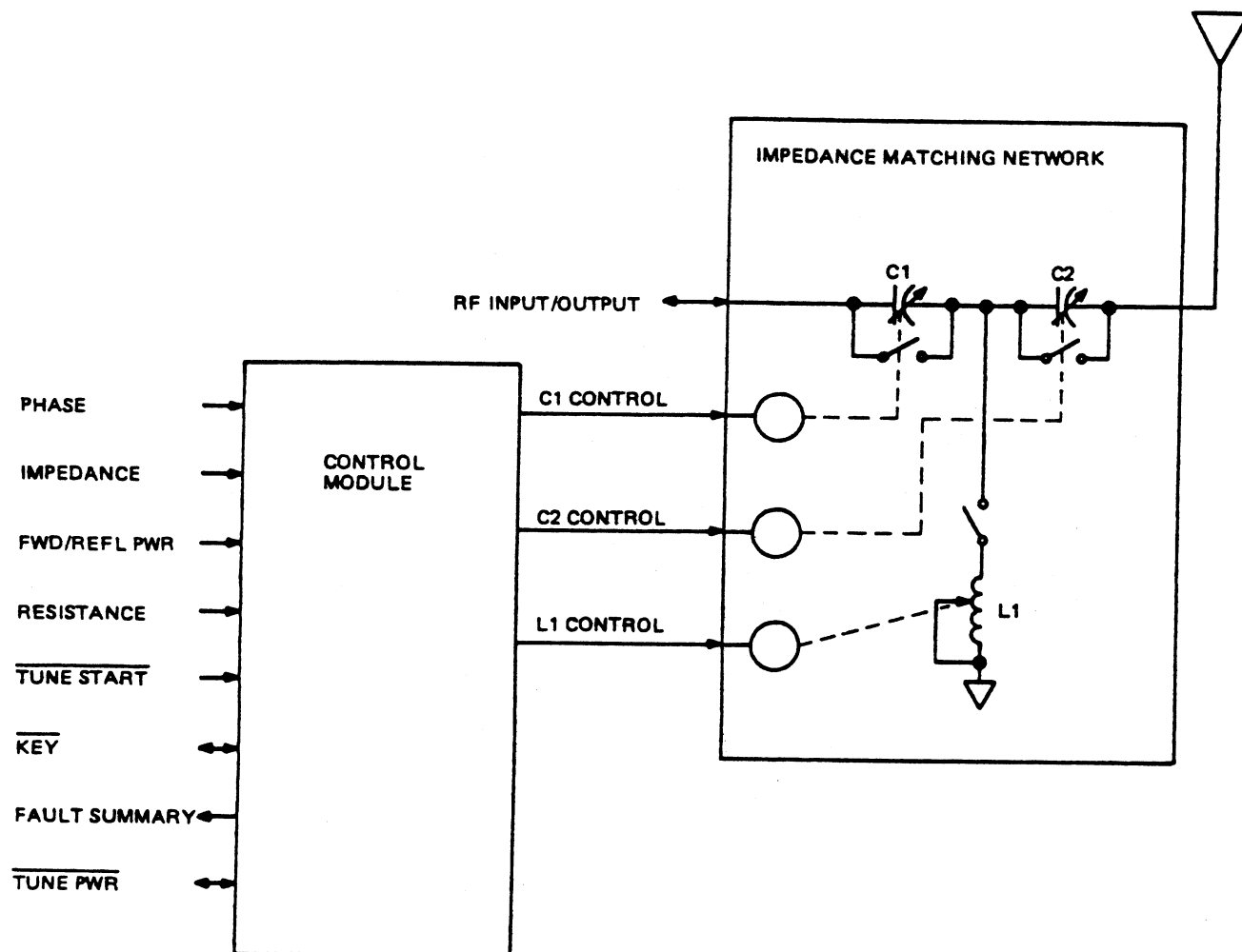

TP5-0949-011

Tune Sequence, Functional Block Diagram
Figure 2

verts these signals (phase, impedance, forward/reflected power, and resistance) to tuning drive signals that tune an impedance matching network. The tuning of the impedance matching components (C1, C2, and L1) are accomplished in a specific sequence. The six steps of the tuning sequence are as follows: home, receive/standby, tune A, tune B, tune C, and operate.

2.2 Functional Theory of Operation

Refer to figure 3 (block diagram) and figure 6 (schematic diagram) during the following discussion of the control module.

2.2.1 Timing and Enabling Circuits

The clock oscillator produces a square-wave output that is used as a master 10-millisecond time refer-

ence for the tune sequence counter and the delay circuits. The advance summary circuit provides an output signal when the tune logic circuits have completed a specific tune step. This output signal is routed through a 100-millisecond delay circuit and enables the tune sequence counter. The tune sequence counter then advances to the appropriate tuning step.

2.2.2 Fault Latch Circuit

The fault latch circuit receives a set input from the 6-second delay circuit if the home, tune A, tune B, or tune C step requires more than 6 seconds to complete. A set input is also applied when the high-voltage sample from the antenna exceeds a safe level. When a set input is received, the fault latch circuit

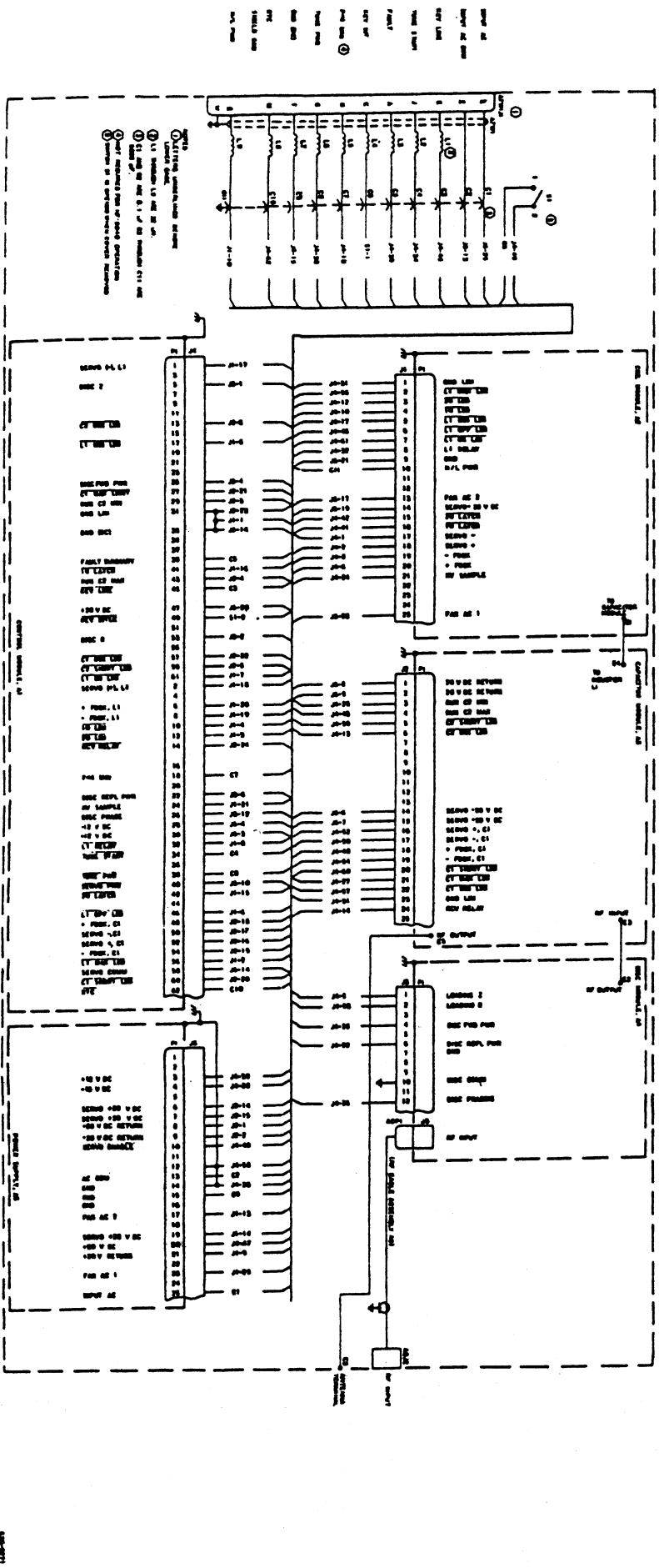

Wiring Diagram of Aircraft System

- d. Connect the antenna feedline to the antenna terminal on the antenna coupler.
- e. Tighten the 10 quick-release fasteners on the antenna coupler to ensure watertight integrity.

Caution.

The pressure relief valve must be closed to ensure proper sealing.

- f. Tighten the pressure relief valve.

5. POSTINSTALLATION CHECK/ REQUIREMENTS

After the antenna coupler has been installed and all cabling has been checked for proper installation, refer to the maintenance section of the appropriate system instruction book for testing.

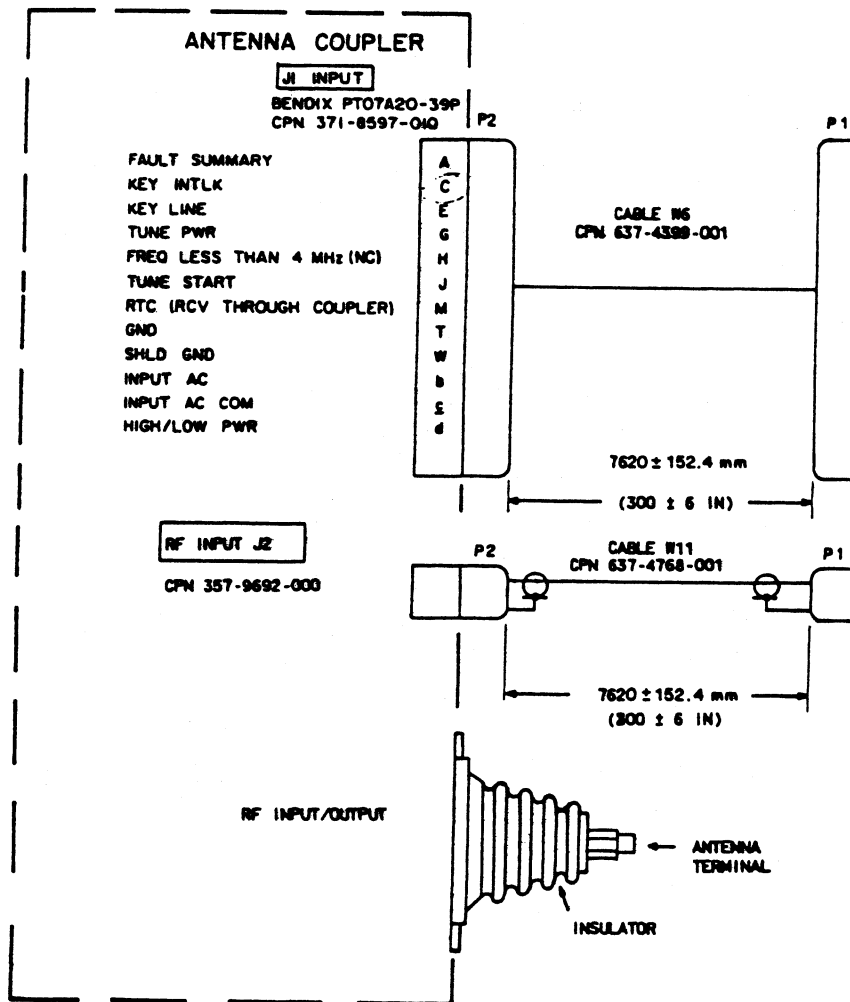

TP5-0433-013

External Wiring Diagram
 Figure 1

HF-8030 to HF-8040 CABLE W6 INTERCONNECTIONS

<u>HF-8030 Description</u>	<u>HF-8030</u>	<u>HF-8040</u>	<u>HF-8040 Description</u>
115/230 VAC Switched	J5-1	P1-B	115/230 VAC Switched - applied through the low voltage enabling circuits of the power supply the primary power for the coupler. Internal strapping accomodates either voltage.
115/230 VAC Switched	J5-9	P1-C	
Shield Ground	J5-2	P1-W	Shield, Ground
Not used, spare	J5-3	P1-D	Spare
Spare	J5-4	-	Not used
Spare	J5-11	P1-F	Spare
<u>Ant Intlk (Coupler)</u>	J5-5	P1-C	Antenna interlock (coupler) A logic 0 developed in the coupler when ready to accept RF power applied through the power supply to the power amplifier.
<u>System Key</u>	J5-6	P1-E	System key - a logic 0 from the receiver/exciter through the power supply causes the RF timing elements to be in transmit and IF in home, to start new tune cycle.
Coupler Fault	J5-7	P1-A	Antenna coupler fault - a logic 1 developed in the antenna coupler and applied through the power supply to the receiver/exciter coupler fault lamp with excessive tuning time or excessive voltage applied to the antenna terminal.
<u>System Tune Start</u>	J5-8	P1-D	System low power enable - a logic 0 developed in the antenna coupler and applied through the power supply to the pwoer amplifier when internal temperatures are excessive to enable the low power circuits.
<u>Low Level Ground</u>	J5-10	P1-T	Low Level Ground
<u>Coupler Tune Power</u>	J5-12	P1-G	Tune power - a logic 0 developed in the antenna coupler, when not tuned, applied through the power supply to the power amplifier to limit RF power to nominally 200 watts while tuning.
Freq < 4 MHZ	J5-13	P1-H	Freq < 4 MHZ - not used with this antenna coupler.
Shield Ground	J5-2	P1-M	Receive through coupler - not used in this system.
System Tune Start	J1-15	P1-J	System tune start - a logic 0 developed in the receiver/exciter and applied through the power supply when a transmit frequency change is made, causes the RF timing elements to home.

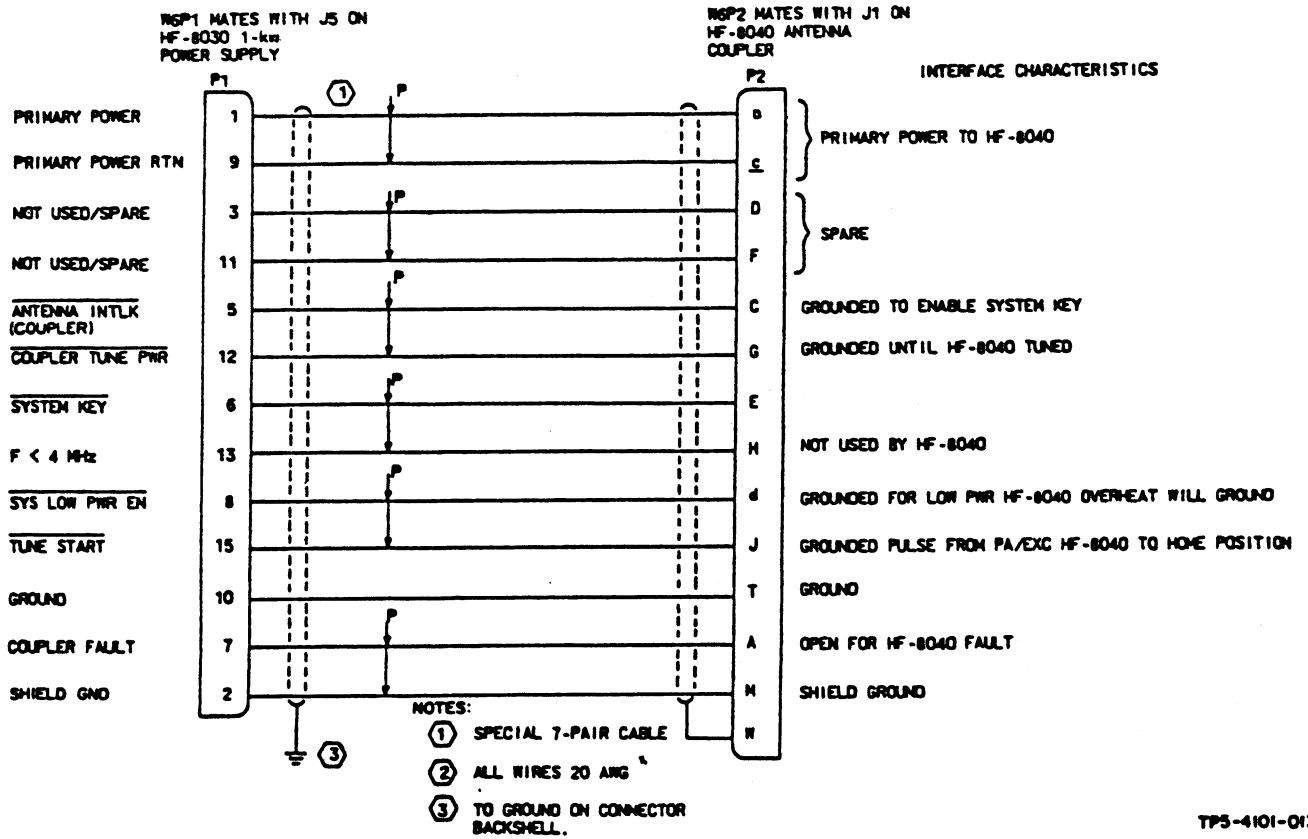

Cable W6, Wiring Diagram
Figure 4

HF-8040 Controller Box

